



CITY OF INDUSTRY, CA  
BROOKSHIRE, TX  
BOLINGBROOK, IL  
JERSEY CITY, NJ  
POOLER, GA  
CONTACT US  
SALES: 447-902-3857  
TECHNICAL: 716-299-8852  
EMAIL: INFO@AUTOKATO.COM

# WL-70

## RIM STRAIGHTENER



Read the entire contents of this manual before using this product. Failure to follow the instructions and safety precautions in this manual can result in serious injury or death. Make sure all other operators also read this manual. By proceeding with setup and operation, you agree that you fully understand the contents of this manual and assume full responsibility for product use.

***Please follow the instructions to use***

## ***The machine***

---

**KEEP THE MANUAL NEAR THE MACHINE ALL TIME AND  
MAKE SURE ALL USERS HAVE READ THIS**

**FOLLOW THE INSTRUCTIONS CAREFULLY TO GRANT  
THE MACHINE A CORRECT FUNCTION AND**

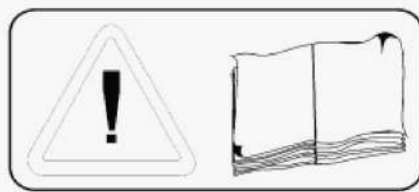

## ***Rim Straightening Machine***

---

***\*Manufacturer keeps the rights to improve the contents in this manual***

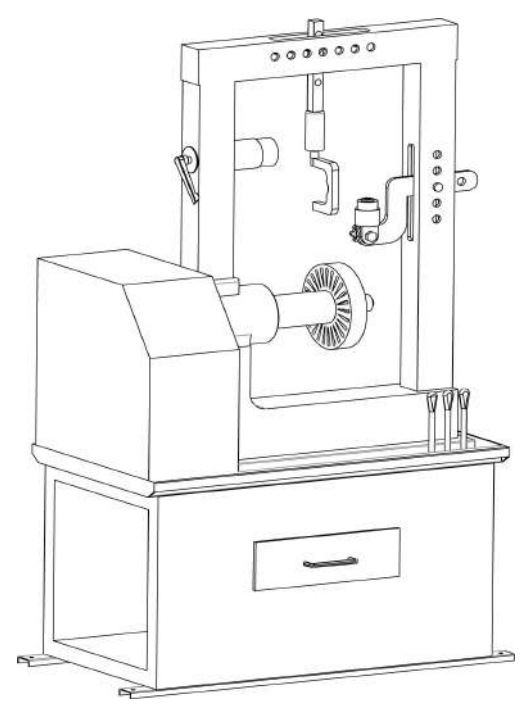
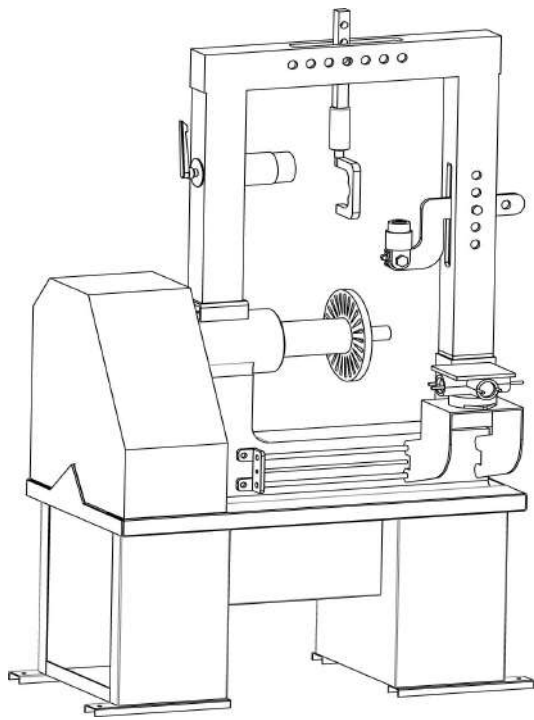

## **Notice**

The manual is a main part of the product. Before using the machine, please carefully study the warnings and instructions mentioned in it, It is important for safe use and maintenance.

Note: This machine is a rim press to repair the defective rims.

The machine must be used only by the functions for which it was expressly designed, Any other use is considered wrong and unacceptable.

## **IMPORTANT**

This machine must be operated only by the trained personnel, Any work on the electrical, hydraulic, pneumatic systems must be conducted only by professionally qualified personnel.

## **CONTENT**

1. General notice .....	2
2. Technical characteristics.....	2
3. Parts of the machine .....	3
4. Packing, lifting and transport .....	4
5. Machine description.....	3
6. Introduction .....	4
7. Safe warnings .....	5
8. Base cross sliding table.....	6
9. Problems, causes and remedies .....	6
10. Operations and use .....	8.9
11. Latern mile montage .....	10
12. Daily maintenance .....	11
13. Technical assistance and spare parts.....	11
14. Electrical layout .....	11

### **Technical Characteristics**

#### **Specification**

height..... 1390mm

length..... 1400mm

width..... 900mm

#### **Weight**

Net weight..... 330kg

noisy..... 75db

## Machine Description

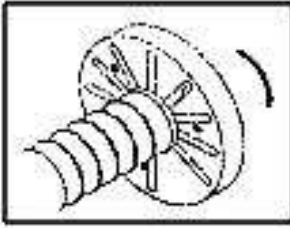

- The flange must rotate in arrow direction

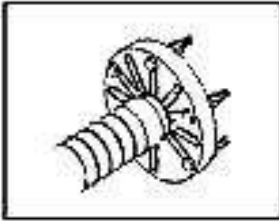

- Rim connecting flange  
The flange is designed to serve different size rims

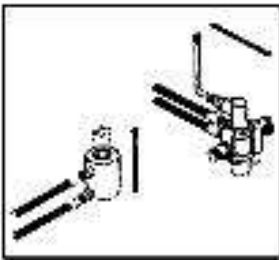

- Controlling unit  
This part is to control the movements of piston.

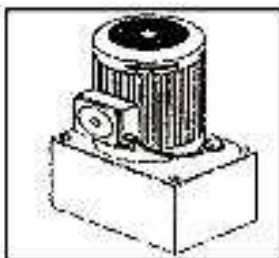

- Hydraulic unit  
This part can move the piston up and down.

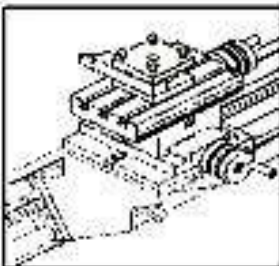

- Lathe unit  
This part is to lathe the defective rims after repairing

## **Instruction**

This manual has been prepared for workshop personnel expert in the use of machine and technicians who are responsible for routine maintenance; Read the manual before starting any operation with the rim repairing and packing. This manual includes important information concerning:

- The safety of rim repairing machines
- Personnel safety of operations and maintenance workers.

### **Packing, Transport, Storage**

The pallets must be moved with a lift truck, the equipment chosen must be suitable for safe lifting and moving Bearing in mind the dimensions, weight and fragile pares not to be damaged.

### **Storage**

Packed machinery must always be kept in a covered, protected place at a temperature between -10°C to +40°C and must not be exposed to sunlight directly.

### **Packages Stacking**

The type of packing allows the possibility of stacking up to 2 packages, provided they are restrained to Prevent falling, Up to 2 pallets may be stacked one upon the other on truck or in containers if properly positioned and provided they are restrained to prevent falling.

### **Opening crates**

When the crates arrive, check that the machine has not been damaged boring transport and that all the listed parts are present. The crates must be opened using all possible precautionary measures to avoid damaging the machine the machine or its parts. Make sure that parts do not from the crate during opening.

### **Disposal of crates**

The wooden pallets and the packing film may be re-cycled.

## **Safety**

- This machine is designed only for 10 " -22.5 " rims.
- This machine must be used only for rim repairing operation
- Pay attention to the warning signs on the machine

If the operator hears unusual noises or vibrations or something that may be dangerous, he must immediately button main switch off the main switch and check the section "Causers and possible remedies" in the instructions manual. if the problem is still, please call the service.

- Wearing protection glasses and gloves during operation
- Stand straight during operation

**Lighting:** All parts of the machine must be uniformly lit with sufficient light to assure that the adjustment areas of shadow, reflected light, glare and avoiding all situations that could give rise to eye fatigue.

- Work in an insulated and clean area
- Switch off the main switch when there is no electricity.
- Work in the safe distance
- The machine must be fixed onto smooth place.

**!DO NOT STAND IN FRONT OF THE FLANGE WHEN IT IS RUNING**

## Safety

- Do not put your hands between the piston and be sure that the rim is well fixed to the flange.
- Do not use the piston on living things

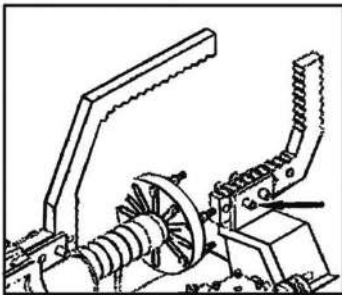

- Be sure that the support pins are mounted and Check that the piston is in canal.

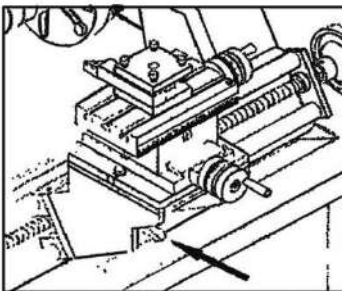

- Tight the fixing handle during lathe operation.
- Do not use the jets of water, steam (high pressure wash units), solvents near the rim repairing machine.
- Unplug or switch off the main switch before starting cleaning the machine.

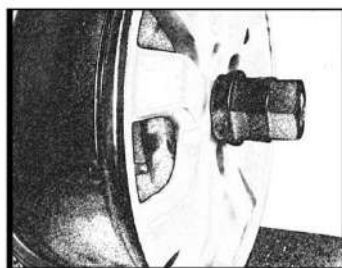

- Lock nut



- Speed adjustable

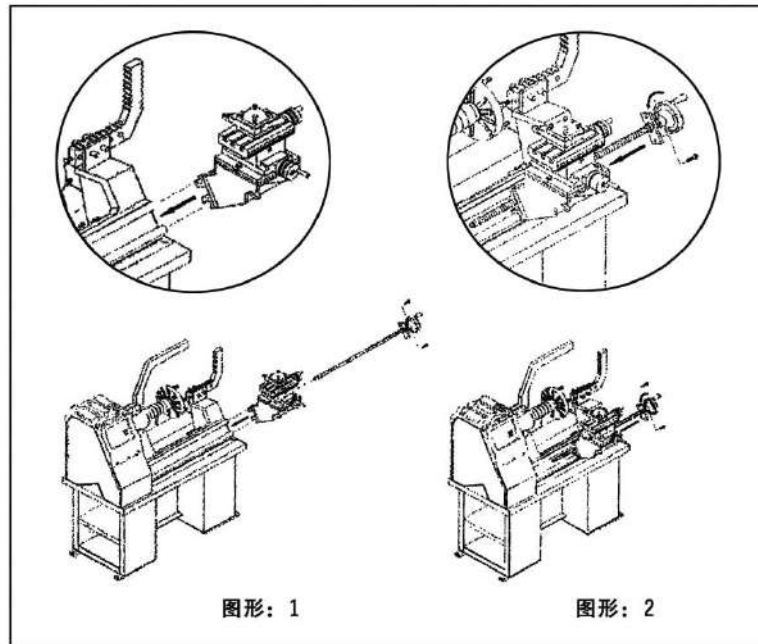

Figure 1: Montage the base cross sliding table to the body by the sliding rows.

Figure 2: Screw the handle to the sliding table and tight back connecting lama to the sliding miles.

### Problems-Causes-Remedies

<p>The flange does not rotate in any direction.</p>	<ol style="list-style-type: none"> <li>1. The main connection is not plugged in.</li> <li>2. Faulty fuse. The plug is not correctly wired.</li> <li>3. The main switch is not on</li> </ol>	<ol style="list-style-type: none"> <li>1. Check the correct insertion of the plug and its connection.</li> <li>2. Switch on the mains.</li> <li>3. Replace the fuse.</li> </ol>
<p>The pressure of the hydraulic unit is not enough.</p>	<ol style="list-style-type: none"> <li>1. The rotation of the hydraulic engine is reverse,</li> <li>2. There is leak of oil in the connection.</li> <li>3. There is leak of oil in the hydraulic engine.</li> </ol>	<ol style="list-style-type: none"> <li>1. Reverse the two wires in the connection plug.</li> <li>2. Check the couplings, change them if necessary</li> <li>3. Filing oil to the hydraulic engine.</li> </ol>

## **To fix the machine on the floor**

- In order to have a good functioning, the machine must be fixed onto the floor with expansion dowels.
- a. Drill the floor with a helical concrete bit with a diameter of 15mm, using the holes in the 2. base as a drilling template.
- b. Move the rim repair and insert anchor bolts into the drills, then set the machine in the place to be fixed.
- c. Insert into the anchor bolts and use a torque wrench ( setting of 25N/m ) to tighten.

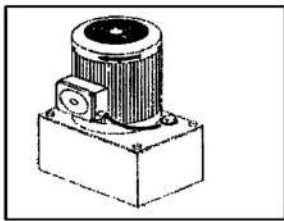
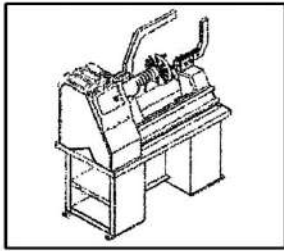

### **Location**

#### **Safe distance:**

For the safe and ergonomic use of the machine, it is advisable to locate it in order to allow work in conditions of complete safety.

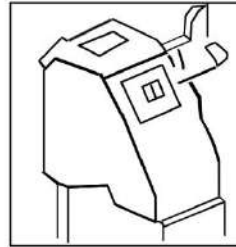

ALL WORK ON THE ELECTRICAL SYSTEM, INCLUDING MINOR OPERATIONS MUST BE CARRIED OUT BY PROFESSIONALLY QUALIFIED PERSONNEL

- Check that the main supply is same as that shown on the registration plate.
- Connecting the cable to plug that confirms with European norms or to the norm of the country in which the machine used.
- The plug must have an earth terminal.
- Check that the earth connection is effective.
- The machine must be connected to the mains through a multiple isolating switch which confirms with European norm and with contact openings of at least 3mm.
- Check that multiple connector on the electrical board is correctly connected.
- When the machine is connected, switch it on and check the correct direction of rotation; this should be as shown by the arrow on the motor unit.
- If the rotation is reversed, reserve the two wires in the connection plug.
- If the machine operates abnormally, immediately press the emergency button and switch off the main switch and check the section of "Causes and possible remedies" in the instruction manual.

THE MANUFACTURER DOES NOT ACCEPT ANY RESPONSIBILITY FOR THE FAILURE TO OBSERVE THE ABOVE MENTIONED INSTRUCTIONS

## Operations and Use

### •Connecting to the defective rim to the flansh

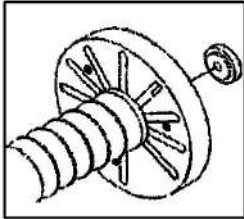

1. Clean the mud and the balance weights from the rim
2. Choose a suitable sized connecting flange for the rim.

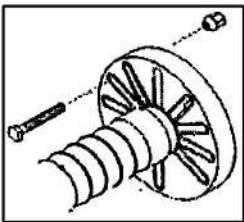

3. Tight the nuts to start repairing
4. Tight the connecting flange and fasten to the suitable canals on the flanges.

### •Analysing the defective area

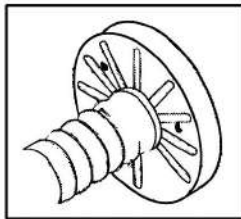

1. Rotate the flange.
2. Locate the defective area by using gauge and mark it.

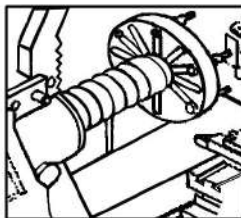

3. Tight the nuts to start repairing
4. Choose a suitable support and repair it.

### •Rim repairing positions

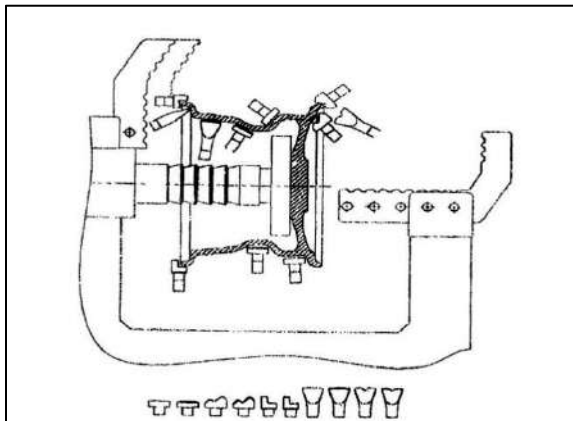

## Operation and Use

Some examples of repairing

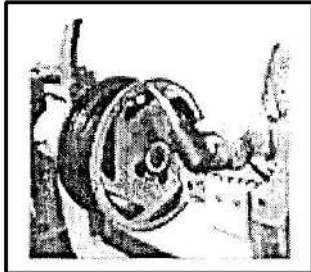

- If the defect is on the front surface to the outer side of rim.  
If the defect is from inner to outer side of rim.

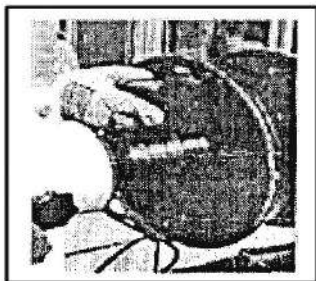

- If the defect is from outer to inner side of rim.

### Operation and Use

When repairing iron rims use also the manual handle plus to the pressing.

Before the pressing operation, some rims need to be heated (especially aluminum rims) This procedure is for:

1. Avoiding cracks and faults on the rim,
2. Piston's safety.
3. Your personnel safety

If the rim is defected much, first mend it with the lever and then it with pressing.

### Lathe Operation

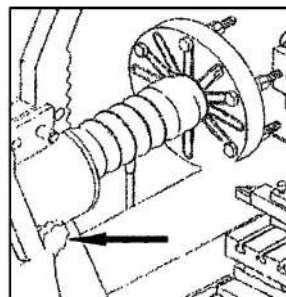
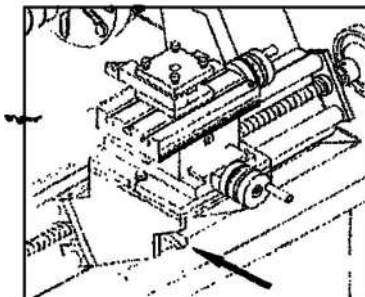

Tight the fixing handle during lathe operation Untight the nuts durinf la the operation

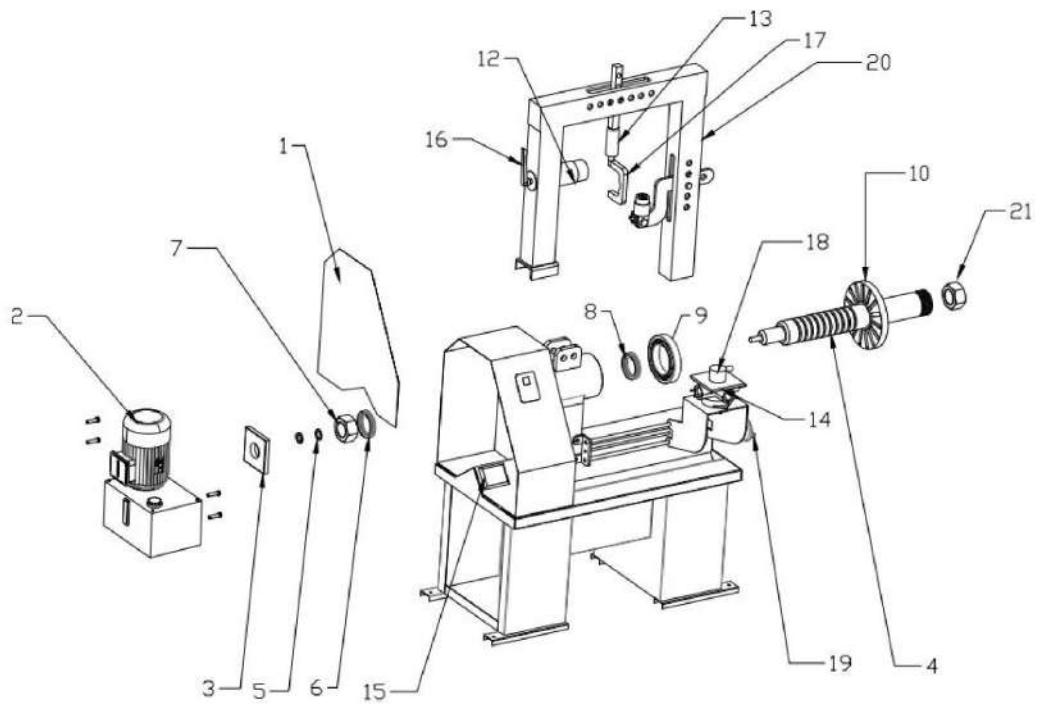

- |                     |                   |
|---------------------|-------------------|
| 1 partition         | 11 cylinder       |
| 2 hydraulic pump    | 12 cylinder       |
| 3 spindle partition | 13 cylinder       |
| 4 spindle           | 14 lathe          |
| 5 gasket            | 15 inverter       |
| 6 bearing(32016)    | 16 locknut        |
| 7 nut               | 17 tension wrench |
| 8 bearing(32016)    | 18 lathetool      |
| 9 bearing partition | 19 handwheel      |
| 10 turntable        | 20 gantry         |
|                     | 21 nut            |

## Daily Maintenance

To guarantee the efficiency of the machine and for its correct functioning is essential to carry out the routine cleaning and maintenance.  
Routine maintenance must be carried out by the user according to the maker's instruction. Before starting any cleaning or maintenance, switch off the main switch and remove the main plug from socket.  
Every day  
Clean and grease the flange and lathe  
Every month  
Check the oil level of the hydraulic unit.  
Every 6 months  
Grease the bearings and make a general check  
Every year  
General check: Visual inspection of all structural parts and mechanisms to guarantee that there are no problems.  
Electric plant. Skilled electricians should test the electric plant.

## Storage

Periods of in activity	Permanent Storage
The machine is temporarily stored or Whenever the machine is not in use, Remove the plug from the mains	If it is decided to store the machine longterm, It is advisable to make it inoperative by removing the mains cable after having unplugged it from the mains.

### TECHNICAL ASSISTANCE AND SPARE PARTS

- The machine is guaranteed ( 1 years ); The relevant certificate of guarantee is supplied with the machine.
- For any machine of functions, consult the section \*Causes and Possible Remedies Any other functions must be checked by professional qualified personnel.
- In all cases contact the assistance service of Xi'an Sedi. For prompt assistance it is important at the time of call to specify the machine model, the production No. (pls find it on the registration plate) and type of trouble.

### WARNING

Any work on the electrical, hydraulic and pneumatic systems must be carried out only by PROFESSIONALLY QUALIFIED PERSONNEL.



The motors are not under guarantee.

### WARNINGS

Use only original parts of machine.

We do not take responsibility of non-original parts

## PARTS OF THE MACHINE

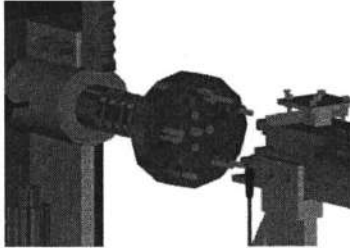

**RIM ATTACHING FLANGE**

Rim Flange is designed for different sizes and kinds of rims.

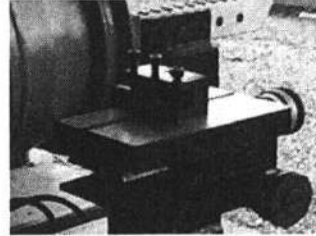

**LATHE UNIT**

Lathe unit is designed to correct defected rims.

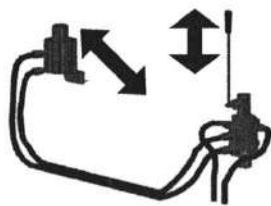

**PISTON CONTROL UNIT**

It enables us to control the piston.





**HYDRAULIC UNIT**

It enables us to push piston up and down.



### ***SAFETY***

- Piston should fit exactly onto rims and supports. Be sure that your clothes will not wrap around flanges. (ties, shirts cuffs, coat bottoms, etc.)
- Do not put your hands between rim and piston during operation.
- Fit the piston exactly onto supportive canals. If not it may slide and injure you.
- Do not direct the piston onto living creatures.
- Check that supportive pins are in their place.
- Fasten fixing nuts while levelling, loosen the nuts while lathing.
- Electrical and Hydraulic failures should be handled by experienced and competent technicians.

## **TECHNICAL SERVICE**

- In case of deflection or problems, see " HELP " section of this booklet.
- If you fail to solve the problem, contact technical service through "HOW TO CONTACT US " section.
- In order to solve your problem immediately please notify us serial number of the machine.
- This machine has 1 (one) YEAR-GUARANTEE,
- GUARANTEE covers all units without any exceptions.
- Hydraulic Unit should only be serviced by factory technicians.
- In hydraulic unit SHELL, TELLUS 27 type of oil should be used.
- Use original parts in your machine. Manufacturer has no responsibility for negative results of by-products.

### **ORDERING OF SPARE PARTS:**

- Call and inform us the model, serial number, production year of the machine.
  - Company name, address, and telephone numbers,
  - Code, name and quantity of required spare parts through " HOW TO CONTACT US" section.
- 

### **RIM STRAIGHTENING PROCESS**

- Clean soil on rim and remove leads.
- Select proper spangle for rim hole.
- Put the spangle onto the center of flange and fasten with nuts.
- Special nuts are designed for Renault rims, So use these nuts for Renault rims.
- Rim is attached by means of center spangles and rim revolves at c
- Select proper wrench for rim wrench hi
- Fasten the rim by using proper tools.
- Loosen nuts which fix flanges.
- Attach magnetic metal pointer (muven);
- Turn the rim by hand.

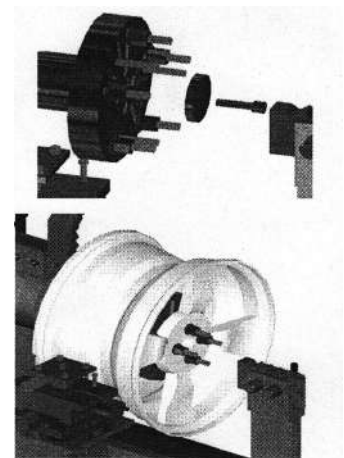

## RIM STRAIGHTENING PROCESS

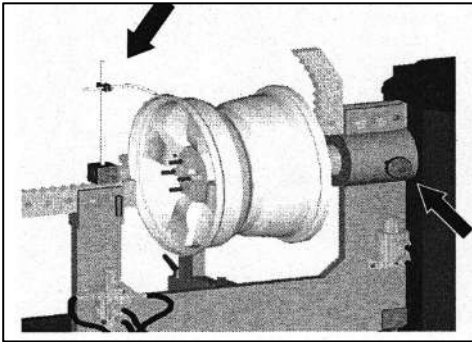

- Determine defected section and mark it by help of metal pointer.
- When you turn the rim onto the defected part where it is pressed, fasten flange fixing nut.
- Start hydraulic motor.

- Select proper press tip for the section to be straightened,
- After selecting support axis for the tips, place the selected axis/tip into the piston.

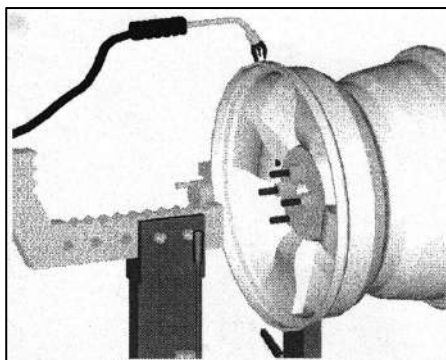
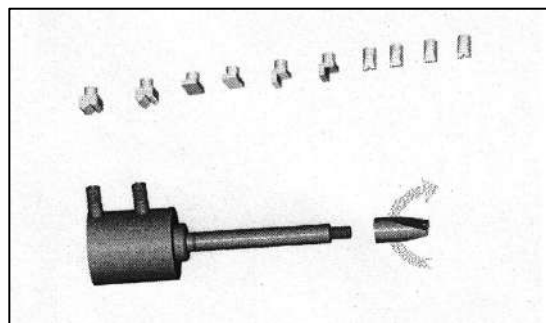

- Defected part is mildly heated with blow torch,.
- Heated defected part is corrected by applying pressure.
- After applying enough pressure, straightening is checked by metal pointer.
- Same process is applied until rim completely levelled.

- After this procedure continue lathing process if necessary.

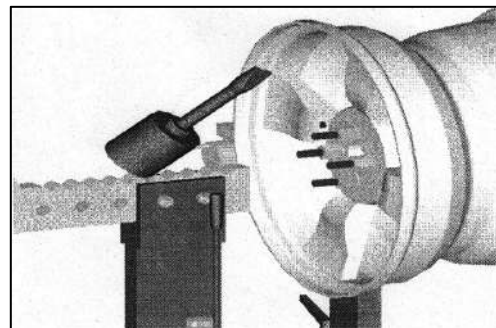

**PISTON and END POSITIONS .fRIM STRAIGHTENING**

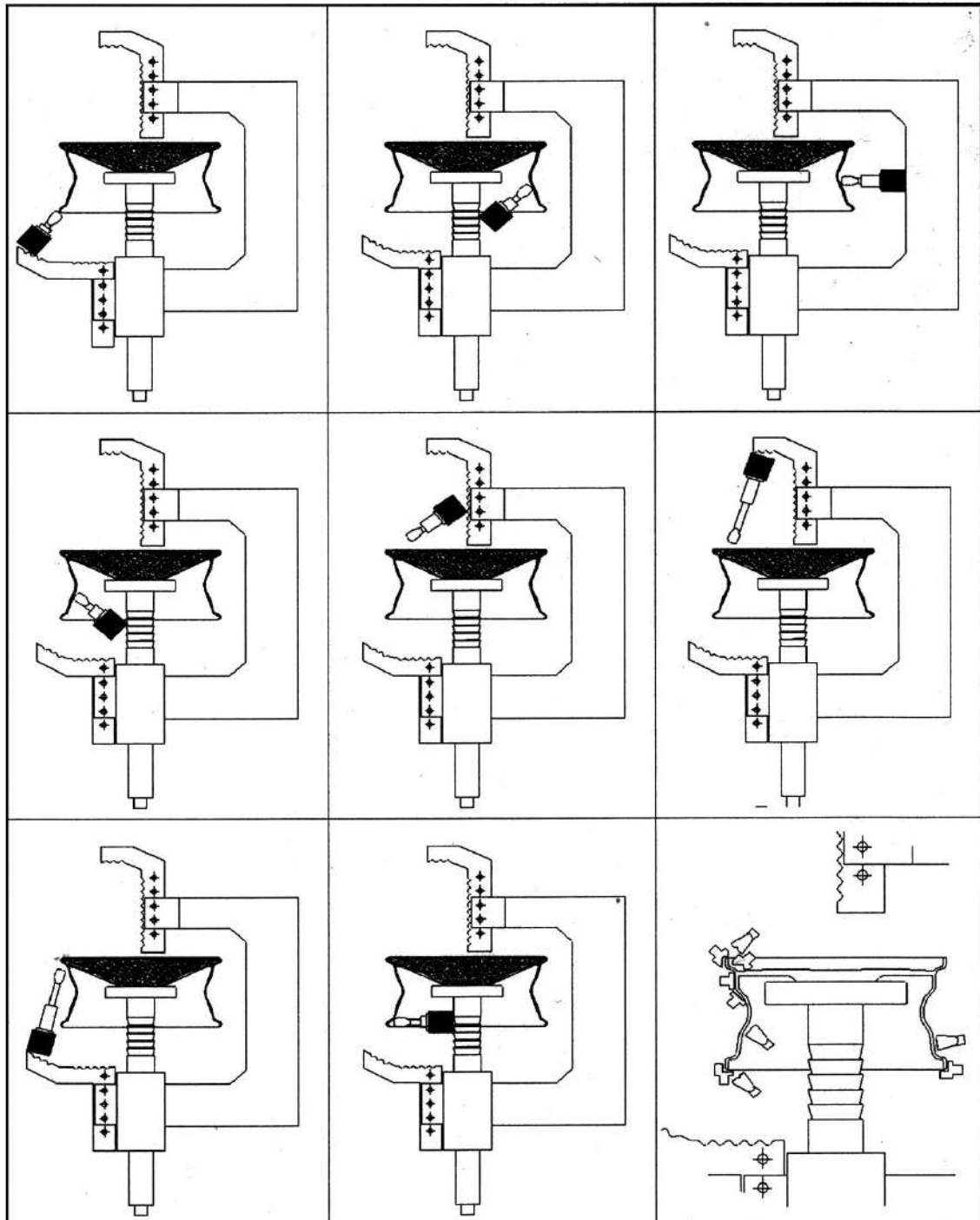

## RIM LATHING PROCESS

- Clean soil and dirt on the rim and remove leads.
- Select proper centering spangle for rim hole.
- At the center of flange, put centering spangle and fasten it with its nuts.
- Use special fixing nuts for Renault rims.
- By means of centering spangles, rim is fixed at flange and turns at its center.
- Select proper wrench for the holes of rim.
- Fasten the rim with proper wrench.
- Flange fixing nut is loosened.

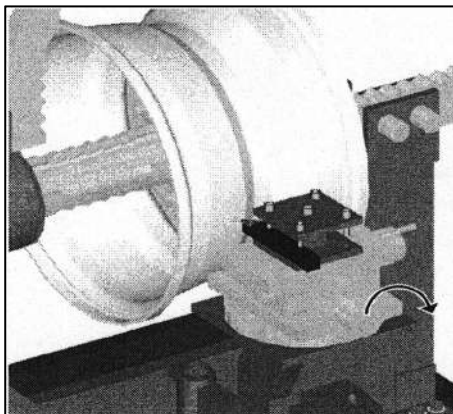
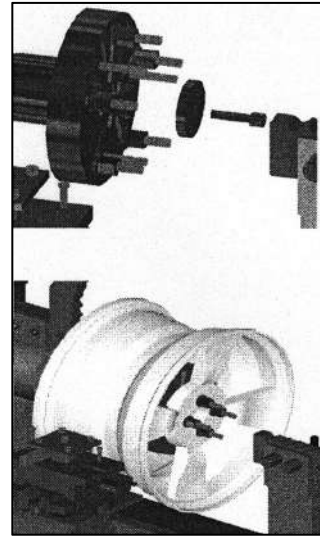

- Lathe base is positioned accordingly and base fixing nut is fastened.

- Fasten lathing pen.
- Fasten with proper wrench.
- Start mechanic motor.
- Apply lathe knife at the place of fillings.
- When finished counter clean lathe unit.
- Machine is not used for different purposes, Produced to level the rims only

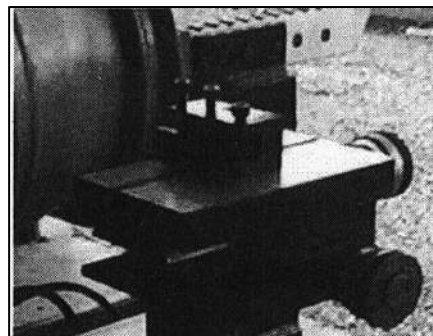

## Electric layout

POWER SUPPLY: 3x380V AC+PE 60Hz

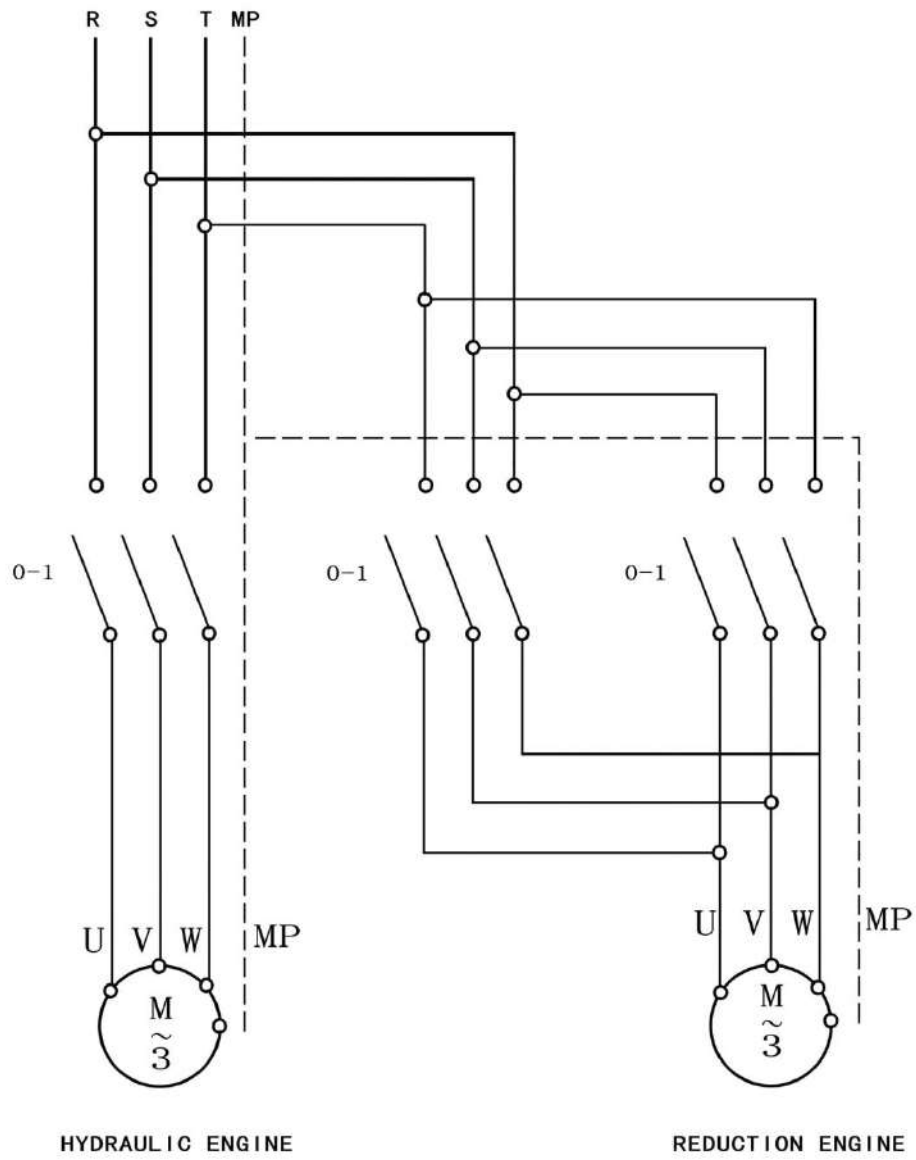

## Electric layout

POWER SUPPLY: 1x220V AC+PE 50Hz+60Hz

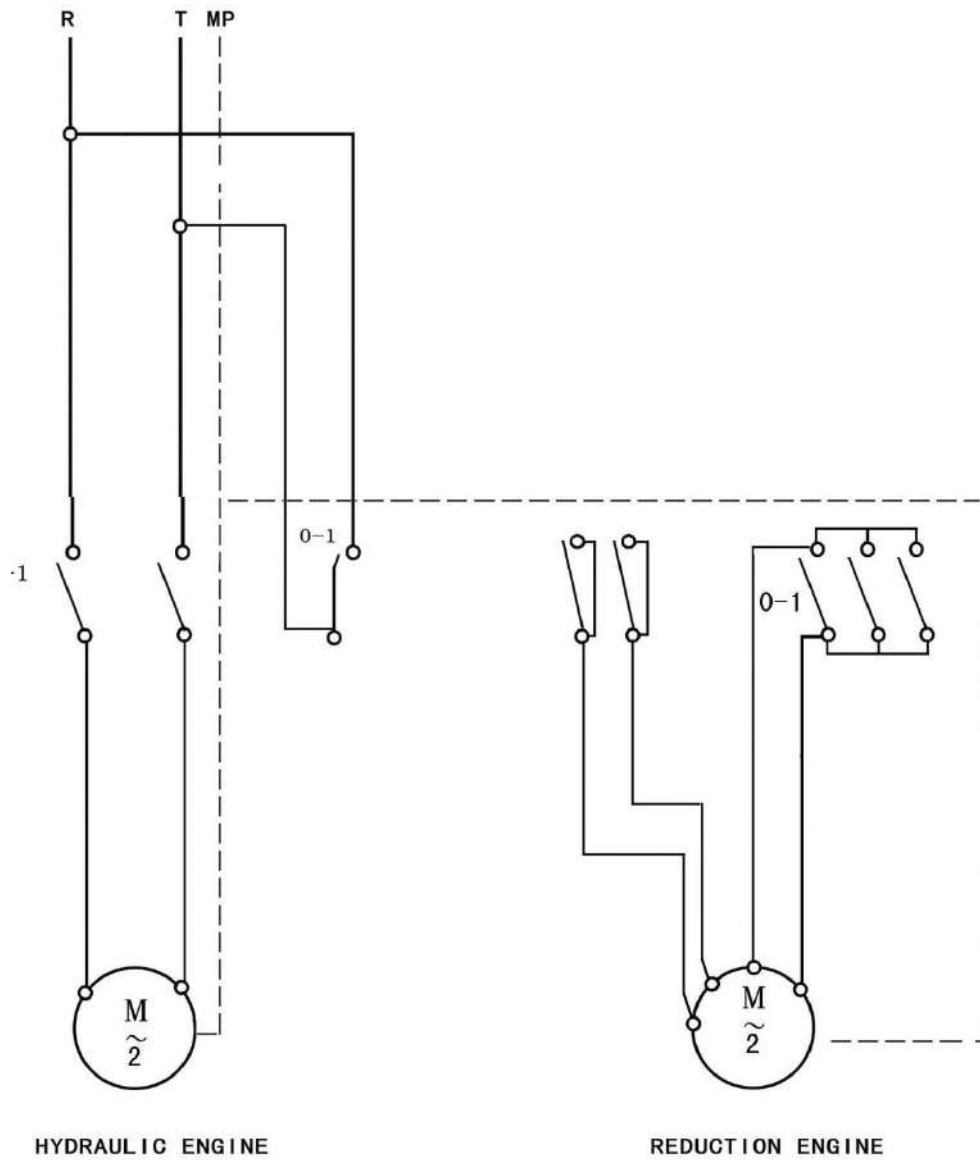

## Packing list Rim Stagtening Machine

Serial No.	Des	Specificatio	number	Remark
1	Center positioning	1#	1	
2	Center positioning	2#	1	
3	Center positioning	3#	1	
4	Center positioning	4#	1	
5	Main axle	Special	1	
6	Locking nut	Special	1	
7	Magnetic meter socket	Special	1	
8	The gasket	Special	2	
9	The lathe tool	Special	2	
10	Knife table Loking wrench	Special	1	
11	Steel Wheel fixed faceplate	Special	1	
12	Center positioning bolt	? 12	5	
13	Center positioning nut	M12	5	
14	Plug	Special	5	
15	Big supportor	Special	1	
16	Small supportor	Special	1	
17	Plan-pin	Special	1	
18	Supporting head	Special	10	
19	Supporting axle	Special	5	
20	Sleeve	? 22	1	
21	Handwheel	Special	1	