

INSTRUCTION MANUAL AND PARTS LIST

LATHE

MODEL: C6266A. CQ6280

MADE IN: YANGZHOU SUPER MACHINE TOOL CO.,LTD.
ADDRESS: No.198 HEYE WEST ROAD,YANGZHOU,CHINA

CONTENTS

Specifications of the Lathe and its Main Data	4
1. Guideline for Safety Operation	8
1-1 Safety Points for Attention.....	8
1-2 Danger of Operation.....	9
1-3 General Safe Rules for Operator of the Lathe	10
1-4 Protection of the Chuck	12
1-5 The Use of Emery Cloth in Metal Processing Can Cause Danger.....	13
1-6 Safety devices	15
2. Level of Noise	20
3. Handling and Installation	21
3-1 The Weight of the Lathe and Hoisting.....	21
3-2 Handling.....	21
3-3 Unpacking.....	21
3-4 Hoisting.....	21
3-5 Rules of Safe Hoisting.....	22
3-6 Installation.....	23
3-7 Foundation.....	23
3-8 Position the Lathe by Adjustment Iron Pad.....	23
3-9 Fix the Lathe by Anchor Screws.....	23
3-10 Lubrication Examination.....	32
3-11 Spindle Bearings of the Headstock.....	32
3-12 Cleaning.....	32
3-13 Leveling.....	32
4. Power Supply and Connection	33
5. Chuck and its Installation	36
6. Safe Operation of the Lathe	38
7. Operation System	39
7-1 Meaning and Function of Operation Signs.....	41
7-2 Electric Control.....	42
7-3 Turning and Braking of the Spindle.....	42

7-4 Speed of the Spindle.....	42
7-5 Selection of Pitch and Feed.....	42
7-6 Positive/Negative Direction of the Leading Screw.....	43
7-7 Control of the Slide of the Saddle.....	43
7-8 Operation of Feed Box.....	43
7-9 Operation of the Carriage Apron.....	44
7-10 Adjustment of Feed Safety Device.....	44
7-11 Carriage Apron Hand Wheel.....	45
7-12 Longitudinal Stop Iron of the Carriage Apron.....	45
7-13 Locking of the Saddle.....	45
7-14 Cooling.....	45
7-15 Tailstock.....	45
7-16 Mounting/Dismounting of the Saddle.....	46
8. Maintenance.....	48
8-1 Accuracy of the Lathe.....	48
8-2 Check the Headstock.....	48
8-3 Check the Tailstock.....	48
8-4 Adjustment of the Driving Belt.....	48
8-5 Adjust the Clutch of the Tailstock.....	49
8-6 Adjustment of the Brake of the Headstock.....	49
8-7 Gib of the Rail.....	50
8-8 Adjustment of Cross Leading Screw Nut.....	51
8-9 The Change Gear.....	51
9. Lubrication.....	52
9-1 The Headstock.....	52
9-2 Feeding Box.....	52
9-3 Oil Tank.....	52
9-4 Carriage Apron.....	52
9-5 Change Gear.....	52
9-6 Indication of Lubrication of the Lathe.....	53
10. Normal Troubles and Remedies.....	54
11. Parts List Assembly	56-127

Specifications of the Lathe and its Main Data

Main Data of the Lathe

Main Data of the Lathe	C6266A×1500 / C6266A×2000 / C6266A×3000		
Max. swing diameter over bed			φ 660 mm
Max. swing diameter over carriage apron			φ 440 mm
Max. swing diameter in gap			φ 900 mm
Valid length of gap before headstock			250 mm
Height to spindle center			330 mm
Distance between centers	1500 mm	/	2000 mm / 3000 mm
Width of bed			400 mm
Max. size of tool shank (W×H)			25×25 mm
Max. travel of cross slide			368 mm
Max. travel of top slide			230 mm

Main Data of Spindle

Spindle bore			φ 105 mm
Spindle head joining style			D1-8
Spindle reducing bush taper			φ 113 mm(1:20)/ MT5
Spindle speed grade			16
Spindle speed range			25~1600 rpm

Cutting Thread, Feed Range and Kind

Large screw size			φ 40 mm×2T.P.I. or φ 40 mm×12 mm
Inch thread range & kind			7/16~80 T.P.I.(54 kinds)
Metric thread range & kind			0.45~120 mm (54 kinds)
Diameter pitch range & kind			7/8~160DP (42 kinds)
Module range & kind			0.25~60MP (46 kinds)
Metric spindle longitudinal feed per revolution			0.044~1.48 mm/rev (25 kinds)
Inch spindle longitudinal feed per revolution			0.0016498~0.05497" /rev (25 kinds)
Metric spindle cross feed per revolution			0.022~0.74 mm/rev (25 kinds)
Inch spindle cross feed per revolution			0.0008326~0.02774" /rev (25 kinds)

Tailstock Data of Lathe

Travel of tailstock sleeve			235 mm
Diameter of tailstock sleeve			φ 90 mm
Inside taper of tailstock sleeve			MT5

Motor Size of Lathe

Power of main motor			7.5 kW(10HP)
---------------------	--	--	--------------

Power of cooling pump

0.09 kW(1/8HP)

Weight and Size of Lathe

Outline size (L×W×H) unit: cm	321x123x160 /	371x123x160 /	471x123x160
Packing size (L×W×H) unit: cm	324x114x184 /	374x114x184 /	474x114x184
Net weight of lathe	3065 kg /	3345 kg /	3710 kg
Gross weight of lathe	3535 kg /	3835 kg /	4310 kg

Specifications of the Lathe and its Main Data

Main Data of the Lathe

Main Data of the Lathe	CQ6280×1500 / CQ6280×2000 / CQ6280×3000
Max. swing diameter over bed	φ 800 mm
Max. swing diameter over carriage apron	φ 570 mm
Max. swing diameter in gap	φ 1035 mm
Valid length of gap before headstock	250 mm
Height to spindle center	330 mm
Distance between centers	1500 mm / 2000 mm / 3000 mm
Width of bed	400 mm
Max. size of tool shank (W×H)	25×25 mm
Max. travel of cross slide	420 mm
Max. travel of top slide	230 mm

Main Data of Spindle

Spindle bore	φ 105 mm
Spindle head joining style	D1-8
Spindle reducing bush taper	φ 113 mm(1:20)/ MT5
Spindle speed grade	16
Spindle speed range	25~1600 rpm

Cutting Thread, Feed Range and Kind

Large screw size	φ 40 mm×2T.P.I. or φ 40 mm×12 mm
Inch thread range & kind	7/16~80 T.P.I.(54 kinds)
Metric thread range & kind	0.45~120 mm (54 kinds)
Diameter pitch range & kind	7/8~160DP (42 kinds)
Module range & kind	0.25~60MP (46 kinds)
Metric spindle longitudinal feed per revolution	0.044~1.48 mm/rev (25 kinds)
Inch spindle longitudinal feed per revolution	0.0016498~0.05497" /rev (25 kinds)
Metric spindle cross feed per revolution	0.022~0.74 mm/rev (25 kinds)
Inch spindle cross feed per revolution	0.0008326~0.02774" /rev (25 kinds)

Tailstock Data of Lathe

Travel of tailstock sleeve	235 mm
Diameter of tailstock sleeve	φ 90 mm
Inside taper of tailstock sleeve	MT5

Motor Size of Lathe

Power of main motor	7.5 kW or 11kW
---------------------	----------------

Power of cooling pump

0.09 kW(1/8HP)

Weight and Size of Lathe

Outline size (L×W×H) unit: cm	321x123x167 /	371x123x167 /	471x123x167
Packing size (L×W×H) unit: cm	324x114x191 /	374x114x191 /	474x114x191
Net weight of lathe	3220 kg /	3505 kg /	3870 kg
Gross weight of lathe	3705 kg /	4005 kg /	4480 kg

1. Guideline for Safety Operation

The lathe is a high speed and powerful machine and can cause danger if operate it improperly.

Before operating the lathe please read the following guidelines of safety operation. Take care and observe to make the lathe be under normal operation environment so as to avoid danger.

The lathe is in accordance with GB15760-1995 <General Technical Condition of Safety Protection of Metal Cutting Machine> issued by the state.

The manual covers information and hints necessary for proper and safe operation of the lathe.

It is required the operator of the lathe should accept suitable technical training before operating the machine, own skills to operate it and hold the certificate of operation; or he should be trained under the close supervision of somebody who can skillfully operate the machine.

The lathe should be operated under the environmental temperature of +5°C - +40°C; the elevation up to 1000 m; the relative humidity of 50% when ambient temperature is +40°C or higher relative humidity if ambient temperature is lower.

The manual also covers related information for those who owns necessary skills or appointed persons to make suitable maintenance upon the machine.

1-1 Safety Points for Attention

1. Keep the lathe and the working area clean and in good order.
2. All guard devices and cover plates should be on the place; the side cover should be closed.
3. Do not place any objects in the processing area of the lathe as they may bump with rotating or moving parts.
4. Do not contact or leap over moving or rotating parts of the lathe.
5. Before starting the lathe, you should understand how to stop it.
6. The lathe cannot be operated under overload.
7. Stop running of the lathe immediately in case any accident occurs.
8. When mounting the chuck or other attachment on the spindle, switch off power supply of the lathe to prevent rotation of the spindle.
9. Do not mount the jigger if it is not checked or confirmed to be compatible with the lathe.
10. Check the center you used if its load capacity can meet with requirement.
11. Switch off power supply before leaving the lathe.
12. The maximum weight of the workpiece on the lathe is 500 kg.
13. The chuck should be properly and firmly mounted on the spindle of the lathe.
14. Take care that the workpiece should be gripped firmly and the speed of the spindle cannot exceed the safe speed of the chuck.

15. As it is possible to contact with human body, especially when the material with small diameter is used, it is not allowed in any case that the rod material cannot extend out the end of the spindle of the headstock which has no special guard and relative support.
16. There is the label of speed limit for the chuck and that no speed change is allowed in operation at the lower right corner of the headstock, the electric warning board at the electric cabinet (box) and that no touch on the workpiece (or chuck) when it is rotating on the guard of the chuck to remind you to take care.

1-2 Danger of Operation

When operating the lathe you should fully understand the danger of following operations:

1) Cutting Fluid

The cutting fluid is hazardous to human body. To contact the cutting fluid continuously especially the original fluid, it can cause the skin allergic or ill if seriously, even the emulsion can also cause the same. Therefore following precautions should be taken:

- a. Avoid any unnecessary contact.
- b. Put on the protective clothes.
- c. Adopt guard shield or plate.
- d. Do not wear oily or dirt clothes.
- e. Clean all parts of the body where the cutting fluid is contacted after work.
- f. Do not mix different cutting fluids.
- g. Replace the cutting fluid regularly.
- h. Correctly treat the cutting fluid.

2) Safe Operation of the Chuck of the Lathe

All jiggers of work pieces should have clear labels of the maximum safe speed and the speed of the spindle can never exceed it. It should point out that the maximum safe speed on the label is supposed under ideal work condition and lower speed of the spindle should be selected in following cases:

- a. Adopt the chuck to jig the workpiece under noisy work condition.
- b. If the chuck is surely damaged, it is dangerous to operate under high speed, especially when the chuck of grey pig iron is used it shall break if it is something damaged.
- c. If no gripping force is known before jiggling.
- d. All factors such as strength of the workpiece to be jigged, balance of the jiggling faces and the workpiece etc. can largely affect the maximum safe speed.

When the workpiece is rotation, it may not be jugged firmly due to the role of centrifugal force and following factors may be involved:

- a. The speed is too high.
- b. The weight and type of the claws are off standard.
- c. The working radius of the claw is unsuitable.
- d. The claw has bad lubrication.
- e. It is unbalanced.
- f. The dynamic factor is not considered in the jugging force.
- g. Too large cutting force.
- h. Is the workpiece jugged internally or externally?

These factors should be seriously considered as they can cause different influence in different purposes. The manufacturer cannot provide concrete data for general use as they are beyond the range controlled by the manufacturer of the machine.

1-3 General Safe Rules for Operator of the Lathe

1. When jugging the workpiece, it cannot have oil or grease;
All parts should be jugged firmly;
Do not intend to jig the workpiece which is unsuitable or hardly to jig well;
Do not jig the workpiece exceeding the weight allowed by the lathe;
Master suitable hoisting method when the workpiece is hoisted.
2. Ensure to remove oil or grease on handy tools and operation grippers;
Ensure the structures of handy tools and operation grippers are suitable to touch safely by hand.
3. When operating the handy tool or the operation gripper, it should be gripped firmly;
Select suitable position to grasp on the handy tool or the operation gripper;
You cannot grasp the handy tool or the operation gripper on unsuitable position;
You cannot operate with excessive force.
4. Grasp the handy tool or the operation gripper on recommended positions.
5. Do not allow to leave other handy tool or operation gripper on the chuck.
6. Do not allow to use broken, damaged or defected tool.
7. Ensure the workpiece is jugged firmly on the chuck or other jiggers.
8. Take special care of irregular workpiece.
9. Take care of large flashes and burrs on the workpiece.
10. Always take care to select correct tool in work.
11. It is not allowed to leave other unfixed handy tool or operation gripper on the chuck.
12. Do not allow to use the tool without the handle.
13. Always adopt the chuck, the follow rest and the center to support the workpiece.
14. The workpiece should have correct position in the hexagon hole and the groove of

the screwdriver.

15. Take care that the locking screw should be tightened.
16. Do not make preparation work in a hurry.
17. Never use the substitute tool if no suitable tool is available or prepared in the workshop.
18. Do not allow to move away the guard plate or to open the protection door when the lathe is switched on.
19. Do not let your hands or body be within the working area of moving parts.
Take care to move parts of the lathe which could drop down.
Take care of relative position between the hand or the body and the lathe.
Take care of the tool to be grasped and other parts inserted in the chuck or the workpiece.
Do not let your hands or body be on the place where they could be hurt by the chuck or the workpiece.
20. Take care not to push the handle, to operate the clutch or to witch on power supply to cause accident.
21. Master every function and all kinds of operation methods.
22. Never put your hands on the chuck or the workpiece to stop rotation of the spindle.
23. For the lathe driven by the clutch, in case the clutch is disengaged, the spindle should be stopped running otherwise the clutch or the brake device should be adjusted.
24. When the lathe is not in use, ensure to switch off power supply of the lathe.
25. Stop the rotation of the chuck before replacing the new workpiece.
26. Always take care to check if driving of the chuck, the belt pulley and driving parts are loose.
27. When the handle of the chuck is in the chuck, never start the spindle.
28. Do not operate the laths if the attention is not concentrated in order to avoid accident.
29. When preparing to make other operation of the lathe such as the tailstock, take care to avoid danger such as bumping or dropping.
30. Take care of guard cover of the chuck and other covers which cannot be loosened.
31. Put on the safety cap to operate the lathe if the operator has long hair to avoid danger due to hair is wounded by rotating parts of the machine.
32. Take special care to make operation if you are closing to rotating part of the machine.
33. Always pay attention to filing and deburring:
Take special care when the file or the deburring tool is closing to the chuck;
The file or the deburring tool could bump the chuck.
34. For the lathe driven by the clutch, take care that the clutch should be at the position the lathe is stopped when making measurement.

35. Take care of rotating and stopping positions of the spindle when hand is on the handle of the clutch.
36. Ensure the spindle of the lathe should be at the stop position when measuring the workpiece jugged on the chuck.
37. When the measuring meter is used on the lathe, ensure the motor is at the stop status.
38. Wear protective gears met with safe standard before making operation on the lathe;
It is not allowed if taking off protective gears in a short period of time before making operation on the lathe;
Wear protective gears properly.
39. Take care of cuttings flying out from the lathe.
40. Select suitable guard plate on the operation position.
41. Never leap over or go around the chuck or the workpiece to make adjustment when they are in running status;
Never leap over or go around the chuck or the workpiece to take something;
Take care of the place the workpiece is put when making adjustment of the lathe or the workpiece;
Never leap over or go around the chuck or the workpiece to move the tool/lathe to other position;
Never leap over or go around the chuck or the workpiece to tighten parts on the lathe;
Never leap over or go around the chuck or the workpiece to remove iron chips.
42. Master suitable method to load, and never apply force from unsuitable position.
43. Never mount the workpiece too large or heavy toward the lathe.
44. Never mount the workpiece too large or heavy toward the operator.
45. Use necessary tools to treat the workpiece.
46. Never apply excessive force on the attachment or the operation lever.
47. Take care to jig the workpiece firmly.
48. Tighten all claws, nuts, screws and fasteners.
49. Always take care to use correct equipment.
50. Never make cutting beyond the ability of the lathe.
51. Do not apply excessive force to polish or to deburr.
52. Always take care to adopt suitable tool to deburr. Do not deburr in a hurry and take care of burrs on the chuck and the workpiece.
53. Switch off power supply to stop all movements of the lathe before replacing the exchange gears.
54. Take care if the chuck/parts could drop down when the lathe is in operation.

1-4 Protection of the Chuck

The lathe is equipped with the guard of the chuck (option), which is suitable for the standard chuck.

In case the chuck guard is equipped on the lathe, it should be in a closed status before the spindle is running.

1) When the machine is equipped with larger chuck, the chuck guard should be replaced with one which has corresponding diameter with that of the chuck.

It is suggested that claws cannot extend out the outer diameter of the chuck in order to avoid bump with the chuck guard. For the sake of safe operation, always take care not to extend claws out of the outer diameter of the chuck.

2) When the face chuck is used, the chuck guard should be removed. If it is indeed required by customer, the special chuck guard can be provided but it should be confirmed that only the face chuck is used and any case should be responsible by customer himself.

1-5 The Use of Emery Cloth in Metal Processing Can Cause Danger

In all accidents occurred on the lathe, most are from the use of emery cloth to cause breakage of fingers, or even to amputate occasionally.

When workpieces with different shapes are rotating on the lathe, if using emery cloth to deburr, to polish or to process finished sizes, it can cause the accident when winding emery cloth on the workpiece to be ground by two hands. If winding the emery cloth on the finger or to make rough grinding, the finger could be seized firmly to cause serious injury.

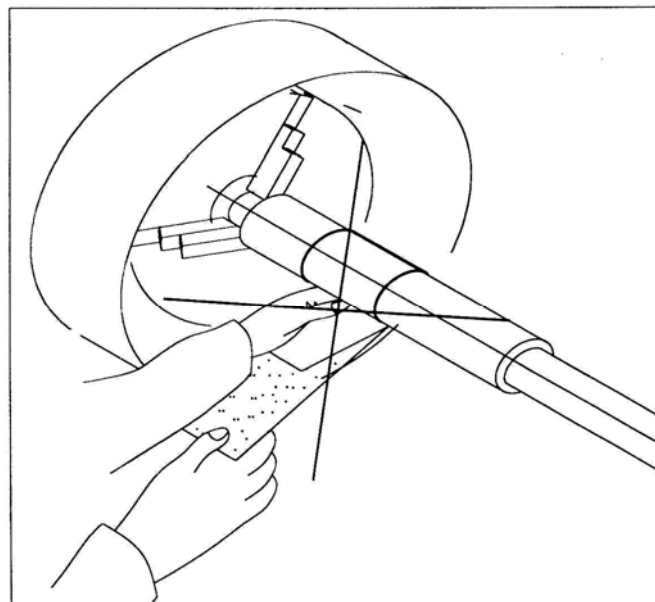

Precautions

The operator should have certain recognition and knowledge on the necessity to

treat part by emery cloth on the lathe.

It is not needed to process by emery cloth in following cases:

If the requirement of the surface roughness is not so high;

Make processing by turning or on special polisher or grinding machine, the finished sizes and surface roughness can be achieved well.

If technological rule defines that the workpiece should be ground by emery cloth, then the emery cloth should be used in following cases:

a. Nail the emery cloth on a quality wood board to grind;

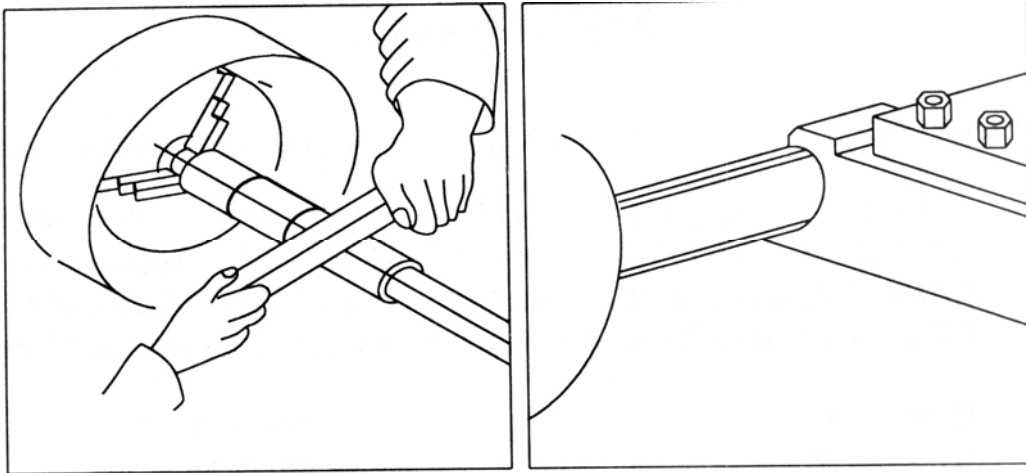

b. The emery cloth is fixed on and jigged by the tool holder to grind.

c. The “Robust Grinder” consists of two pieces of jointed wood board and the emery cloth to make grinding and the workpiece to be polished can go through its hole.

d. The polish is made by the wire brush stuck with abrasive material.

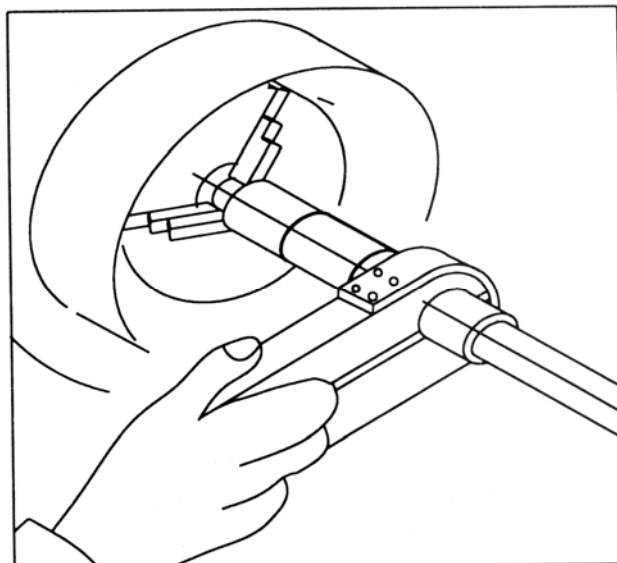

Apply force at the both ends of the emery cloth to pull it upward. Never pull it loosely or wind it on your finger or on the workpiece.

When the end of the workpiece is polished, only a short piece of the emery cloth shall be used as it cannot be wound.

When polish by the emery cloth is made, never operate by wearing gloves.

1-6 Safety devices

Operate the lathe only with properly functioning safety devices.

Stop the lathe immediately if there is a failure in the safety device or if it is not functioning for some reason.

It is your responsibility!

If the safety device has been activated or has failed, the lathe must only be operated again when

- the cause of the failure has been removed,
- you have made sure that there is no existing danger for persons or objects.

WARNING!

If you bypass, remove or override a safety device in any other way, you are endangering yourself and other persons working on the lathe. The possible consequences are the following

- **injuries due to components or parts of components flying off at high speed,**
- **contact with rotating parts,**
- **fatal electrocution,**
- **pulling-in of clothes.**

The lathe includes the following safety devices:

- a lockable main switch,
- an EMERGENCY-STOP button,
- a protective cover on the headstock with position switch,
- a lathe chuck protection with position switch,
- a recoil spring as protective cover on the guide spindle, the coil spring prevents the pulling-in of clothes into the guide spindle,
 - chip protection,
 - securing screw
- an overload clutch on the feed shaft,
- safety screws for the Camlock bolts on the workpiece holder.

a. Lockable main switch

In the position "0", the lockable main switch can be secured against accidental or non-authorized switching-on by means of a padlock.

When the main switch is switched off, the current supply is being interrupted.

Except for the areas marked by the ideogram in the margin. In these areas, there might be voltage, even if the main switch is being switched off.



main switch

WARNING!

Dangerous voltage exists even if the main switch is switched off.

In the areas marked by the ideogram in the margin, there might be voltage, even if the main switch is switched off.

b. EMERGENCY-STOP button

The EMERGENCY-STOP button switches the lathe off.

After actuating the switch, turn it to the right, in order to restart the lathe.

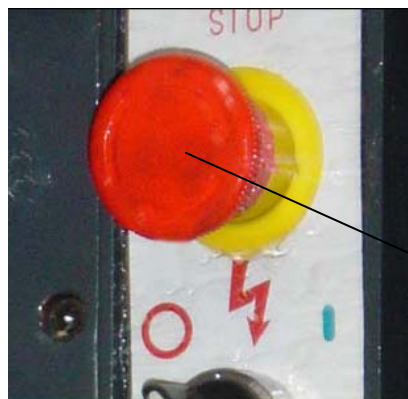

EMERGENCY-
STOP button

c. Protective cover on the headstock

The headstock of the lathe is provided with a protective cover and a position switch.

The lathe only starts when the protective cover is mounted.



positions switch

WARNING!

Only remove the protective cover when the main switch of the lathe is turned off and secured by a padlock.

d. Lathe chuck protection with position switch

The lathe is provided with a lathe chuck protection. The lathe can only be switched on if the lathe chuck protection is closed.

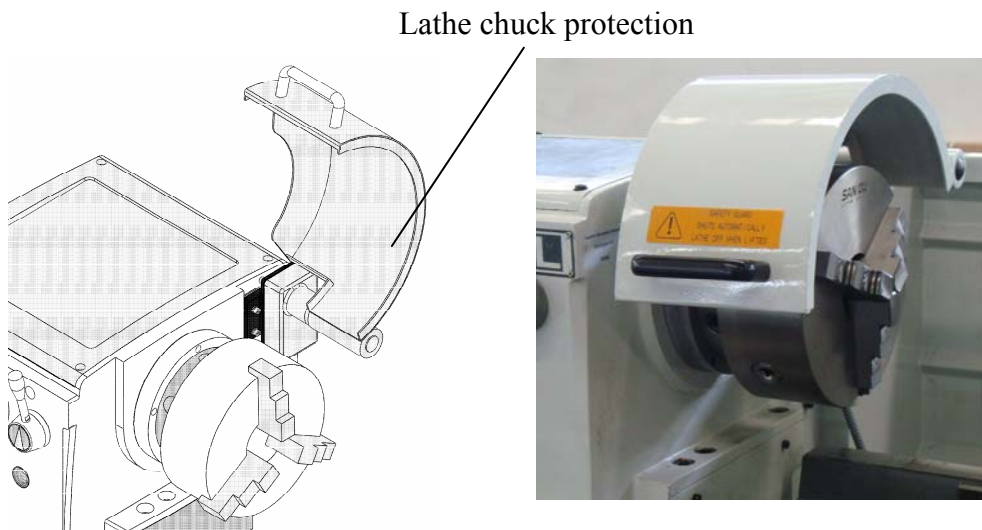

Lathe chuck protection

e. Chip protection

The lathe is provided with a protective cover for the tool cutting chip.

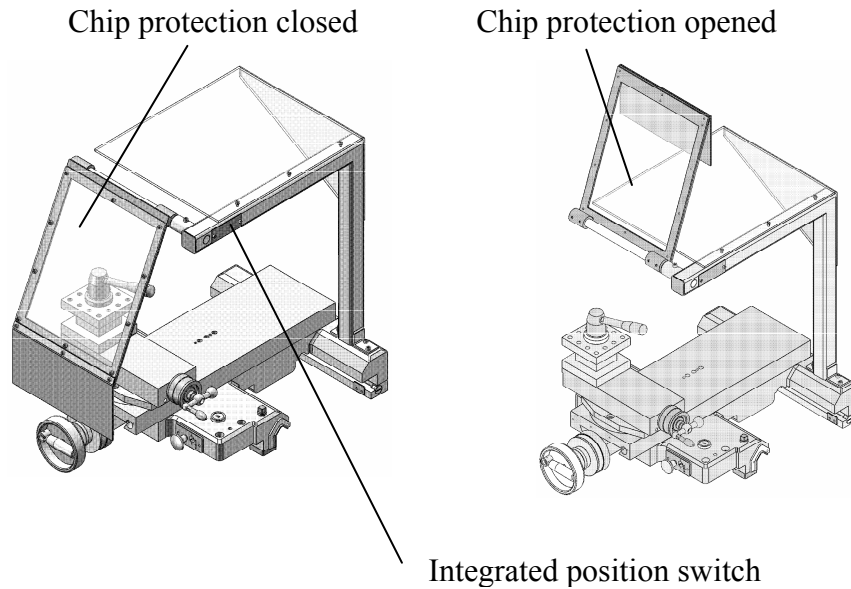

f. securing screw

Tighten the securing screw at the end of the lathe bed in order to prevent the tailstock from unintentional drawing-out of the lathe bed.

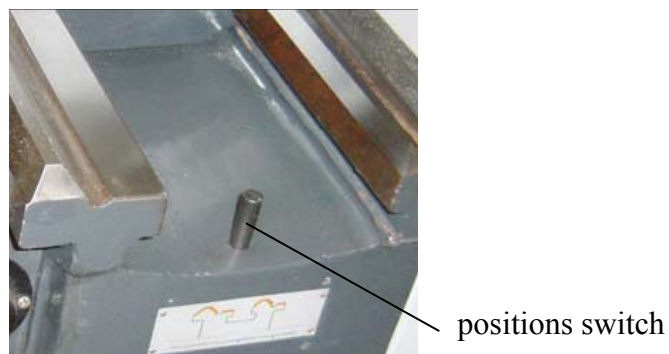

Safety check

Check the lathe at least once per shift. Inform the person responsible immediately of any damage, defect or change in the operating function.

Check all safety devices

- at the beginning of each shift (with the machine stopped),
- once a week (with the machine in operation),
- after every maintenance and repair work.

Check that the prohibition, warning and information labels as well as the markings on the lathe

- are legible (clean them, if necessary),
- are complete.

2. Level of Noise

According to GB/T16769-1997 <Measurement Method of Sound-Pressure-Level of Metal Cutting Machine>, measure the noise at six positions being one meter far from the lathe. The maximum noise should be less than 85dB (A) .

Note: The measurement should be made at the spindle with standard chuck at the maximum speed.

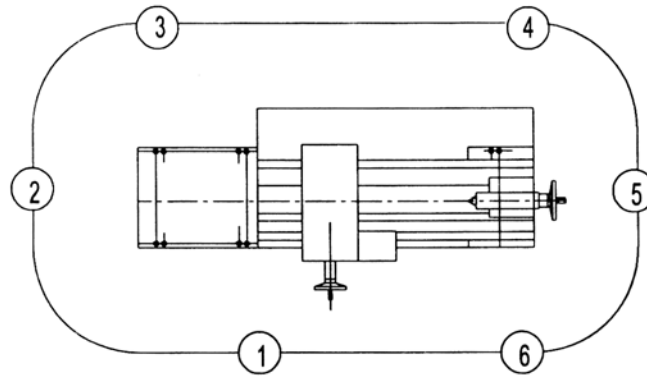

3. Handling and Installation

3-1 The Weight of the Lathe and Hoisting

The weight of the lathe is shown on the manual.

Ensure that the hoister has enough hoisting capacity before hoisting.

Preparations and safety examination:

1. Remove all unfixed devices;
2. Fix the tail on the tail end of the bed;
3. Fix the saddle on the bed and tighten the fixation press plate on the tail of the saddle;
4. Ensure screw, pin and fixation bolts on the ring of the hoister are reliably tightened;
5. Only correct hoister can be used;
6. Check ropes if they are robust and reliable in case they are used.

Do not wind the hoisting tool around the bed as it can cause curvature and damage of the leading screw and the smooth bar.

3-2 Handling

When handling the packed lathe, tie ropes as per the hoisting mark and positions on the packing case to hoist, unload and place the machine levelly and stably without over tilting.

3-3 Unpacking

After unpacking, first of all check appearance of the lathe and check attachments, tools and documents as per the packing list.

3-4 Hoisting

For the lathe with central distance of 1500 mm, 2000 mm or 3000 mm, the hoisting tools should be set at the first reinforced bar nearing the spindle box of the bed and the furthest part of the bed. Put the wooden pad nearing the guide rail for the hoisting tool to avoid bumping the guide rail.

Hoist the machine gently off the ground, and make further adjustment of position of the saddle if necessary so as to make hoisting more balanced.

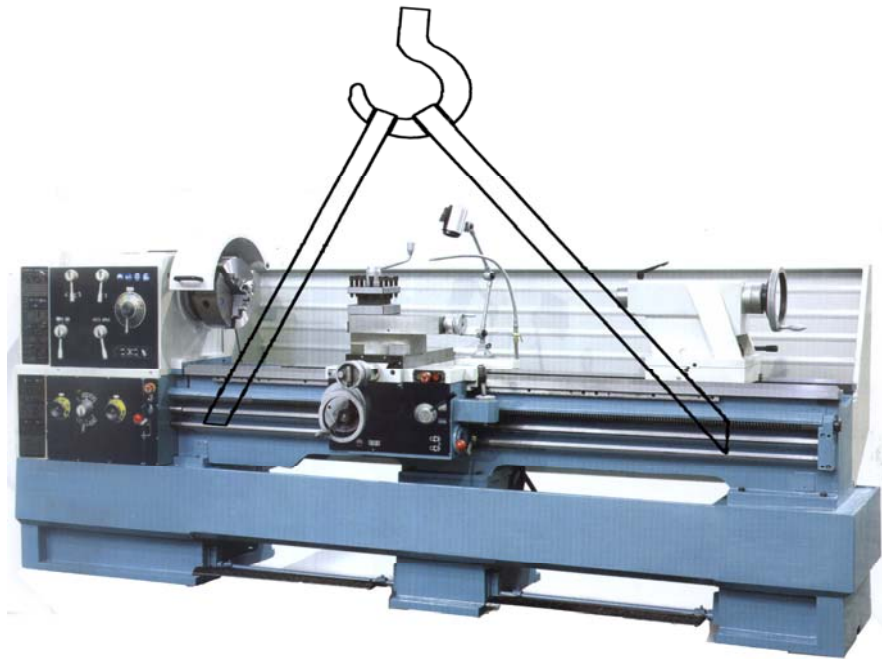

3-5 Rules of Safe Hoisting

1. Do not let the hoister operate under the overload status.
2. Do not use damaged hoisting tools.
3. Position the hoisting tool correctly and do not place it on the sharp corner or let slide over the edge angle or along the edge of the machine.
4. Do not drop down the object.
5. Correctly position the hoisting tool for easy removal later.
6. Adopt smooth hook with inner radius no less than 50 mm.
7. Avoid to place over one hook on the same hoisting tool.
8. Avoid acid, alkaline and other dangerous articles.
9. The hoisting tool cannot be polluted by oil dirt.
10. Take care that friction could occur between the hoisting tool and the machine due to vibration in the course of transportation. Therefore the hoisting tool should have protect sleeve.

The hoisting tool is made of 100% polyester materials or steel wire with enough strength. It is suggested to put the protect sleeve on the hoisting tool to prevent its damage caused by sharp object.

Each set of the hoisting tool should have clear mark of safe working load with the safe coefficient of 6:1.

For the sake of safety, the hoisting tool should be coated with safe colors.

Make an overall check on the hoisting tool regularly.

3-6 Installation

The lathe should be placed on the horizontal ground with robust foundation with enough space around it for easy processing and service. The lathe should be fixed on the foundation by bolts so as to make its performance into full play. It can be put into operation immediately after the level adjustment is made.

3-7 Foundation

The steel pad should be placed under the screws for level adjustment no matter the adjustment iron is used or the lathe is fixed by screws.

The steel pad has a thickness of 15-21 mm and the diameter of 50-80 mm.

3-8 Position the Lathe by Adjustment Iron Pad

Place 8 iron pads on the base of the lathe to level the lathe or position the lathe on the foundation and adjust 8 leveling screws to make the load distributed evenly. Readjust the lathe one week later by the precision leveler and it can then be put into formal use.

3-9 Fix the Lathe by Anchor Screws

Shown as the foundation drawing, position the lathe on 8 anchor bolts on the foundation as per its sizes.

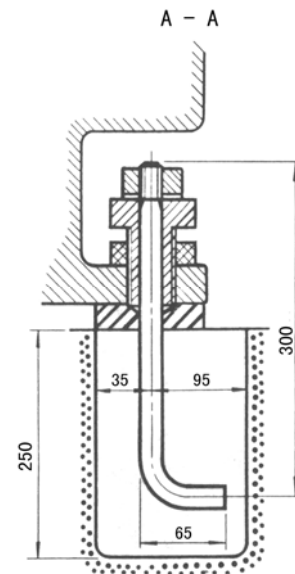

C6266A Foundation Drawing

Limit Position of Tailstock Moving Backward

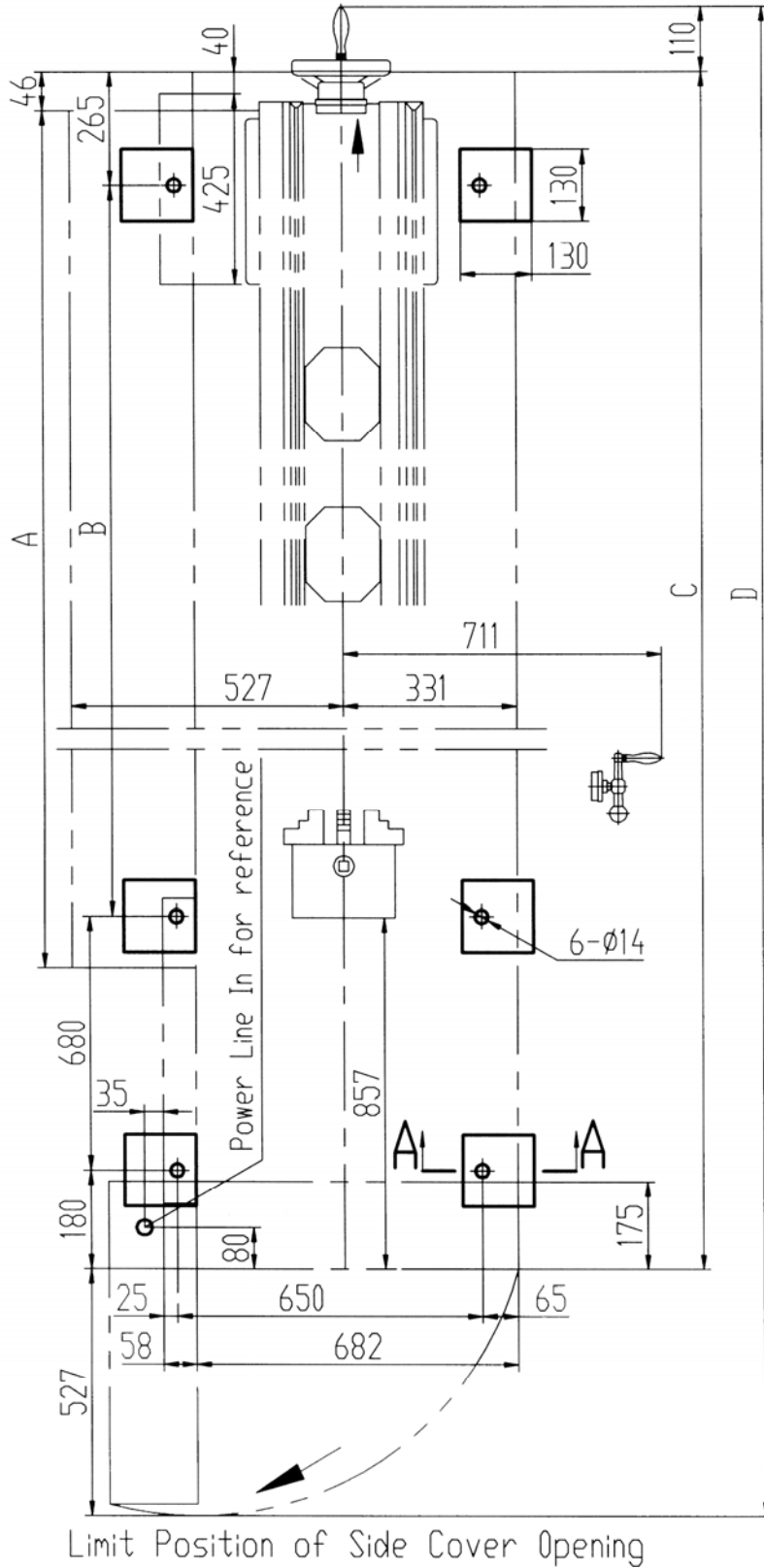

	A	B	C	D
	2340	2025	3150	3787
Distance of Centers 1500mm				

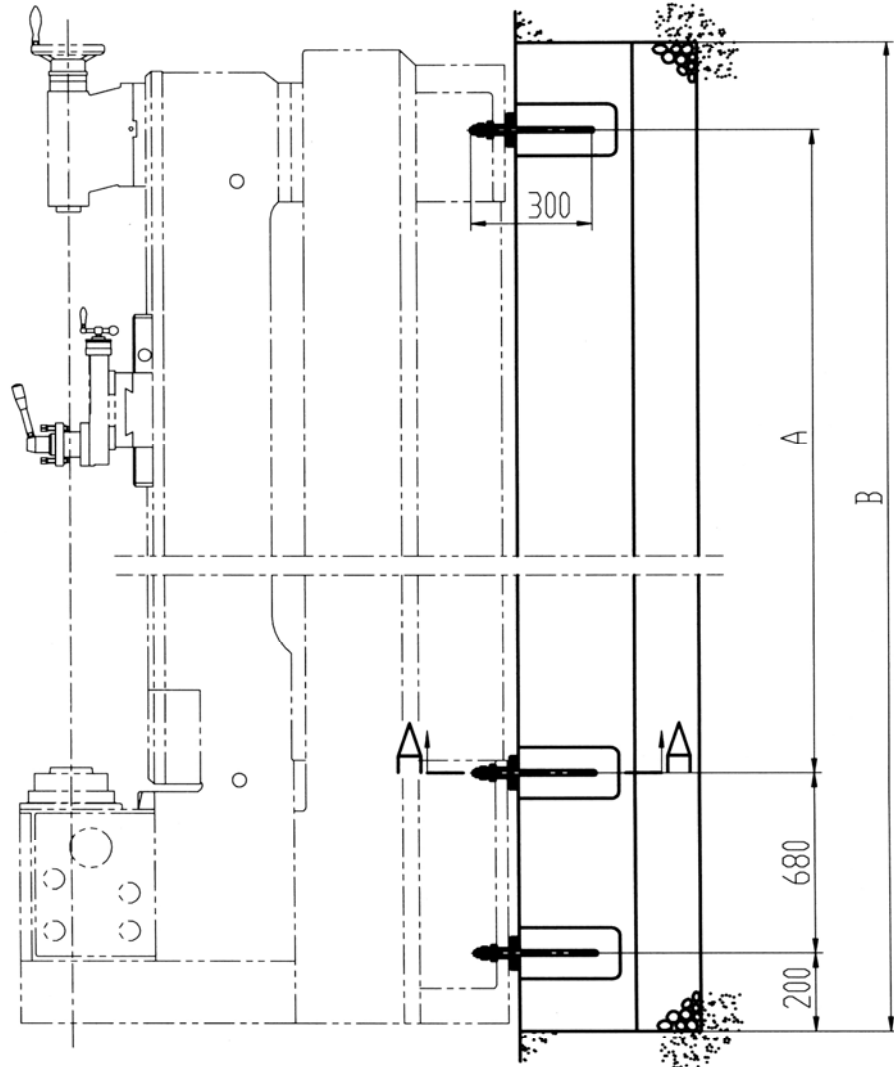
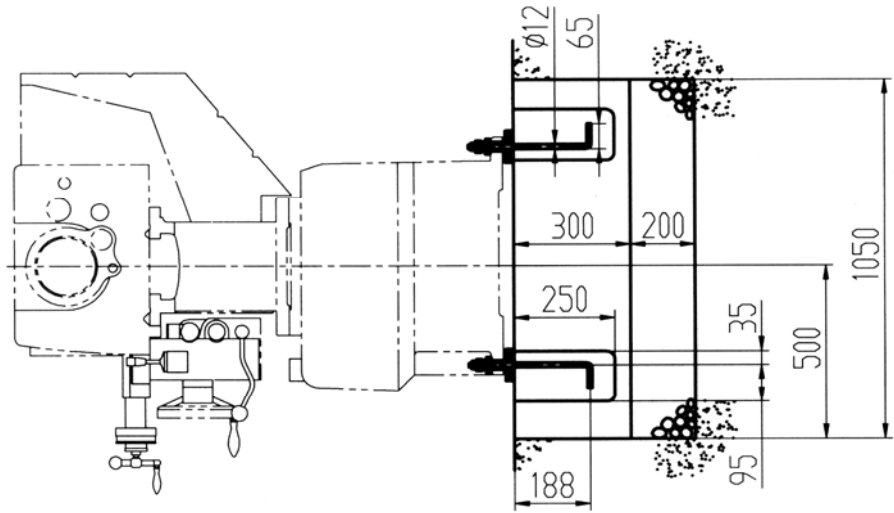

	A	B
Distance of Centers 1500mm	2025	3190

C6266A Foundation Drawing

Limit Position of Tailstock Moving Backward

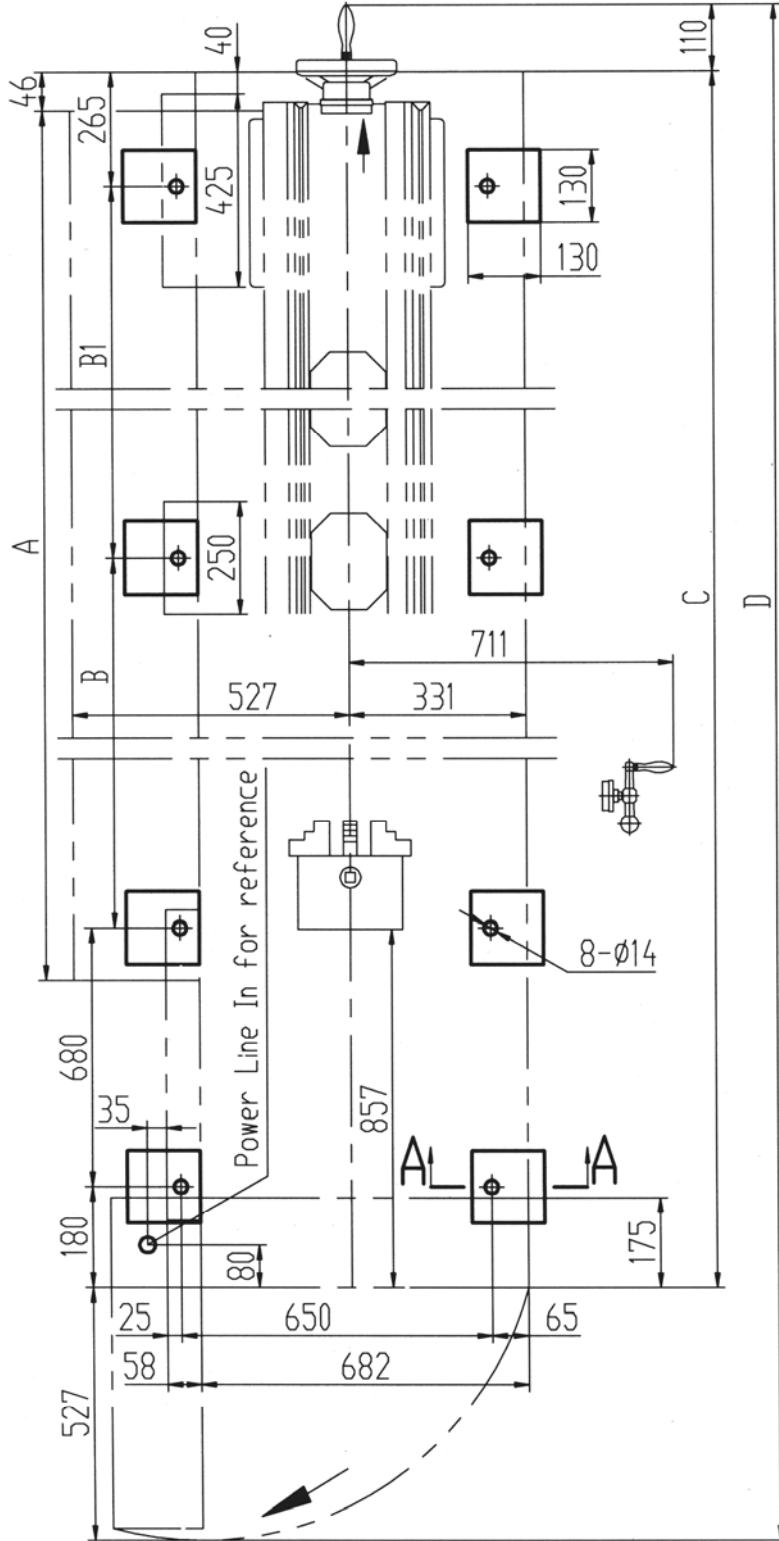

Limit Position of Side Cover Opening

	A	B	B1	C	D
Distance of Centers 2000mm	2840	1185	1340	3650	4287
Distance of Centers 3000mm	3840	1685	1840	4650	5287

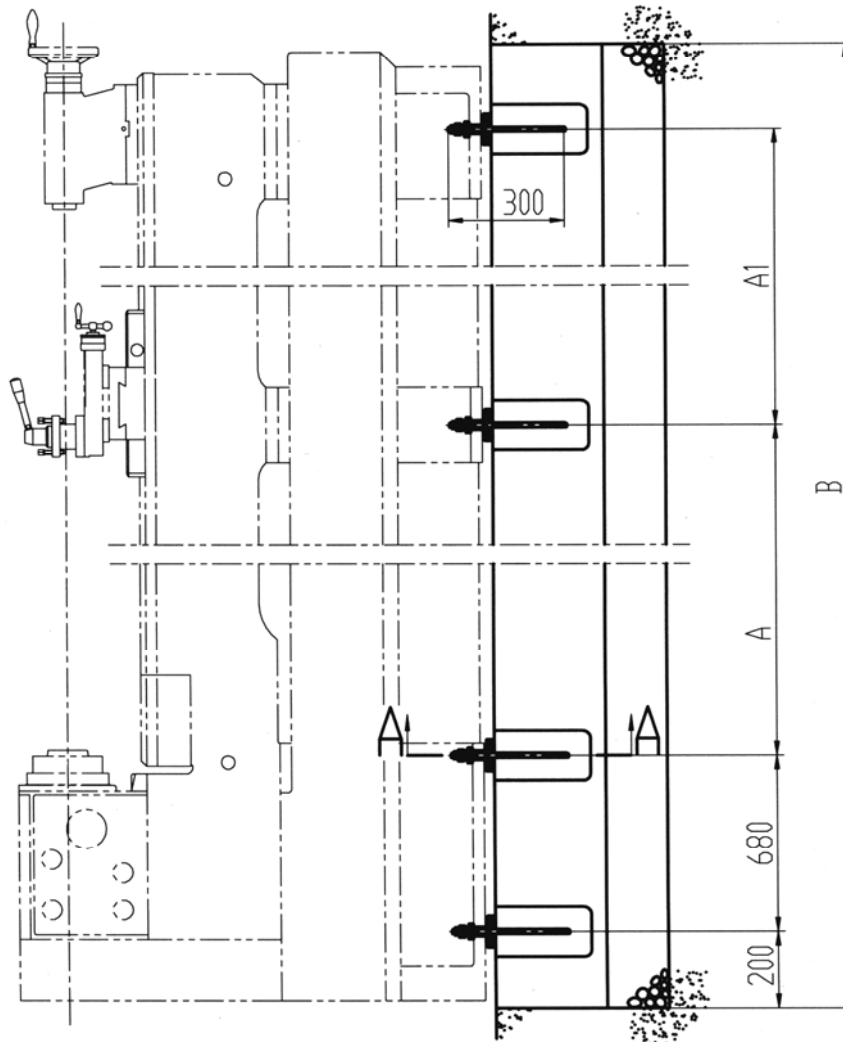
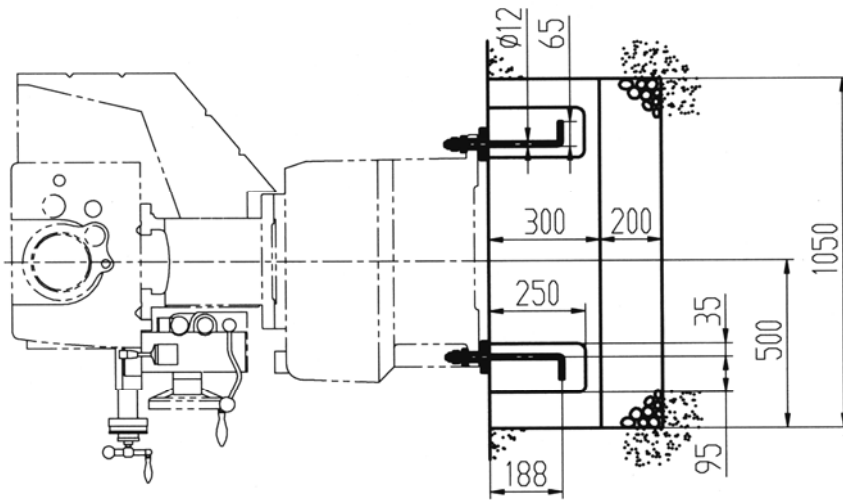

	A	A1	B
Distance of Centers 2000mm	1185	1340	3690
Distance of Centers 3000mm	1685	1840	4690

CQ6280 Foundation Drawing

Limit Position of Tailstock Moving Backward

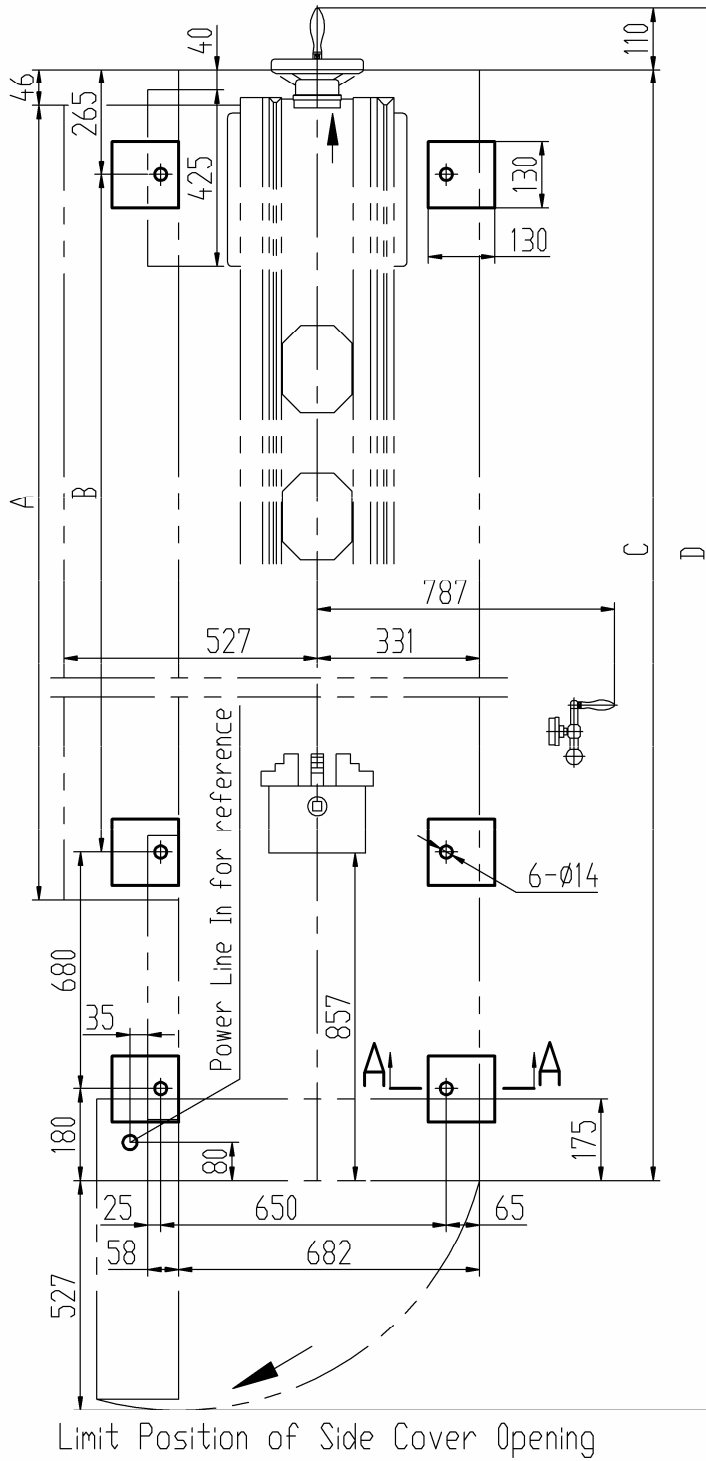

	A	B	C	D
Distance of Centers 1500mm	2340	2025	3150	3787

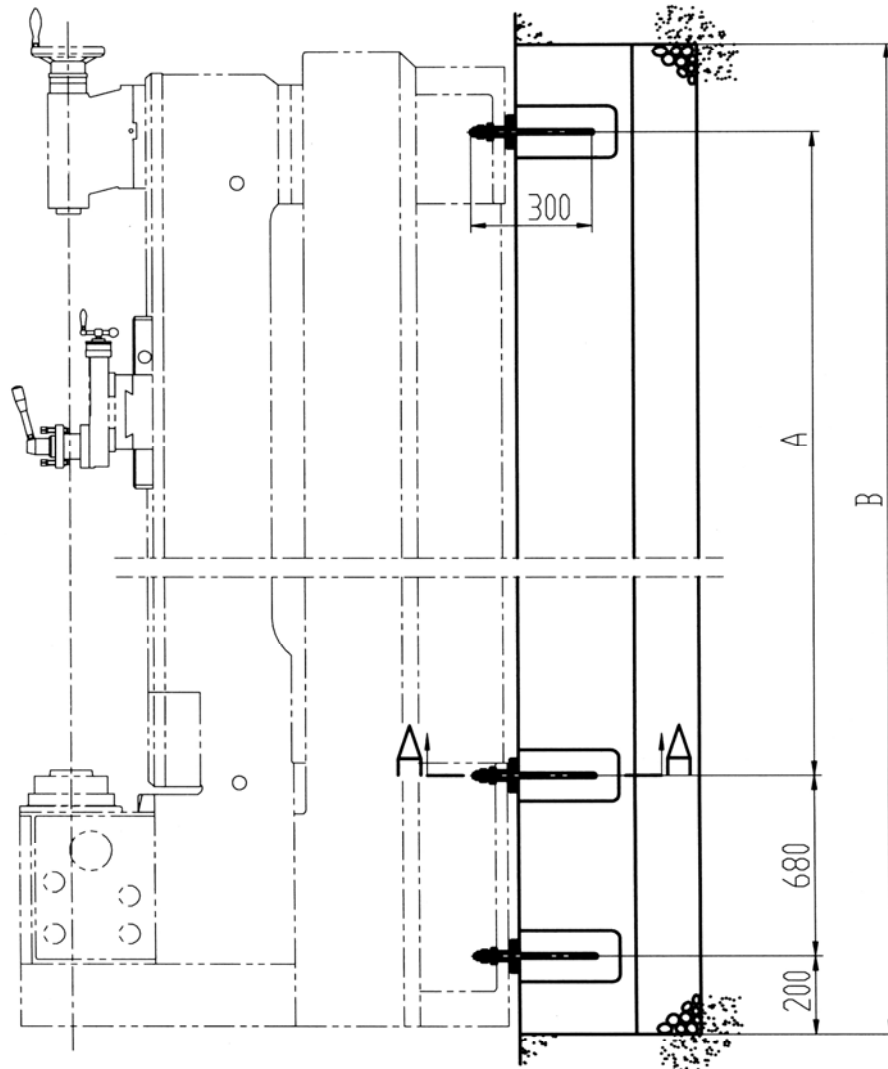
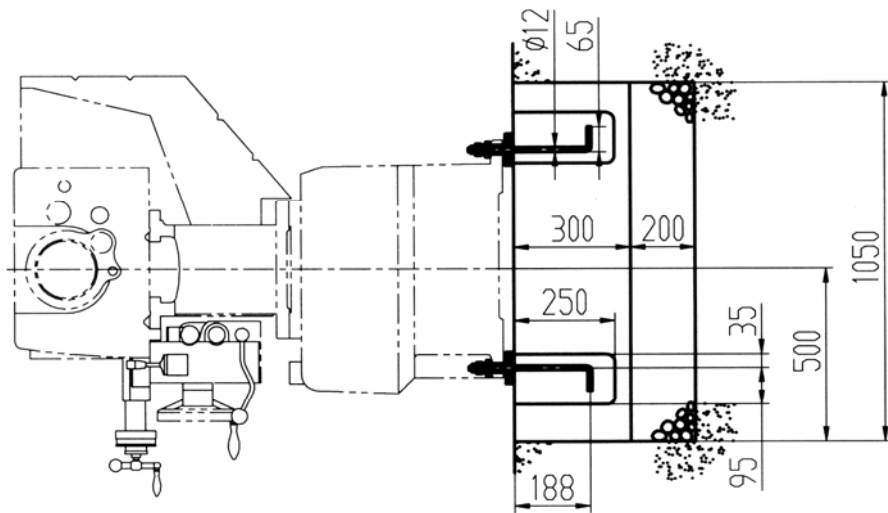

	A	B
Distance of Centers 1500mm	2025	3190

CQ6280 Foundation Drawing

Limit Position of Tailstock Moving Backward

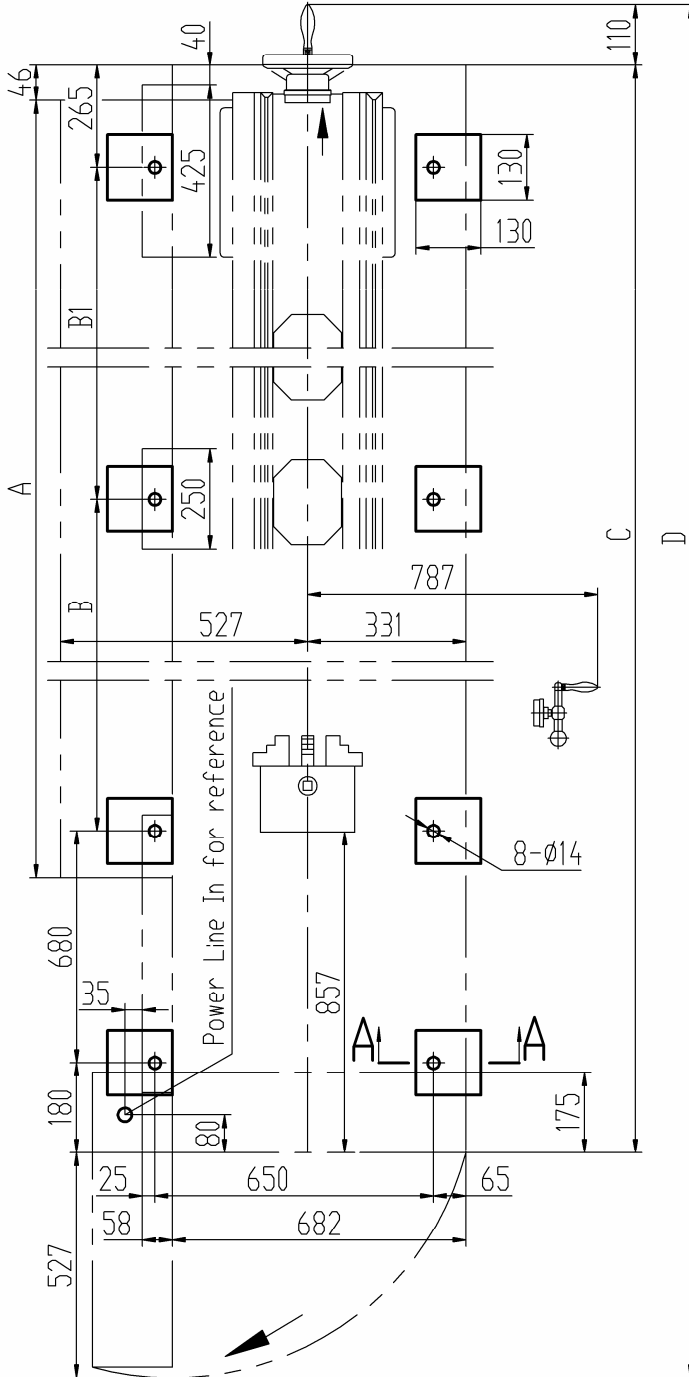

Limit Position of Side Cover Opening

	A	B	B1	C	D
Distance of Centers 2000mm	2840	1185	1340	3650	4287
Distance of Centers 3000mm	3840	1685	1840	4650	5287

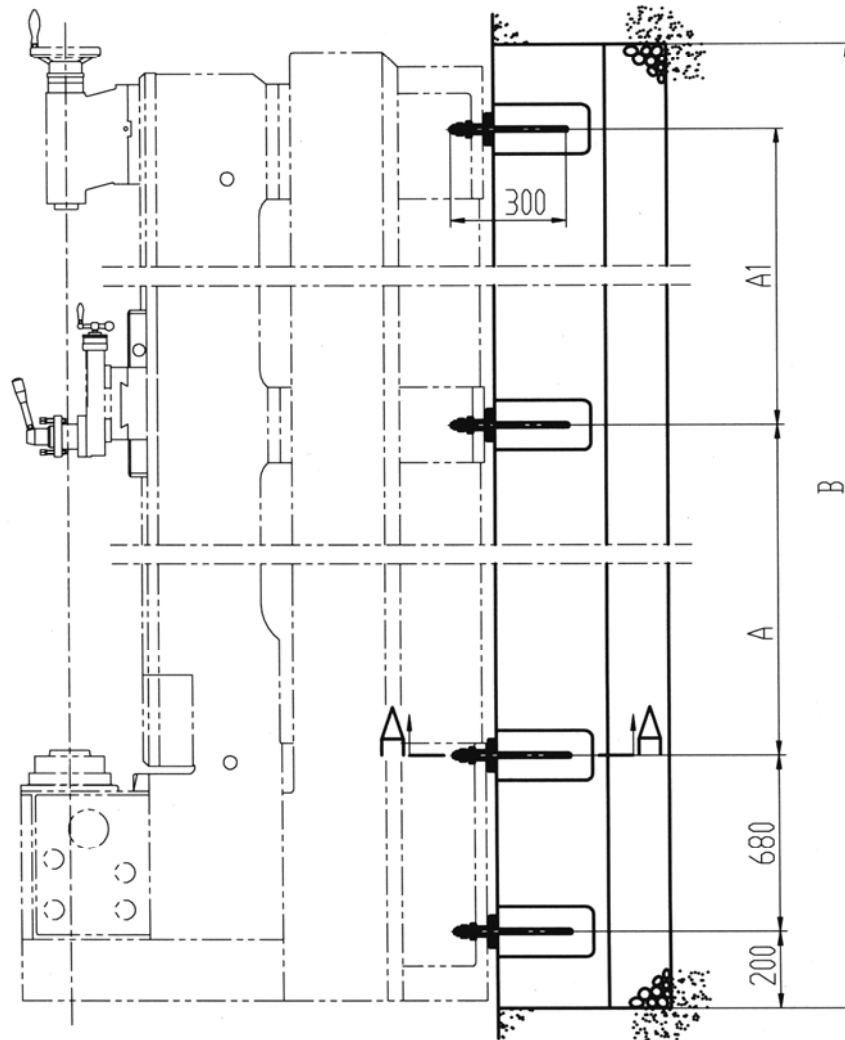
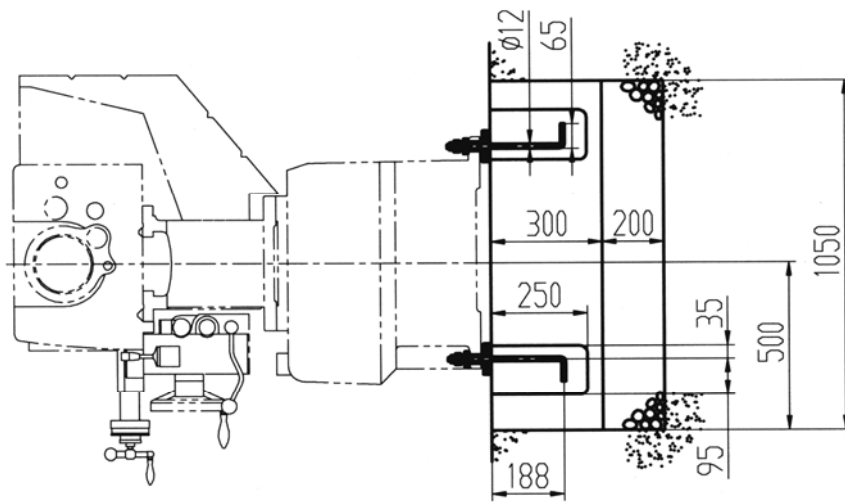

	A	A1	B
Distance of Centers 2000mm	1185	1340	3690
Distance of Centers 3000mm	1685	1840	4690

Adjust anchor bolts to make them be loaded evenly. Level the lathe by the precision leveler and tighten anchor bolts, then recheck the horizontal accuracy of the bed by the precision leveler.

3-10 Lubrication Examination

In order to ensure good lubrication in the headstock and the feed box of the lathe, fill 20 liters of L-FC15 bearing oil (or MOBIL Velocite10) into the oil tank in the front leg of the lathe and adjust the oil level; fill L-HM68 (or OBIL D.T.E.26) wear resisting hydraulic oil into the carriage apron and make its level no over the oil window.

Before each shift, fill oil in the saddle, the cross slide and the bed tail by the oil gun.

See the lubrication part in the maintenance section of the manual.

3-11 Spindle Bearings of the Headstock

Though all bearings of the headstock have been adjusted and tested before leaving the factory, it is suggested to make further commissioning of the bearings of the headstock before long-term operation at high speed.

Suggested time of speed of commissioning:

Run for 1 hour at 15% of the highest speed;

Run for 30 min at 30% of the highest speed;

Run for 30 min at 80% of the highest speed.

3-12 Cleaning

Before operating the lathe, clean anti-rust oil on rails, leading screw, feed bar, taper hole of the spindle and sleeve of the bed tail by kerosene.

Do not use unauthorized solvent, cellulose solvent or gasoline as they are dangerous and can damage paintings.

After cleaning, all smooth and processed surfaces should be oiled.

3-13 Leveling

Make leveling by the precision leveler (0.05mm/m) mounted on the cross slide. Make leveling of the lathe by adjusting relative anchor bolts from one end to the other and from the rear part to the front part. The longitudinal and lateral leveling should be done as per stipulations on the Item G1 in <Conformity Certificate> of the lathe so as to avoid torsion.

4. Power Supply and Connection

Input Voltage

The power supply is three-phase 380 V \pm 10%, 50 Hz, and the lathe with power supply of 220 V, 60 Hz is also available.

The recommended fuse is 25 A (380 V).

Power supply introduced to each lathe should run through an external distribution cabinet equipped with independent fuse, from which wires shall be led into the electrical cabinet of the machine and connected with terminals inside the cabinet. The grounding wire should be also connected.

The correct rotation direction of the main motor can be defined as follows: set the left/right screw handle on the headstock at the position of the right screw and lift up the start bar (10) (see the operation system drawing), the spindle should rotate towards normal positive direction. If the rotation direction of the spindle is wrong, it should switch off the main power supply, exchange any wires from two phases in three-phase wires introduced into the electric cabinet. The electric schematic drawing, components arrangement drawing, list of components and wiring diagram are all in the Service Atlas of the Lathe.

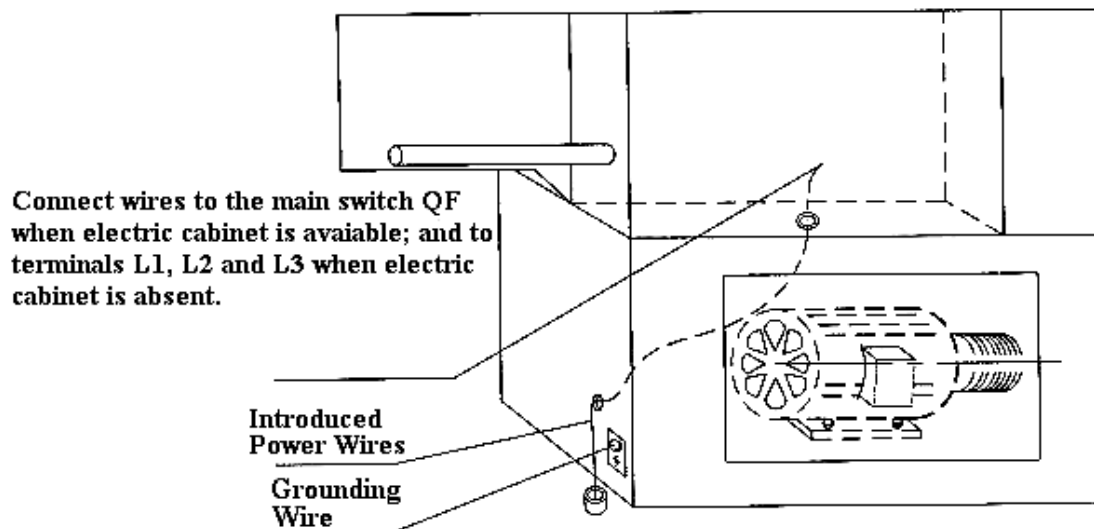

Wiring Diagram

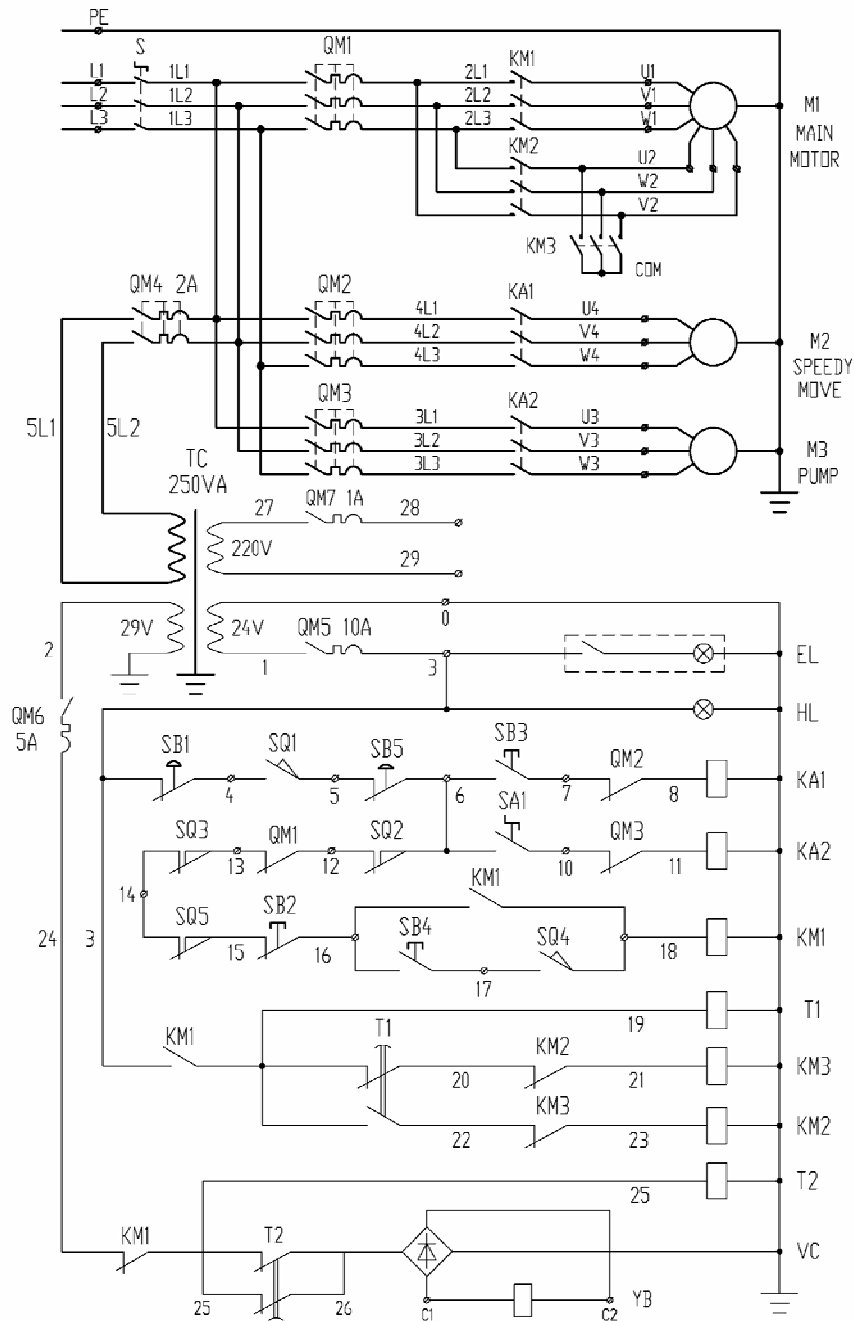

C6266-12K1

Electrical Listing Component

No	Type	Name	Specification	Qty	Manufacturer
1	S	Main Switch	LW8GS-40(63)/3000-A	1	WuXi Wirelesn Nine Factory
2	QM1	Breakers for Main Motor	GV2-M 13-18A(415V.440V7.5KW)	1	Schneider
			GV2-M 17-23A(380V.400V7.5KW)		
			GV2-M 20-25A(415V.440V11KW)		
			GV2-M 24-32A(220V7.5KW)		
			GV2-M 24-32A(380V400V11KW)		
			DZS7-63 36-52A(220V11KW)		WuXi Wirelesn Nine Factory
3	QM2	Breakers for Speedy Move Motor	GV2-M 1-1.6A(1.6-2.5A)	1	Schneider
4	QM3	Breakers for Coolant Pump	GV2-M 0.25-0.4A(0.4-0.63A)	1	Schneider
5	QM4	Breakers	□SMC32N2C2	1	Schneider
6	QM5	Breakers	□SMC32NIC10	1	Schneider
7	QM6	Breakers	□SMC32NIC5	1	Schneider
8	QM7	Breakers	□SMC32NIC1	1	Schneider
9	KM1.KM2	AC Contactor	LC1-2501 24V50/60Hz	3	Schneider
10	KA1.KA2	Relay	CA2-DN140 24V50/60Hz	2	Schneider
11	TC	Control Transformers	JBK5-250/24V29V220V	1	WuXi FuJie Ele.Appliances Co. Ltd
12	SA1	Coolant Pump Selection	XB2ED21C	1	Schneider
13	SB1.SB5	Emergency Button	XB2ES542C	2	Schneider
14	SB2	Stop Button	XB2EA142	1	Schneider
15	SB3	Speedy Move Button	XB2EA131	1	Schneider
16	SB4	Stat Button	XB2EA131	1	Schneider
17	HL	Pilot Lamp	XB2BVB3C AC24V	1	Schneider
18	EL	Working Lamp	JC38C 24V50W	1	NanTong JinXing Machine wiring Factory
19	SQ1	Switch for Position	QKS8 250V12A No:6080103201	1	YueQing Puqi Ele Plastic Factory
20	SQ2	Switch for Brake	TZ6002 15A250V	1	HangZhou LiDe Motor Co. Ltd
21	SQ3	Switch for Chuck	LXW5-11Q1	1	ShangHai Secondly Machine Tool Co. Ltd
22	SQ4	Switch Position	LXW5-11Q1	1	ShangHai Secondly Machine Tool Co. Ltd
23	SQ5	Switch for Knife rest	QKS7-5 (2NC)	1	YueQing Puqi Ele Plastic Factory
24	T1.T2	Time Relay	REXL2TMB7 AC24V	2	Schneider
25	VC	Rectifier	3TQL 250V12A	1	WuXi Wirelesn Nine Factory
26	YB	Motor Detent (M1)	80(150)Nm DC24V60(90)W	1	ShangHai Cema Motor Factory
27	M1	Main Motor	Y132(160)M-4 7.5(11)KW	1	ShangHai Cema Motor Factory
28	M2	Coolant Pump	AYB-25G	1	ShangHai PuJiang Motor Factory

1.All Accord Component CE Criterion

C6266-12K1

2.Specification in Bracet Shoncd be used for AC220V

5. Chuck and its Installation

When mounting the chuck and the surface plate, first of all to ensure clean of the spindle and the taper part of the chuck.

For the spindle which is locked by D-type cam, it should ensure that the cam is locked at right position. When the new chuck is mounted, it should readjust the lock bolt (A) of the chuck. Therefore it should remove the lock screw (B) first, adjust each lock bolt in turn to make the engraved lines on them be flush on the rear end surface of the chuck, and make the round sector be identical with the hole of the lock screw. Then mount the lock screw (B) and mount the chuck on the spindle, lock six cams on the spindle head in turn.

The correct lock position of the cam should make the locking engraved line on each cam lies between two V letters on the spindle head. If the cam is not locked at this position, it should dismount the chuck or the surface plate and make adjustment again as per procedures mentioned above.

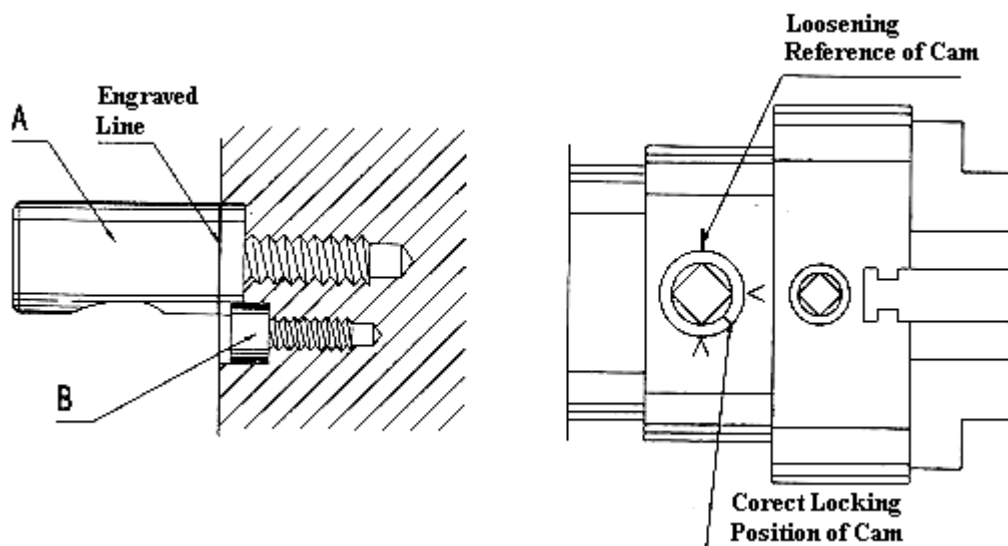

Warning

When adopting the four-jaw chuck and the surface plate, be sure to take care of the limit of the speed of the spindle. For the four-jaw chuck with $\phi 315$ mm, the speed of the spindle should be no larger than 850 r/min; for the surface plate with $\phi 350$ mm, the speed of the spindle should be no larger than 550 r/min.

For the surface plate with $\phi 450$ mm used by the saddle lathe, the speed of the spindle should be no larger than 500 r/min.

(Subject to the data specified on the signboard of the lathe).

When the steel-made three-jaw chuck is used, the speed of the spindle of new three-jaw chuck with $\phi 250$ mm should be no larger than 2500 r/min, and that of old

three-jaw chuck with $\phi 250$ mm should be no larger than 1600 r/min.

The chuck with defects such as crack etc. is not allowed to use on the lathe.

The steel plate three-jaw chuck is recommended.

6. Safe Operation of the Lathe

Safe Regulations of the Lathe

Before starting the lathe, read the operation instruction on the manual carefully.

For the sake of safety, please read the guidance of safe operation at the beginning of the manual.

Key points are as follows:

1. Ensure to master the way to stop the machine before starting it.
2. Stop operation of the lathe immediately in case any accident occurs.
3. Ensure cutting speed, feed and cutting depth to be suitable with the processed parts and the jigger.
4. When the spindle is rotating, do not contact the tool, the chuck and the workpiece.
5. Wear and use suitable protective articles and devices.

7. Operation System

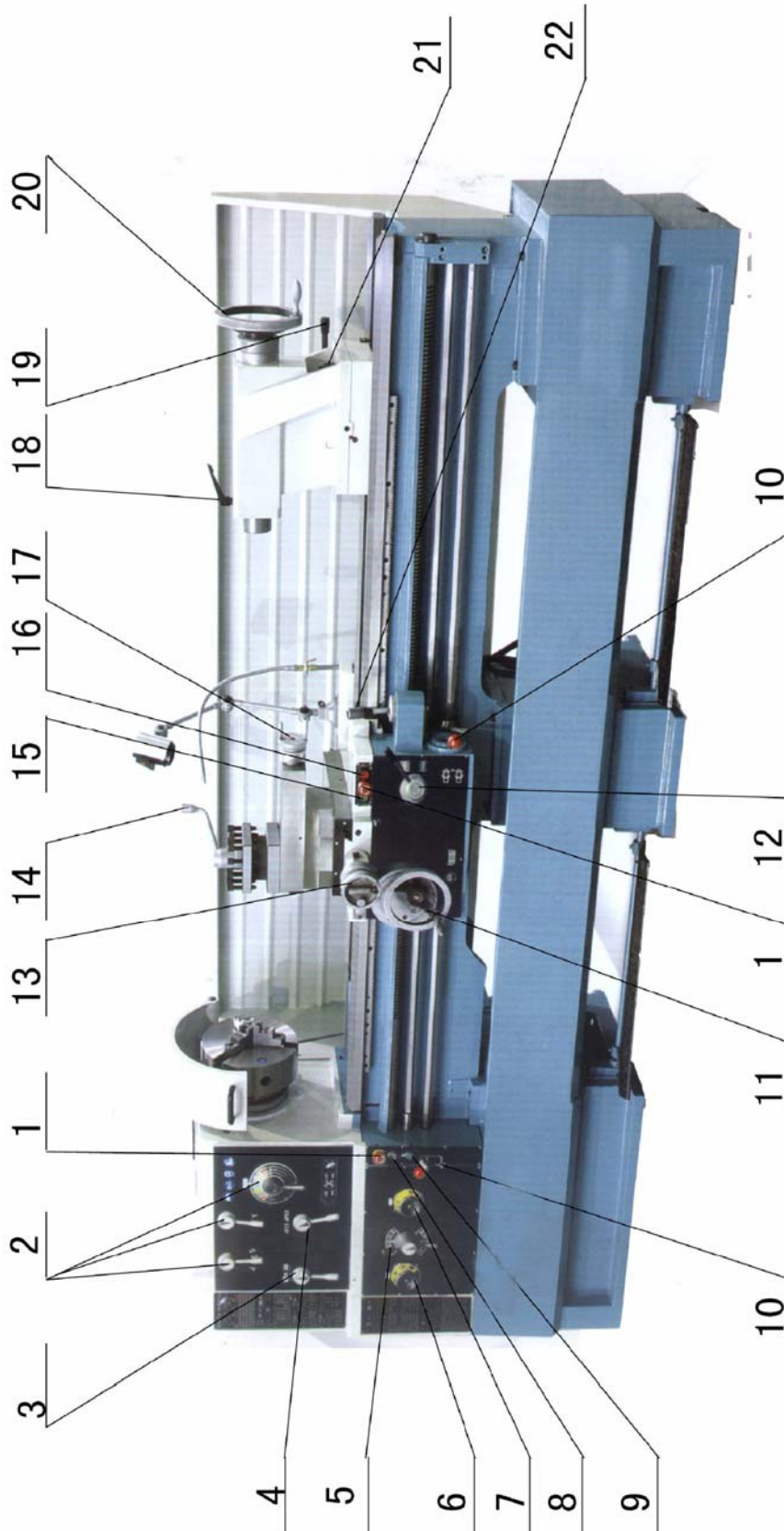

1. Emergency Stop Button
2. Selection Handles of Spindle Speed
3. Left/Right Screw Handles
4. Pitch Extension Handle
5. Feed Basic Handle
6. Screw Selection Handle
7. Double Feed Handle
8. Cooling Pump Switch
9. Power Supply Lamp
10. Spindle Clutch Handle
11. Apron Longitudinal Hand-Wheel
Button
12. Open/Close Nut Handle
13. Lateral Hand Wheel
14. Tool Holder Lock Handle
15. Main Motor Start Handle
16. Main Motor Stop Handle
17. Small Tool Holder Handle
18. Tail Sleeve Lock Handle
19. Tail Fast Lock Handle
20. Tail Hand Wheel
21. Tail Extra Lock Nut
22. Tool Holder Longitudinal/Lateral
Selection Cross Handle and Fast

7-1 Meaning and Function of Operation Signs

	_____	Turn Leftward		Right Feed
	_____	Turn Rightward		Left Feed
1/1	_____	Basic Pitch/Basic Feed		
8/1	_____	Extended Pitch (8 folds)		
	_____	Switch of Cooling Pump		
	_____	Indication of Power Supply		
mm	_____	Metric Thread		
m π	_____	Module Thread		
1/in	_____	Inch Thread		
π/in	_____	Pitch Thread		
x mm/°	_____	Longitudinal Feed of Spindle per Rotation		
x mm/°	_____	Lateral Feed of Spindle per Rotation		
	_____	Turning Thread		
	_____	Tool Feeding		
	_____	Open/Close Nut Opening		
	_____	Open/Close Nut Closing		

7-2 Electric Control

The main switch of power supply of the lathe is located at the rear of the lathe. When it is switched on, the lamp of power supply (9) lights. There is the interlocked switch inside the side cover to switch off power supply when the door is opened.

The control of the main motor is in front of the saddle to control start and stop of the main motor. When the start button (15) is pressed down, the main motor starts to rotate. When the stop button (16) or the emergency stop button (1) is pressed down, the main motor stops running.

The control button of the fast-moving motor of the carriage apron is located at the top of the handle (21) on the carriage apron box to control start and stop of the fast-moving motor of the apron.

The control (8) of the cooling pump motor is in front of the feeding box to control start and stop of the cooling pump motor.

7-3 Turning and Braking of the Spindle

The control of the main motor is located in the front of the saddle to control start and stop of the main motor. When it is pressed down, the main motor starts to rotate. Lift up the handle (10) of the clutch, the positive-turning clutch of the spindle is engaged and the spindle rotates positively while the handle (10) is pressed down, the negative-turning clutch of the spindle is engaged and the spindle rotates negatively. When the handle of the clutch of the spindle is in the middle, the clutch of the spindle is disengaged and the spindle is braked by the brake belt in the headstock and the lever.

7-4 Speed of the Spindle

16 kinds of speed of the spindle can be obtained by selecting position of the handle (2) on the headstock.

Warning: The spindle system is not allowed to change speed in motion.

7-5 Selection of Pitch and Feed

Under normal condition, selection of kinds of thread can be achieved without changing the change gear no matter for metric thread, inch thread, module thread or pitch thread. All obtained pitch and feed are given on the signboard of the feeding box. The pitch obtained from the extension pitch is generally 8-folds of the normal one. Take care that the extension pitch can only be achieved when the speed handle of the spindle is on position and corresponding speeds of the spindle are 70, 50, 35 and 25 r/min.

In case the speed handle of the spindle is on position (X, H), no extension pitch can be achieved.

Warning: When the spindle is rotating at high speed, no extension pitch can be selected, and the change gear shall be equipped as per the schematic drawing on the signboard.

For those threads not listed on the signboard and our manual, please contact with the technical department of our company.

When the double feed handle on the feeding box is at positions V-VIII, the thread function can be achieved.

When the double feed handle on the feeding box is at positions I-IV, the tool feeding function can be achieved.

7-6 Positive/Negative Direction of the Leading Screw

The handle (3) of the headstock can change turning direction of the leading screw and the smooth bar thus to achieve transfer of left/right threads.

Processing way of the first thread: by means of small tool holder to move forward one pitch each time at the beginning to process multiple threads. At this time the tool holder has a 90° angle with the axial line of the cross slide; by means of a driving plate with graduations, turn the workpiece one graduation each time before processing to process multiple threads; mount the pad with the thickness identical with the pitch of thread on the chuck to process multiple threads.

7-7 Control of the Slide of the Saddle

By means of longitudinal and lateral hand wheels (11) and (13) to operate the small tool holder, or make feeding by the cross handle (21).

Normally set the left/right thread handle on the headstock at the position of eth right thread. At this time the direction of the cross handle is just the direction of feeding of the tool holder. If pressing down the button on the end of the cross handle the tool holder can move fast.

When the open/close nut handle on the carriage apron is opened, above processing can then be carried out. The open/close nut is interlocked with the tool feeding.

7-8 Operation of Feed Box

There three sets of handle on the feed box: (5), (6) and (7).

The handle (6) is used to select types of thread. Four kinds of thread are available: metric, incj, module and pitch threads.

The handle (5) is a double-handle A and B in basic group.

The handle (7) is a double feed one. When it is at positions of I, II, III and IV, the smooth bar can rotate while when it is at positions V, VI, VII and VIII, the leading screw can rotate.

Under normal condition, selection of kinds of thread can be achieved without changing the change gear no matter for metric thread, inch thread, module thread or

pitch thread.

7-9 Operation of the Carriage Apron

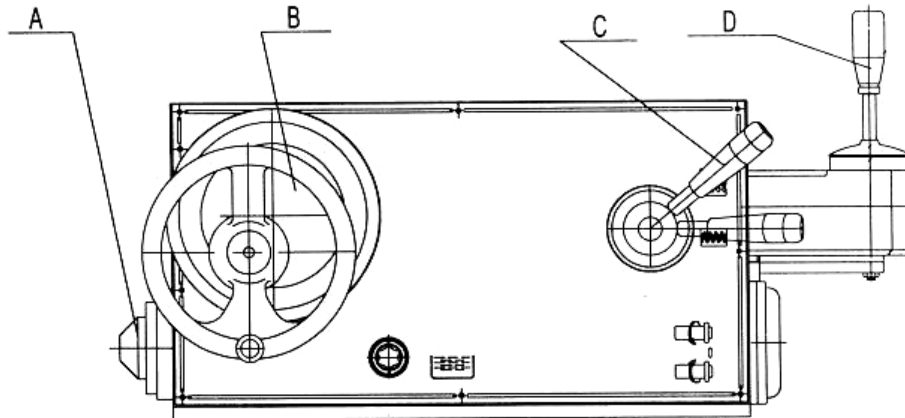

- A. Safe Clutch with Overload Protection
- B. Carriage Apron Hand Wheel
- C. Open/Close Nut Handle
- D. Cross Handle

7-10 Adjustment of Feed Safety Device

In the left flange of the carriage apron there is a set of safe clutch for overload protection of feed. When the feeding force of the tool holder is over the set load, the safe clutch shall slip to stop feed of the tool holder. The size of the load to be transmitted depends on the pressure of the spring and is adjusted well when it leaves the factory. The customer can adjust it as required. When adjusting, remove the cover plate E on the left end of the carriage apron and make the spindle of the lathe run at a lower speed, adjust the screw F by the spanner to adjust the pressure of the spring G thus to adjust the load transmitted by the overload protection mechanism. In case the feeding force is over the set load, the clutch H slips in the internal taper sleeve J and the motion transmitted by the smooth bar is stopped at the clutch H and the internal taper sleeve J.

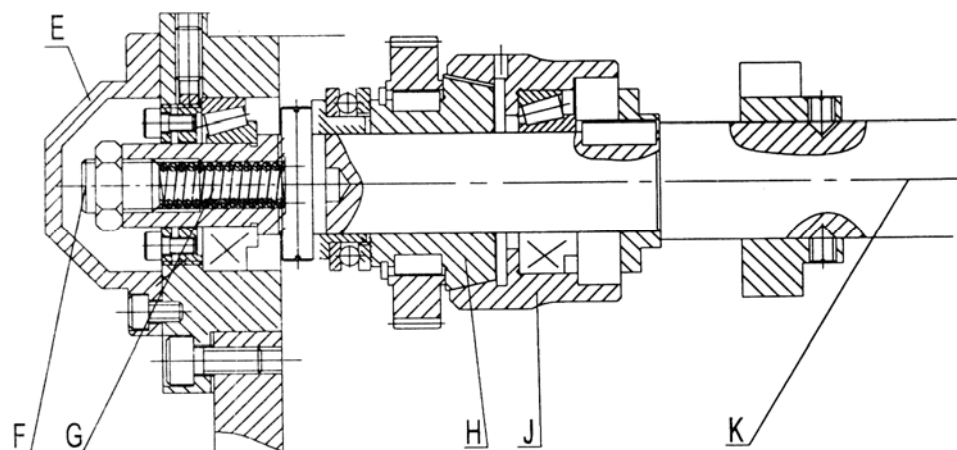

7-11 Carriage Apron Hand Wheel

By means of the cross handle to make the saddle feed longitudinally or to move fast, the carriage apron hand wheel shall disengaged automatically and stop rotation. Only the cross handle is at the central position can the carriage apron hand wheel make the saddle move longitudinally.

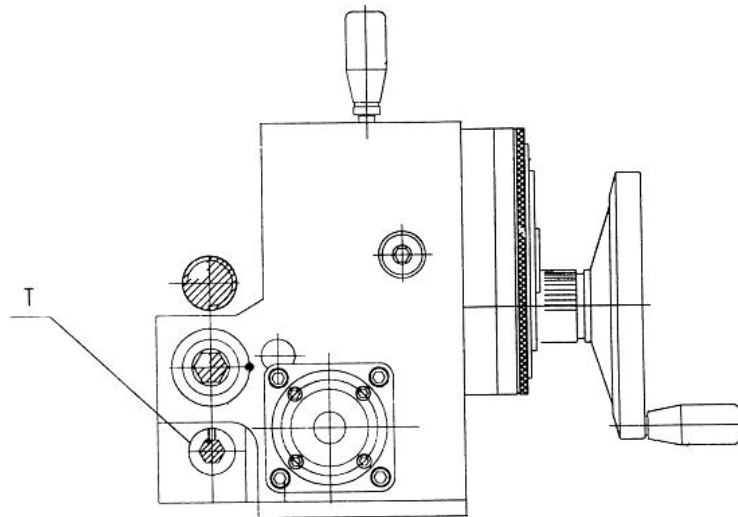

7-12 Longitudinal Stop Iron of the Carriage Apron

The longitudinal stop iron T is set at the start bar of the lathe on the left side of the carriage apron. The lock screw on it can make the carriage apron stop longitudinally and automatically at required position so as to carry out single-way fixed-travel turning.

7-13 Locking of the Saddle

The lock screw of the saddle can lock the saddle tightly on the rail of the saddle to prevent its motion along the direction of the bed.

7-14 Cooling

The operation of the cooling pump is controlled by means of the switch of the cooling pump on the feed box.

The cooling fluid flows out from the vertical pipe and the hose.

The cooling liquid box is located at the middle leg of the lathe with the volume of 32 liters. Any kind of industrial cooling liquid can be used.

7-15 Tailstock

The lock handle (19) can make the tailstock be locked on the rail of the bed rapidly

and is used on finish turning and semi-finish turning to prevent the tailstock to move along the direction of the bed. When making rough turning or other large load cutting, the lock screw of the tailstock (24) should be also locked. The lock handle of the tail sleeve (18) is used to lock the tail sleeve. When using the tailstock to process taper part, both screws (C) at both sides of the tailstock should be also adjusted to make the tailstock move laterally to the required distance, then lock the handle (19) and screws (C).

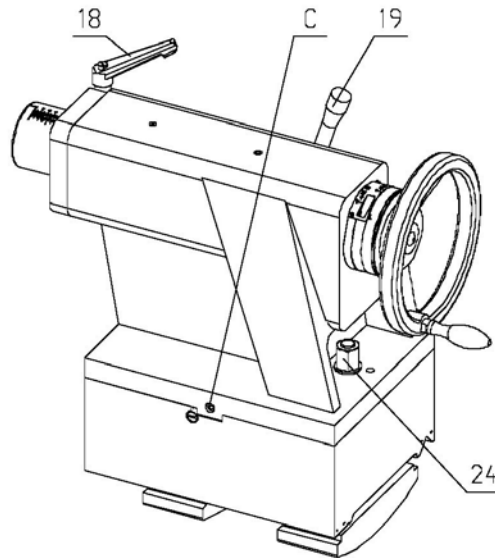

7-16 Mounting/Dismounting of the Saddle

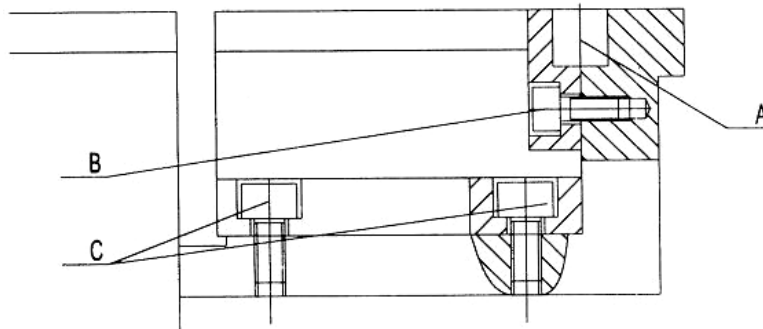

Steps to Dismount the Saddle

1. Clean the periphery of the saddle;
2. Remove the fixing pin A;
3. Remove the screw B;
4. Remove the screw C;
5. Remove the protective cover of the leading screw;
6. Dismount the saddle.

Steps to Remount the Saddle:

1. Clean the joint faces of the saddle and ensure their cleanness;
2. Ensure the bed of the lathe to be on qualified level status;
3. Gently move the saddle to the position to be mounted;
4. Put on the screw B and the cylindrical pin A and make adjustment by the rubber hammer.
5. Tighten screws C and B.

8. Maintenance

8-1 Accuracy of the Lathe

Before the formal operation of the lathe after it is installed, it is necessary to make examination upon the accuracy of the lathe. During the course of operation, check the accuracy of the lathe regularly so as to ensure the accuracy of the lathe for a long term.

8-2 Check the Headstock

After examination of the accuracy of the lathe, it is suggested to check the accuracy of the headstock. Jig a steel bar with the diameter of 50 mm and the length longer than 150 mm on the chuck without finish turning the excircle, the cylindricity should be within 0.01 mm in the length of 100 mm.

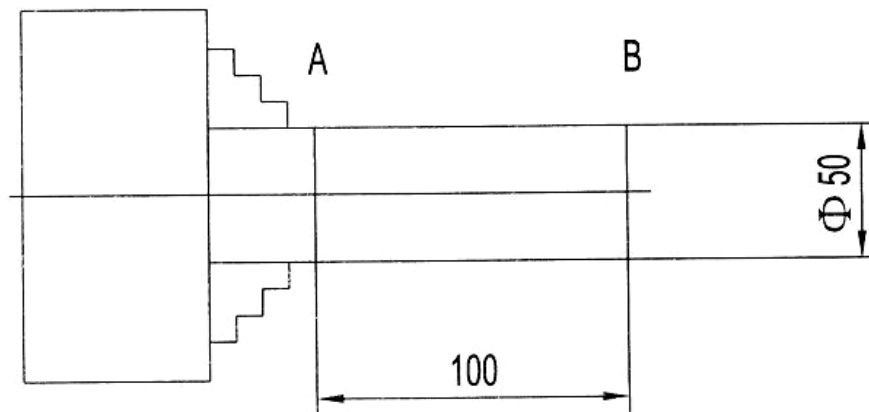

8-3 Check the Tailstock

Place a ground steel axle with the length of 300 mm, check the accuracy of the tailstock by moving the micrometer gage along the central line. Adjust the accuracy of the tailstock as per the way to adjust the screw (C) of the tailstock.

8-4 Adjustment of the Driving Belt

Switch off power supply to check the tension force of V-belt. Press the point D on each V-belt by hand. Loosen two lock nuts C on the bolt B to adjust the tension then tighten both top and bottom lock nuts in turn.

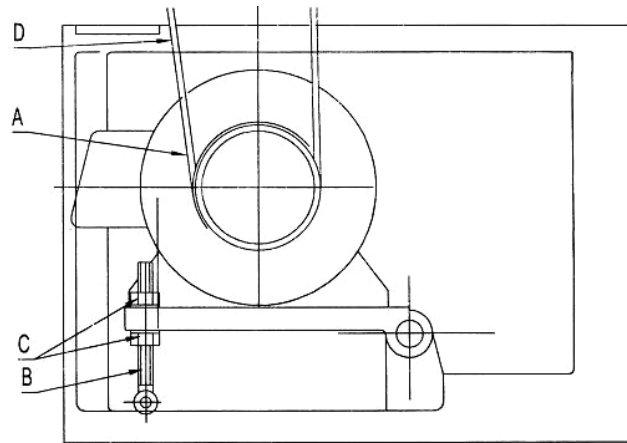

8-5 Adjust the Clutch of the Tailstock

The headstock has two lamella clutches to transfer torques of positive and negative rotation of the spindle respectively. For the lathe equipped with the standard chuck, if the start time from stop to high speed is over 4 seconds, the clutch should be adjusted as follows:

1. Switch off powers supply of the lathe;
2. Set the spindle at the neutral position - - - "O " ;
3. Open the cover of the spindle box;
4. Press down the lock pin E to press the spring, turn the nut G to adjust pressure of the friction disc H;
5. Reset the lock pin to one notch of the nut G and close the cover of the box.

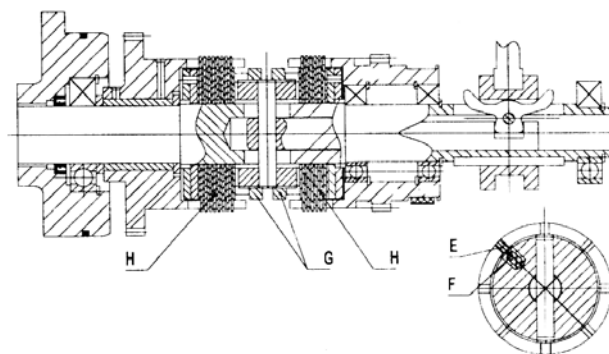

If the overshoot occurs, the clutch shall be overheated and damaged.

8-6 Adjustment of the Brake of the Headstock

There is a friction brake in the headstock at the transition position of both positive and negative rotations. During the course of operation, if the brake time from high

speed to stop is over 8 seconds, the brake is required to make adjustment as follows:

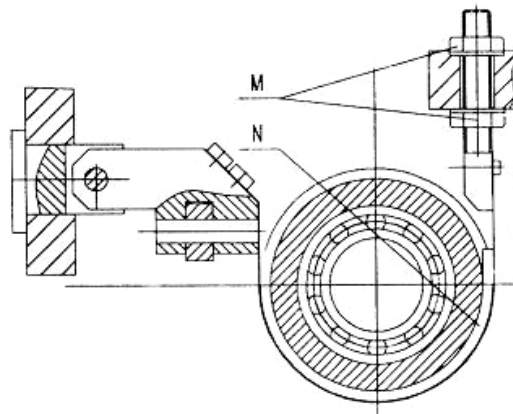

1. First of all, switch off the main power supply of the lathe, then set the high/low speed handle of the spindle to the neutral position and set the start bar at the middle position;
2. Open the cover of the spindle box;
3. Adjust pressure of the brake belt N by means of the adjusting nut M to the suitable position where other axles shall not rotate when turning the axle of the pulley;
4. Close and reset the cover of the box.

8-7 Gib of the Rail

There are the wedge gibs on the cross slide and the small tool holder to compensate wearing. When adjusting, first of all loosen the rear gib screw D then tighten the front gib screw, at last tighten the rear gib screw. Only a bit adjustment could be done each time. Before the gibs are adjusted, clean and lubricate gibs so as to keep smooth operation.

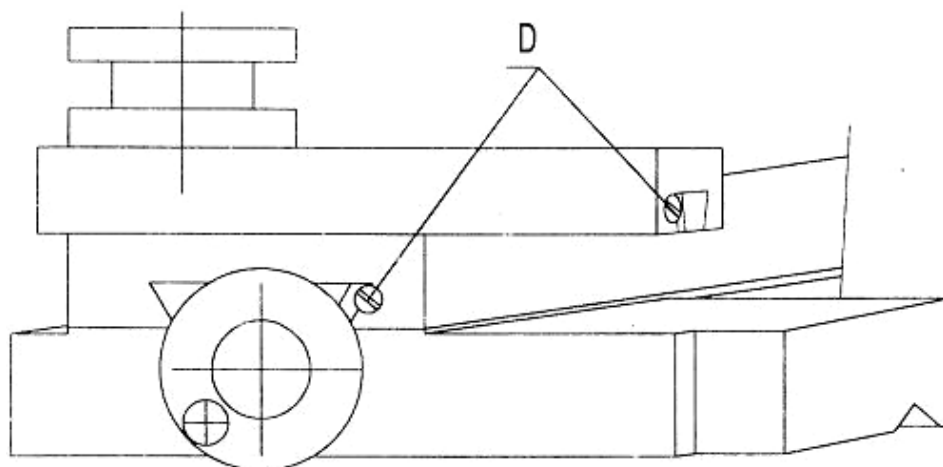

8-8 Adjustment of Cross Leading Screw Nut

As the friction between the leading screw and the nut can cause worn-out of the nut and make the free stroke of the lateral graduation ring too large. At this time you should adjust the clearance between the leading screw and the nut. Loosen the top screw 1 and suitably tighten the screw 2, then tighten the top screw 1 if the clearance is considered suitable.

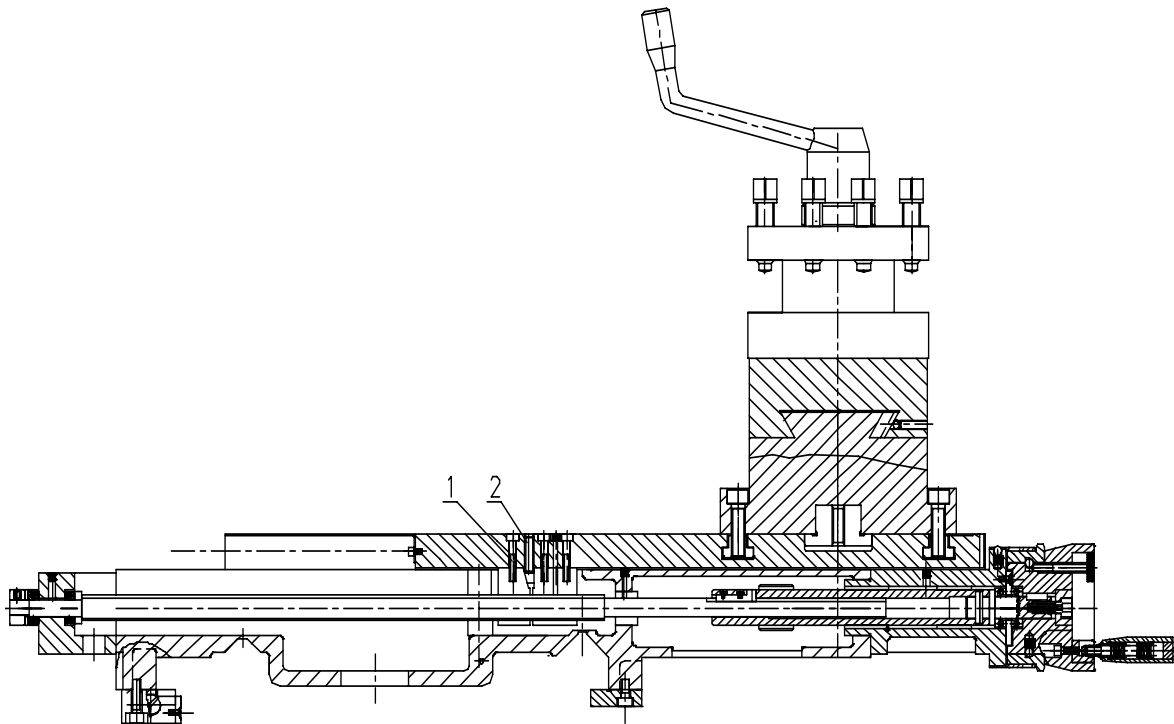

8-9 The Change Gear

The change gear of the lathe is need not to be replaced under normal condition to make turning and processing of various kinds of screws. It should be replaced only when special thread is processed.

When processing 11 1/2 and 19 inch thread, the change gear should be replaced.

When processing metric thread with pitch larger than 80 mm or special pitch, the change gear should be changed.

The change gear which takes feeding function is the same with that taking normal pitch.

9. Lubrication

9-1 The Headstock

The continuous lubrication of the spindle bearings, headstock gears and all axles are made and distributed by the oil pump and the oil distributor in the headstock. The oil pump is the cycloid lubrication pump and is driven by the axle I in the headstock. The speed of the oil pump is in no relation with that of the spindle. The oil window is located on the right side of the headstock for check oil supply

Note: Only the oil is seen to flow out can the lathe be started.

9-2 Feeding Box

The return oil of the headstock is used to lubricate gears and bearings in the feeding box, then returns to the oil tank via the return pipe.

9-3 Oil Tank

The oil tank is inside the front leg of the lathe with volume of 13.5 liters. Fill L - FC15 bearing oil (or Mobil Velocite 10/ESSO Spinesso 15) into the oil tank.

9-4 Carriage Apron

The oil bath lubrication of the gears and bearings of the carriage apron are made by means of spraying style. The oil window is in front of the apron and the oil drain hole is at the bottom of the apron. The lubrication oil is: L-HM68 or L-HM46, MOBIL DTE 26.

9-5 Change Gear

The change gear is lubricated by the oil distributor in the headstock.

9-6 Indication of Lubrication of the Lathe

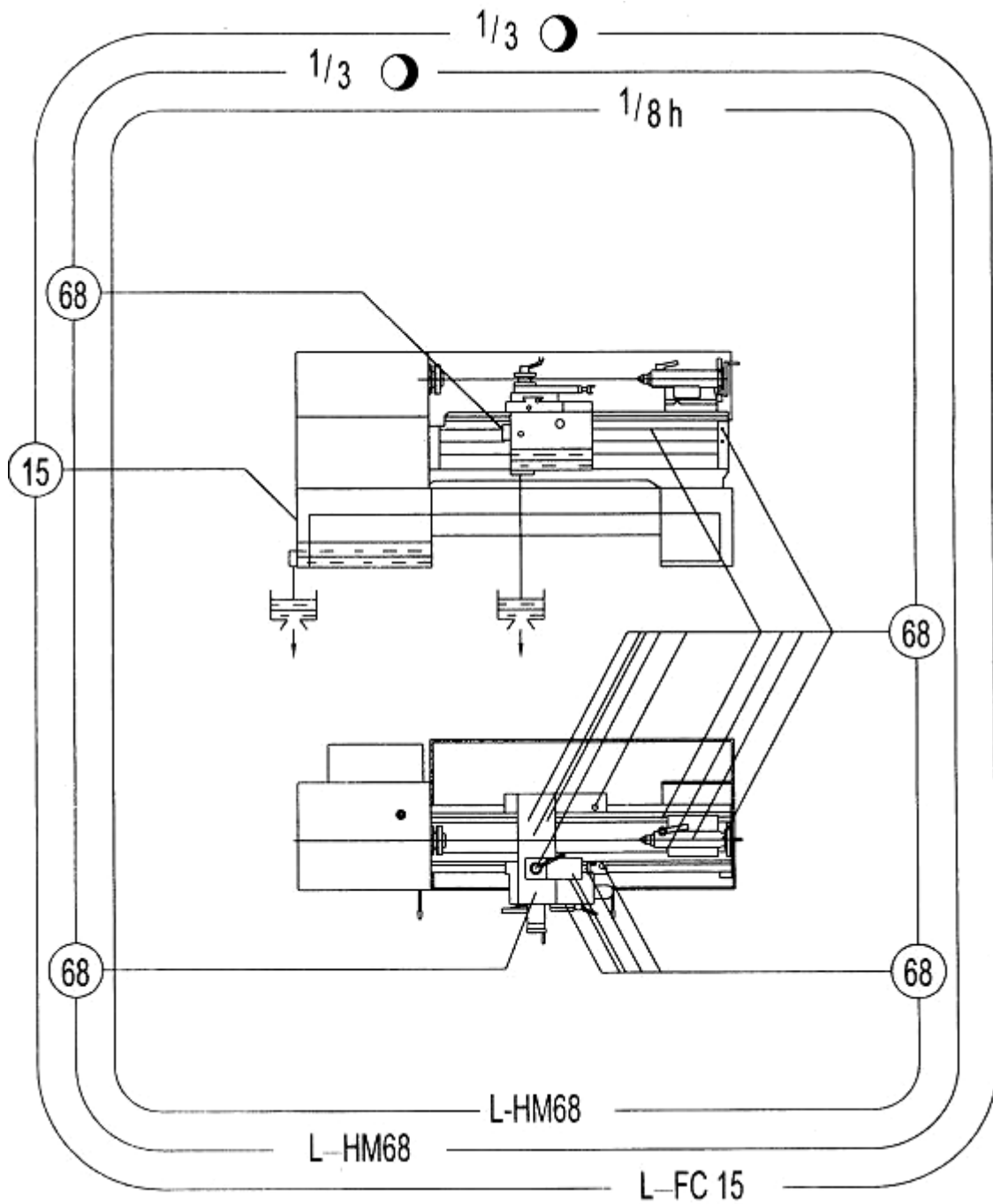

Fill L-FC15 bearing oil of 13.5 liters into the oil tank once every three months.

Fill L-HM68 hydraulic oil about 1.5 liter into the carriage apron and the cross slide once every three months.

Fill L-HM68 hydraulic oil on all rails, leading screw, tail and tool holder once every shift.

10. Normal Troubles and Remedies

S/N	Normal Trouble	Causes	Remedies
1	Higher temperature rising of the spindle bearings. The max. temperature over 70°C or temperature rising over 40°C.	<ol style="list-style-type: none"> 1. The brand of lubricating oil is not right.; 2. Lubrication oil is not suitable (much or less); 3. Clearance of the spindle bearing is too small. 	<ol style="list-style-type: none"> 1. Fill suitable lubricating oil in the spindle bearings; 2. Replace with lubricating oil of right brand; 3. Readjust clearance of the spindle bearings.
2	The clutch in the headstock is heating and temperature is higher.	<ol style="list-style-type: none"> 1. Bad lubrication or oil couldn't be supplied; 2. Too small clearance of the clutch; 3. Large clearance at the pin roll of the pull rod of the clutch and the actual operation stroke of the friction disc is affected. 	<ol style="list-style-type: none"> 1. Check oil supply of the oil pipe in the headstock; 2. Adjust clearance of the clutch in the headstock; 3. Check all pin rolls of the pull rod of the clutch, and replace them if worn out or deformed largely.
3	In operation of the lathe, after the cross handle at the right side of the apron is closed, the toll holder has no feed or only has motion in one direction.	The left/right handle in front of the headstock is in the middle position.	When the spindle rotates positively the left/right handle points rotation rightward while the spindle rotates negatively the left/right handle points rotation leftward. No such a limit when turning thread, which is in relation to thread direction of the workpiece.

S/N	Normal Trouble	Causes	Remedies
4	The spindle vibrates in course of turning.	Clearance of the front bearings of the spindle is too large.	Readjust the front bearings of the spindle and reduce clearance of bearings.
5	No oil in the oil window of the tailstock after the main motor is started.	<ol style="list-style-type: none"> 1. Too lower of oil temperature; 2. No suction of lubrication oil pump due to leak of pipe; 3. Filtering screen is blocked and no oil is sucked; 4. Gas leak from large gap due to worn-out on end face of rotor of the oil pump or between the axle and the sleeve. 	<ol style="list-style-type: none"> 1. Check ambient temperature and oil temperature in winter and the oil pump couldn't work if temperature is too low; 2. Check tightness of the oil pump and pipe connection by dry tallow, make good sealing if gas leak occurs; 3. Remove the oil tank and clean or replace the filtering screen; 4. Repair or replace the oil pump. 5. Fill enough lubrication oil in the oil tank.
6	The lock position of small tool holder is not fixed.	The positioning part of the small tool holder is blocked.	Fill lubrication oil in the positioning part of the small tool holder.

11. Parts List Assembly

Headstock

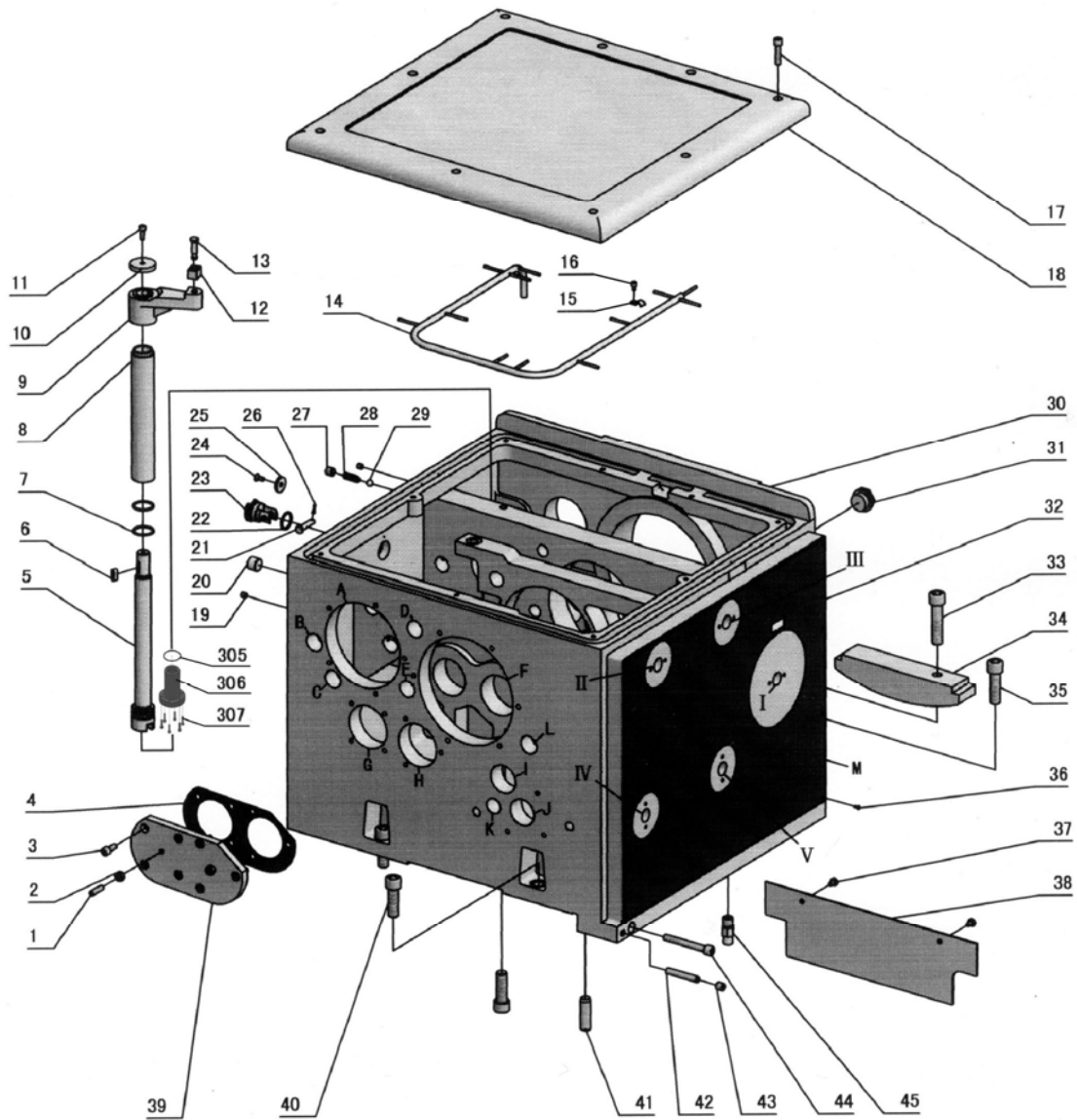

A

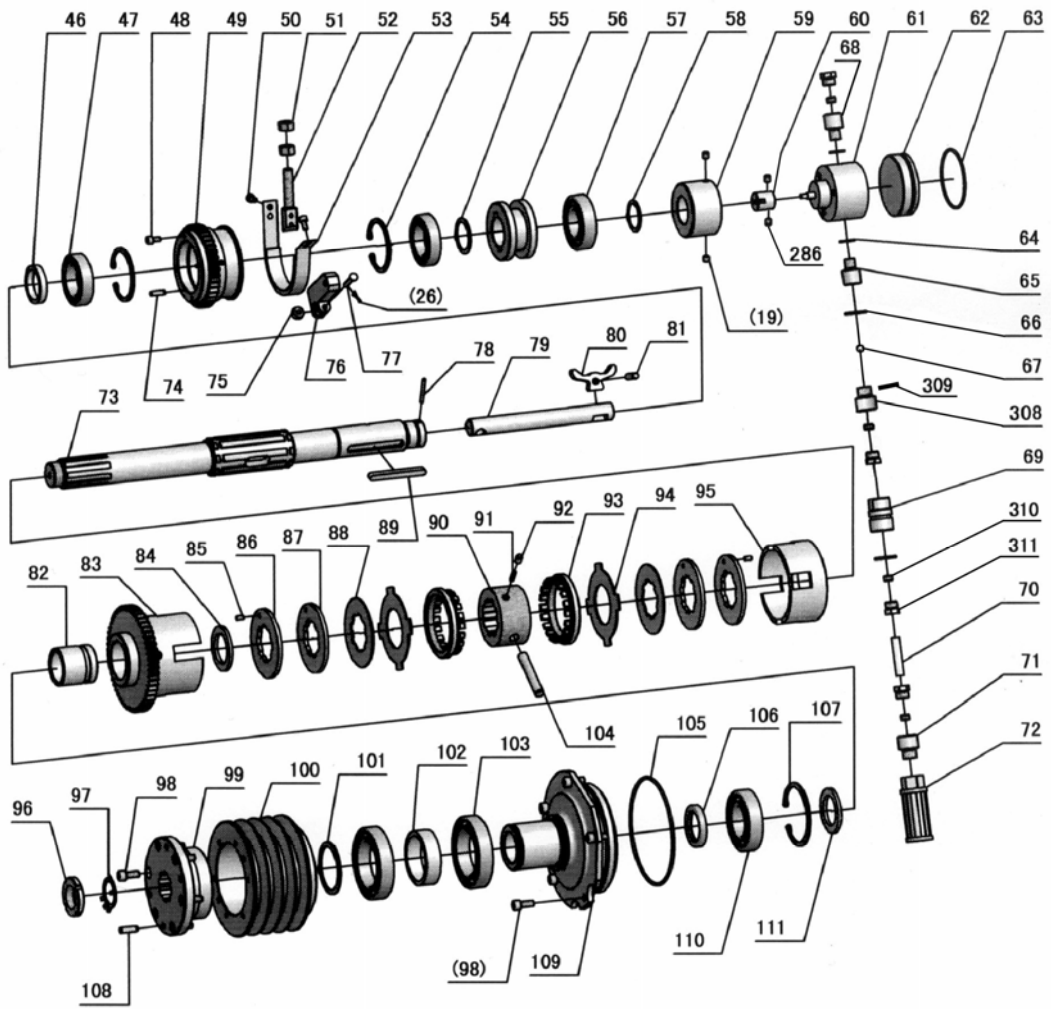

B

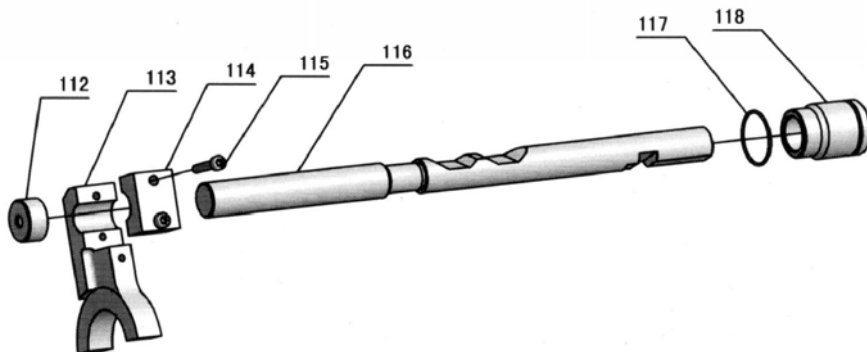

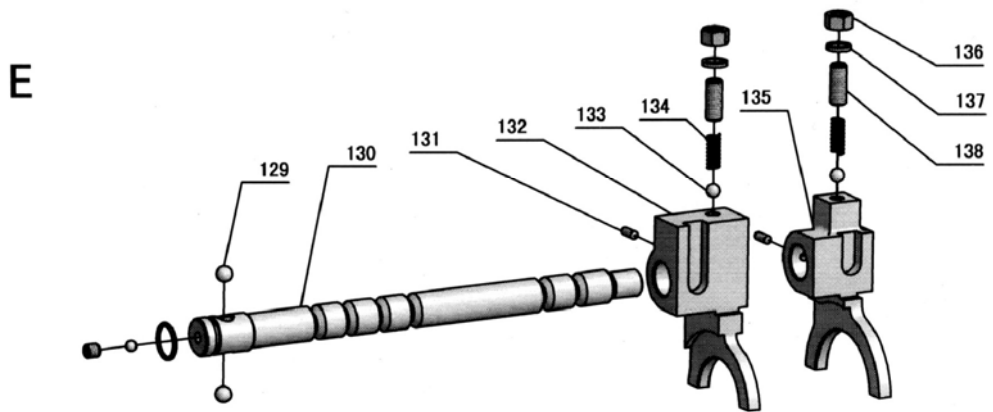
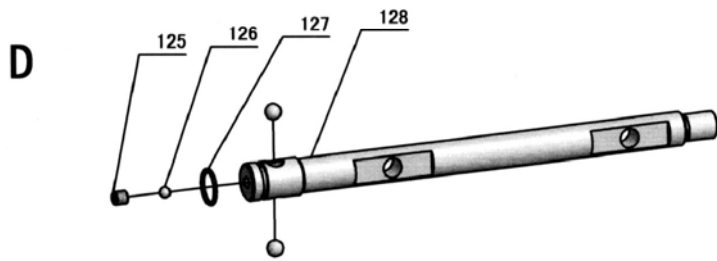
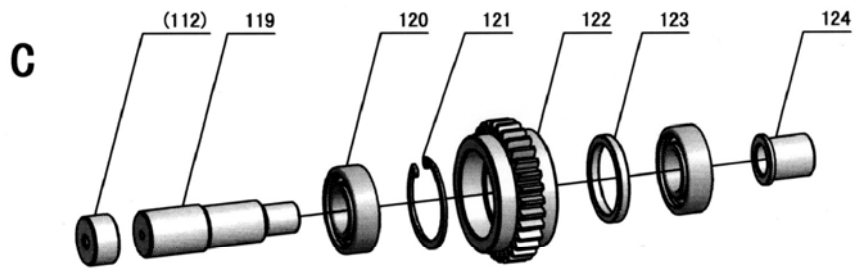

F

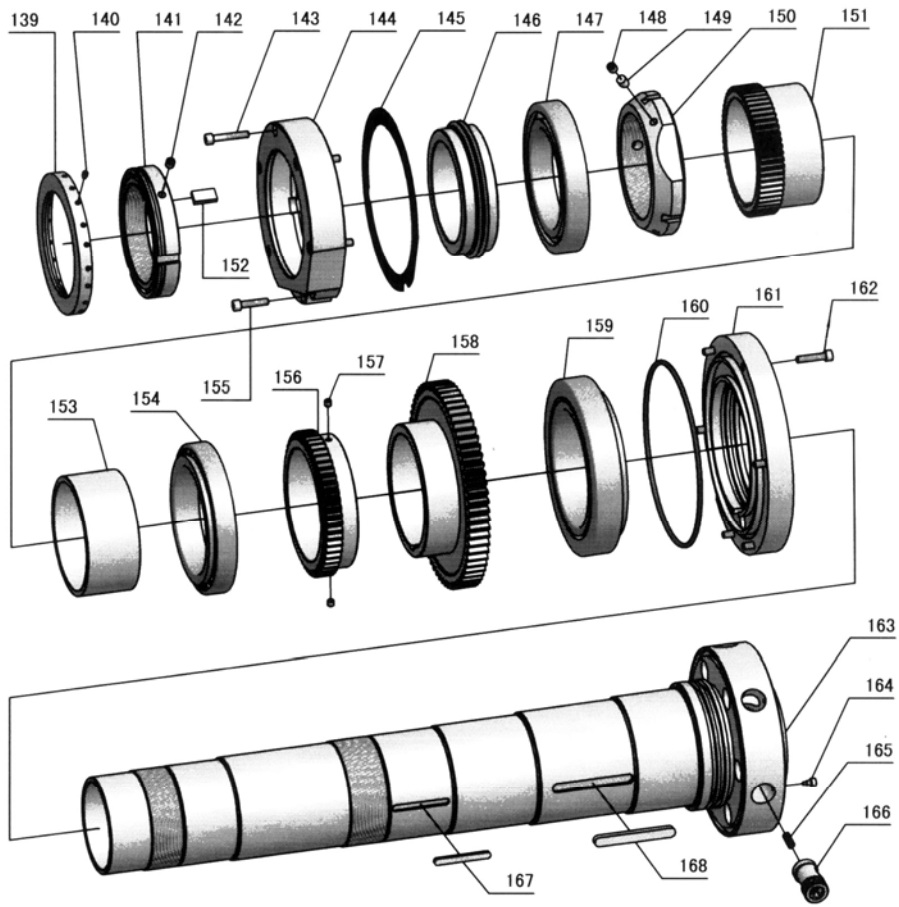

G

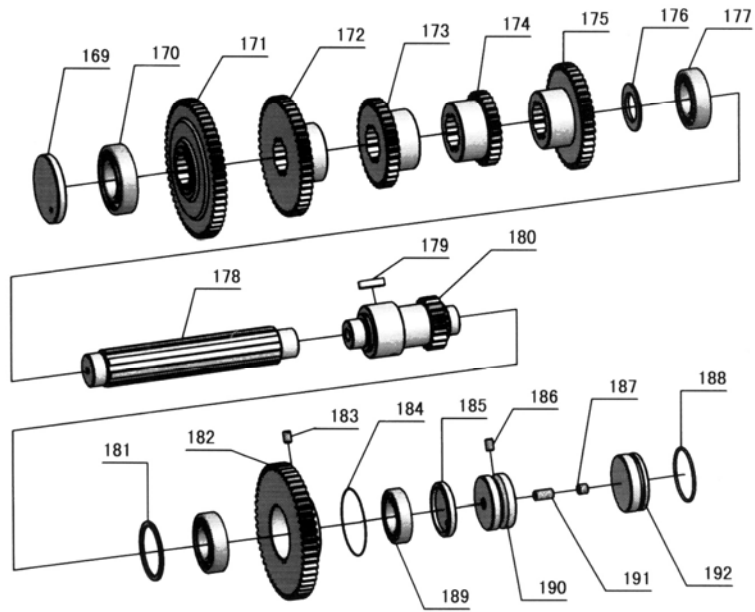

H

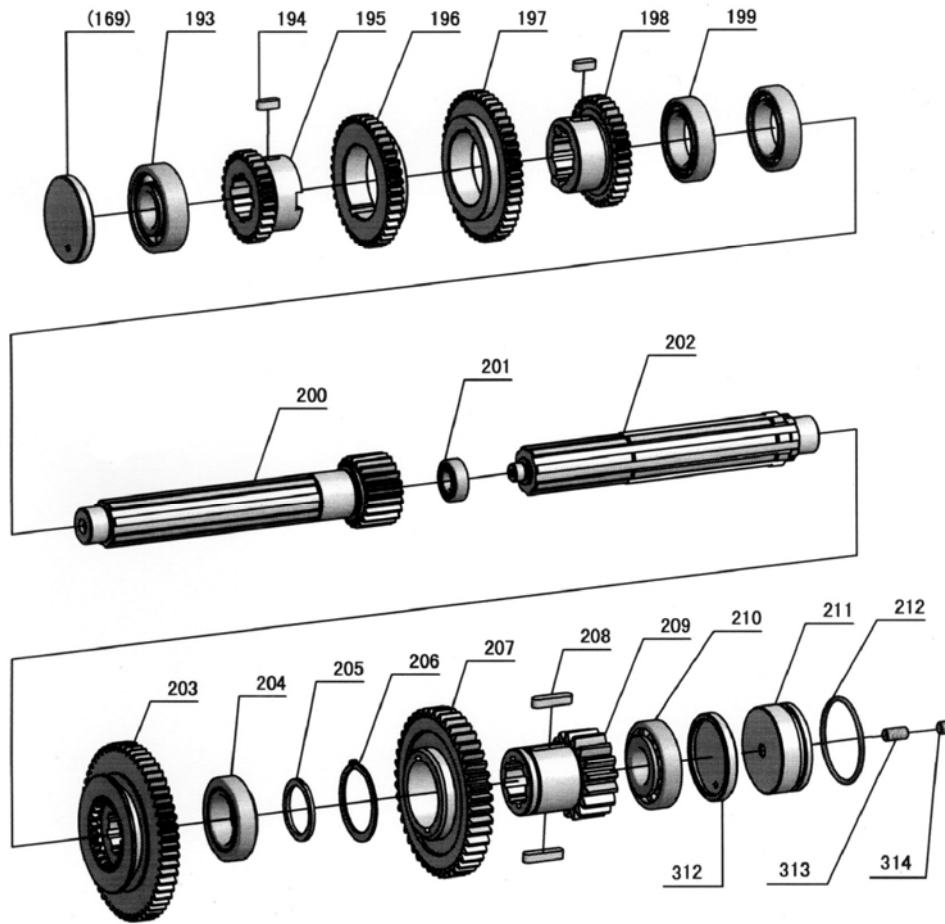

I

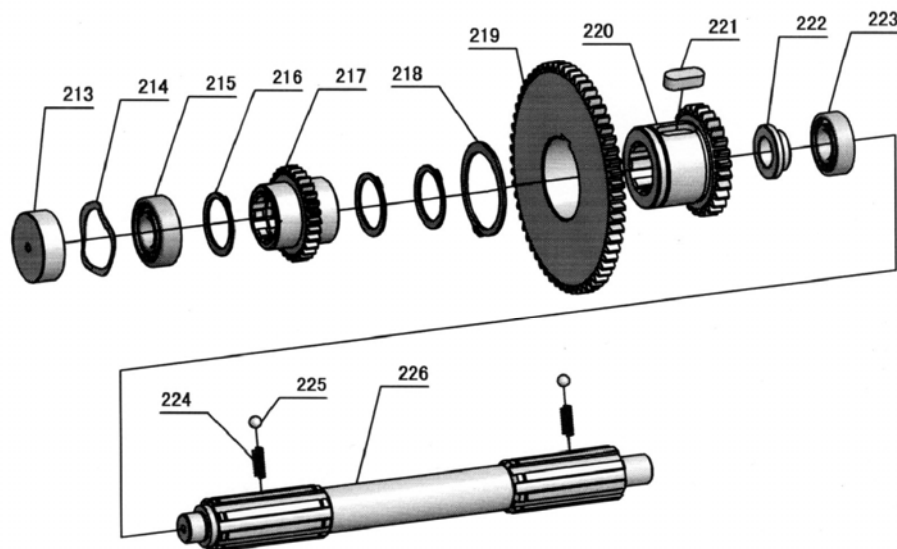

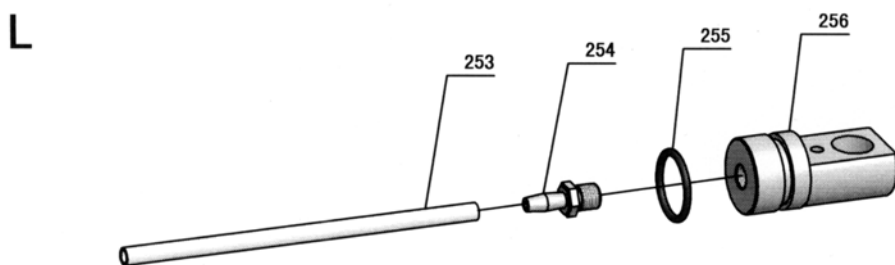
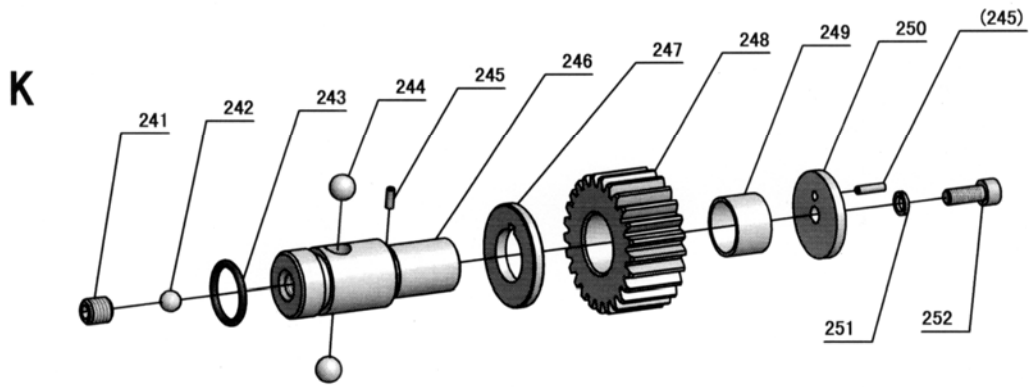
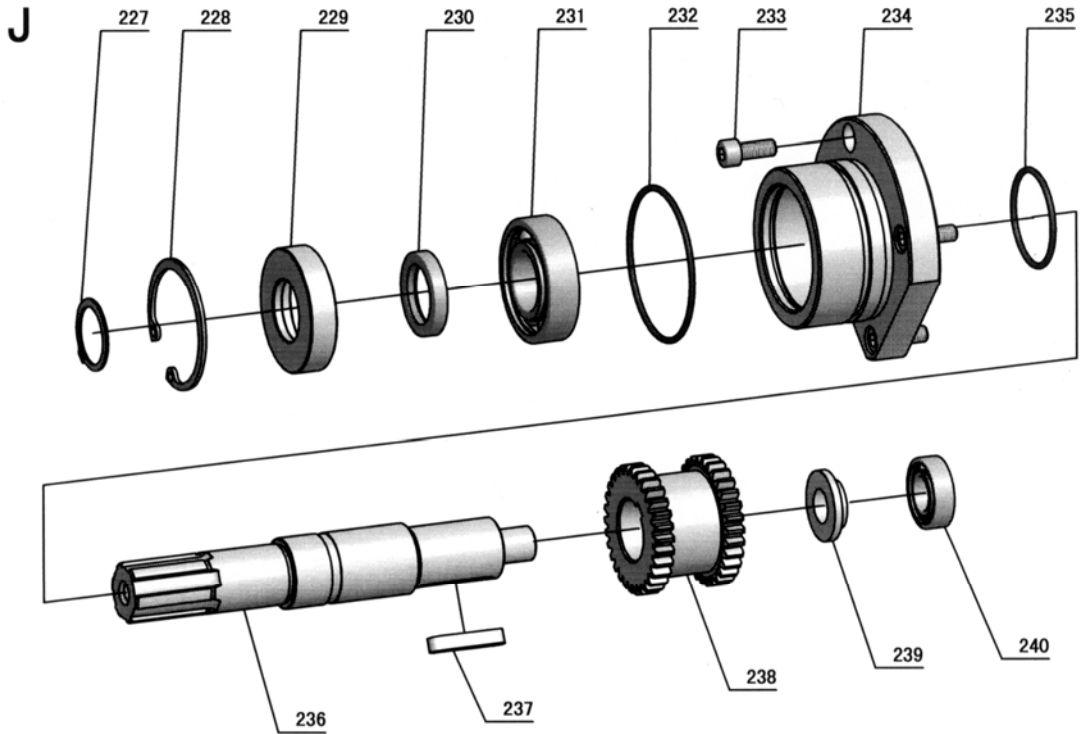

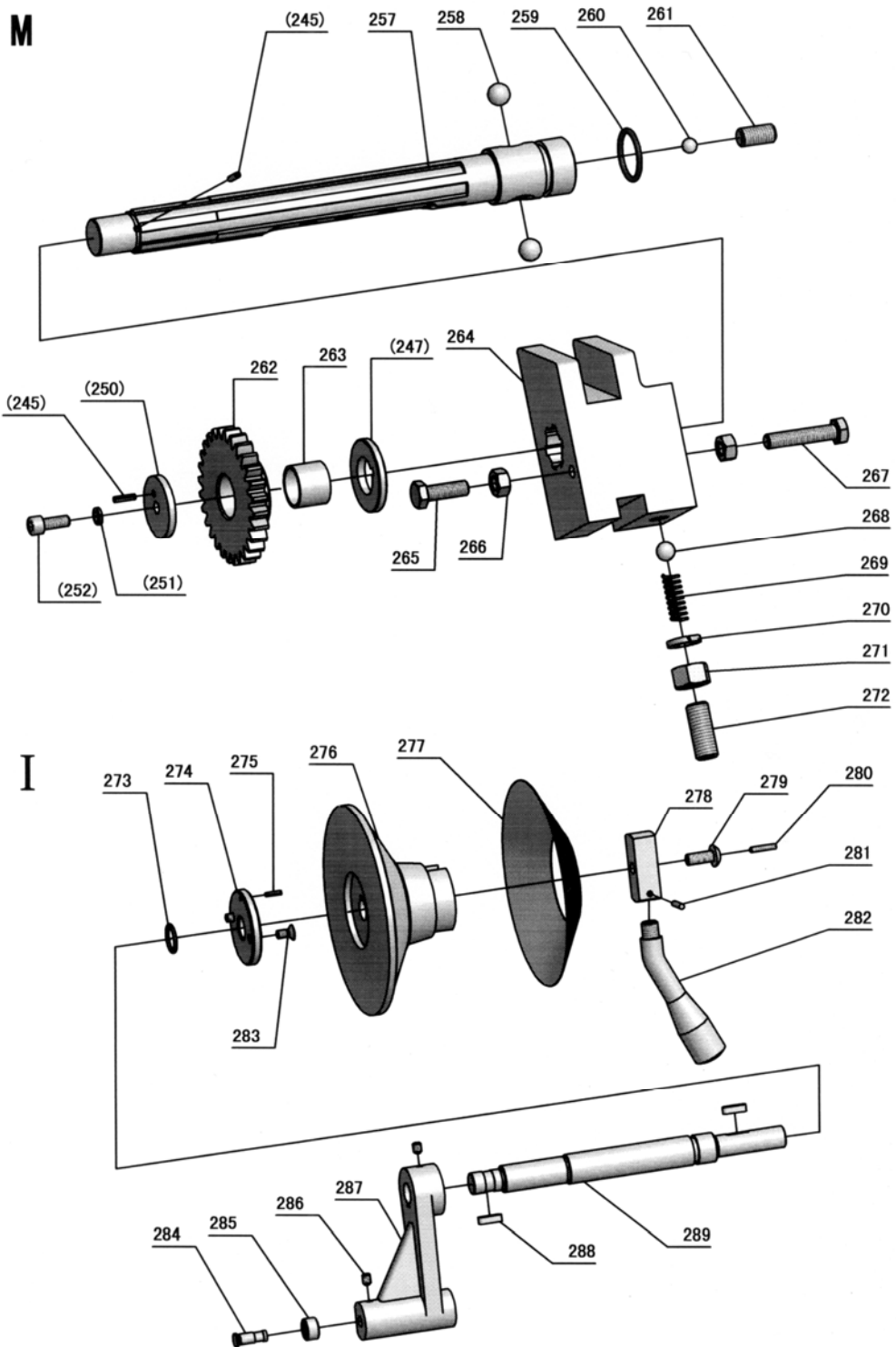

II

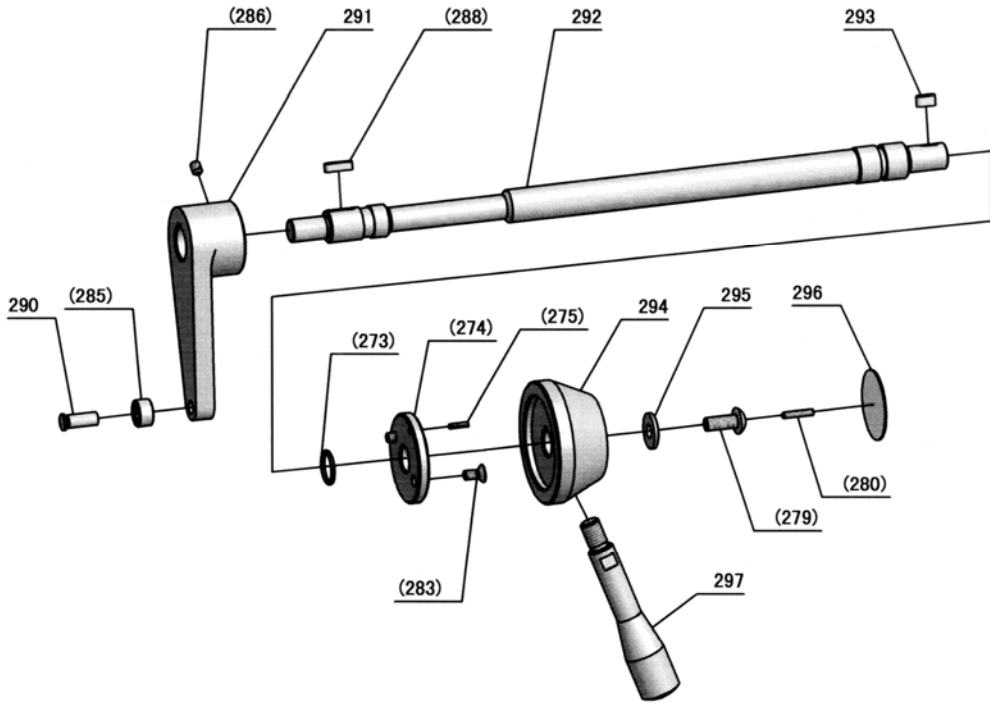

III

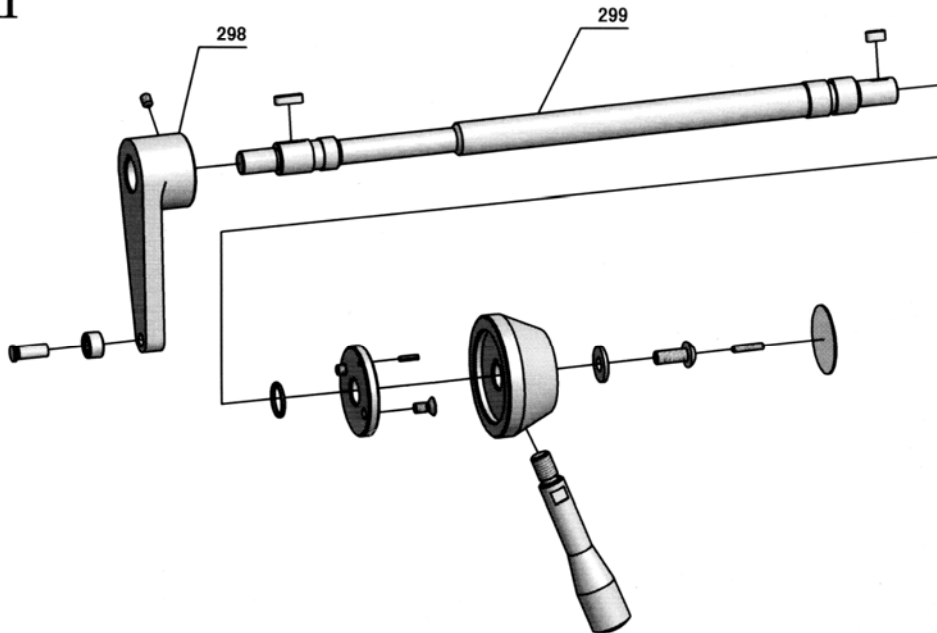

IV

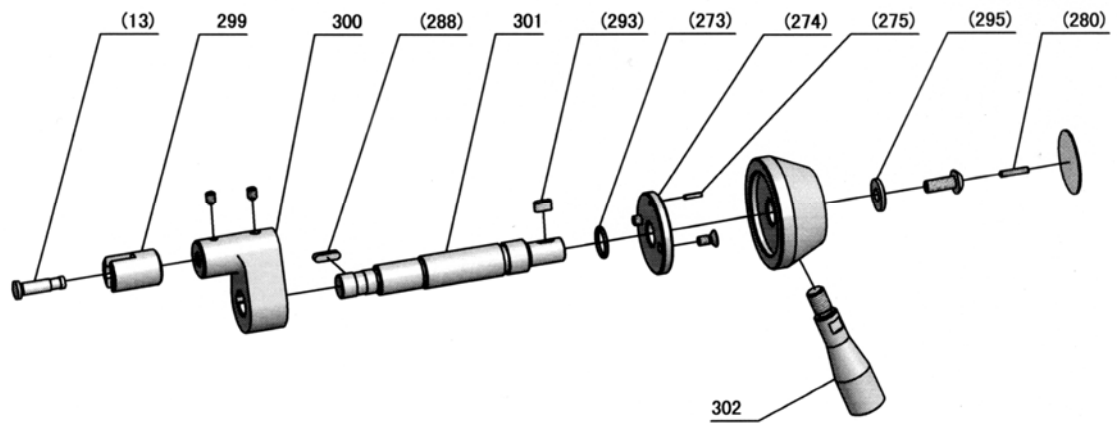

V

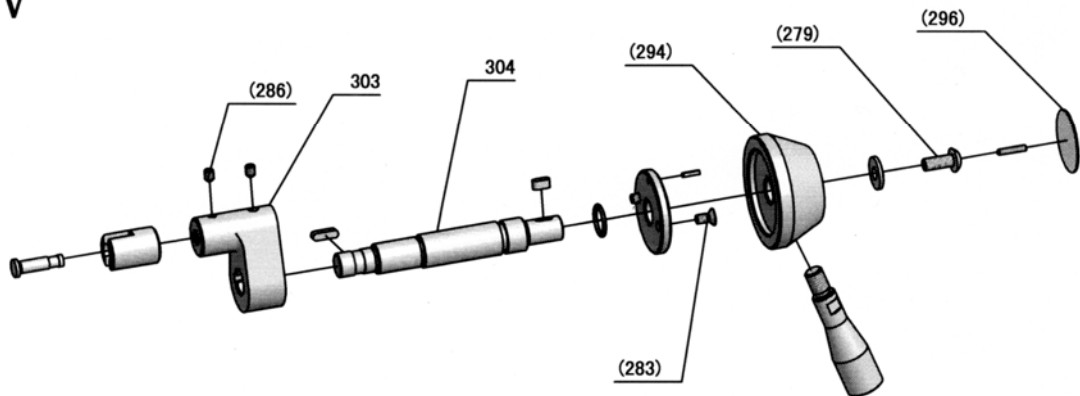

No.	Part No.	Name	Specifications	Qty.
1	GB77-85	Screw	M8×30	2
2	GB6170-86	Hexagon Nut Type 1	M8	2
3	GB70-85	Hexagon Socket Cap Set Screw	M8×20	7
4	C6266A-04-81-1	Gasket For End Cover		1
5	C6266A-04-121	Vertical Shaft		1
5	CQ6280-04-121	Vertical Shaft		1
6	GB1096-79	Round-Head Ordinary Flat Key	A6×20	1
7	GB3452.1-1992	Rubber O Ring	28×2.65	2
8	C6266A-04-122	Shaft Sleeve		1
8	CQ6280-04-122	Shaft Sleeve		1
9	C6266A-04-119	Swinging Arm		1
10	C6266A-04-120	Washer		1
11	GB70-85	Hexagon Socket Cap Set Screw	M6×16	1
12	C6266A-04-118	Slide Block		1
13	C6266A-04-99	Mandrel		3
14	C6266A-04-134	Oil Pipe		1
15	25595-1	Pipe Clip	φ 10	2
16	GB70-85	Hexagon Socket Cap Screw	M5×8	2
17	GB70-85	Hexagon Socket Cap Screw	M8×35	9
18	C6266A-04-02	Spindle Box Cover		2
19	GB80-85	Screw	M8×8	4
20	C6266A-04-131	Technological End Cap		1
21	C6266A-04-125	Pin Roll		1
22	GB3452.1-1992	Rubber O Ring	23.6×2.65	1
23	C6266A-04-123	Brake Support		1
24	GB819-85	Screw	M6×12	1
25	C6266A-04-124	Retaining Ring		1
26	GB91-86	Cotter Pin	2×12	2
27	GB77-85	Hexagon Socket Set Screw	M12X12	1
28	C6266A-04-132	Compression Spring		1
29	GB308-84	Steel Ball	φ 10	1
30	C6266A-04-01	Spindle Box Body		1
30	CQ6280-04-01	Spindle Box Body		1
31		Aluminum Alloy Oil Glass	M27×1.5	1
32	C6266A-04-116	Large Rating Plate	δ1.5	1
32	CQ6280-04-116	Large Rating Plate	δ1.5	1
33	GB70-85	Hexagon Socket Cap Screw	M16×70	1
34	C6266A-04-135	Pressure Plate		1
35	GB70-85	Hexagon Socket Cap Screw	M16×55	2
36	GB818-85	Screw	M3×6	12

No.	Part No.	Name	Specifications	Qty.
37	GB/T70.2-2000	Screw	M6×10	2
38	C6266A-04-136	Baffle Plate		1
39	C6266A-04-81	End Cover		1
40	GB70-85	Hexagon Socket Cap Set Screw	M16×50	3
41	GB120-86	Pin	16×55	1
42	GB119-86	Cylindrical Pin	A10×60	1
43	GB77-85	Screw	M12×12	1
44	GB70-85	Hexagon Socket Cap Screw	M10×80	1
45	C6266A-04-139	Oil Scavenge Connector		3
46	C6266A-04-46	Washer		1
47	GB278-89	Ball Braring	80108	2
48	GB70-85	Hexagon Socket Cap Screw	M6×12	4
49	C6266A-04-06	Bearing Block	M2.5, Z42	1
50	GB70-85	Hexagon Socket Cap Set Screw	M6×12	4
51	GB6170-86	Hexagon Nut Type 1	M12	2
52	C6266A-04-130	Screw Bolt		1
53	C6266A-04-129	Brake Ribbon		1
54	GB893.2-86	Circlip For Hole	68	2
55	GB894.1-86	Circlip For Shaft	40	1
56	C6266A-04-48	Pressing Sleeve		1
57	GB278-89	Ball Braring	80207	1
58	GB894.1-86	Circlip For Shaft	35	1
59	C6266A-04-146	Oil Pump Coupling Sleeve		1
60	C6266A-04-137	Oil Pump Coupling		1
61	SNBY2.5/0.5	Oil Pump		1
62	C6266A-04-58	Stopper		1
63	GB/T3452.1-1992	Rubber O Ring	73×2.65	1
64	G52-2	Combined Sealing Washer	14	2
65	C6266A-04-148	Connector Body M14		1
66	G52-2	Combined Sealing Washer	18	1
67	GB308-84	Steel Ball	φ 8	1
68	C6246B-101087	Connector Body M14/10		1
69	C6266A-04-140	Straight Coupling		1
70	30242	Nylon Pipe	φ 10×1300	1
71	C6246B-101088	Connector Body M18/10		1
72	WU-16×180-J	Oil Filter		1
73	C6266A-04-51	Input Shaft		1
74	GB120-86	Pin	6×20	2
75	C6266A-04-128	Roller		1
76	C6266A-04-126	Brake Base		1

No.	Part No.	Name	Specifications	Qty.
77	C6266A-04-127	Pin Roll		1
78	GB119-86	Cylindrical Pin	A4X35	1
79	C6266A-04-50	Pull Rod		1
80	C6266A-04-49	Lever		1
81	GB119-86	Cylindrical Pin	A8×28	1
82	C6266A-04-39	Copper Sheathing		1
83	C6266A-04-05	Friction Plate Holder	M2.5, Z55	1
84	C6266A-04-38	Spacing Collar		1
85	GB119-86	Cylindrical Pin	D5×10	2
86	C6266A-04-40	Spline Washer I		2
87	C6266A-04-41	Spline Washer Ii		2
88	C6266A-04-42	Friction Plate		16
89	GB1096-79	Round-Head Ordinary Flat Key	A10×80	1
90	C6266A-04-44	Spline Housing		1
91	C6266A-04-53	Compression Spring		2
92	C6266A-04-52	Check Pin		2
93	C6266A-04-45	Adjusting Screw Nut		2
94	C6266A-04-43	Friction Plate		14
95	C6266A-04-47	Friction Plate Holder		1
96	GB812-88	Round Nut	M33×1.5	1
97	GB858-88	Lock Washer For Round Nut	33	1
98	GB70-85	Hexagon Socket Cap Set Screw	M8×20	11
99	C6266A-04-34	Flange		1
100	C6266A-04-35	Belt Pulley		1
101	GB894.1-86	Circlip For Shaft	60	1
102	C6266A-04-36	Distance Bushing		1
103	GB278-89	Ball Braring	80112	2
104	GB119-86	Cylindrical Pin	A12×70	1
105	GB/3452.1-1992	Rubber O Ring	136×3.55	1
106	GB/T13871-1992	Rotary Shaft Lip Seal	FB040055	1
107	GB893.2-86	Circlip For Hole	80	1
108	GB120-86	Pin	8×24	2
109	C6266A-04-37	Bearing Block		1
110	GB278-89	Ball Braring	80208	1
111	C6266A-04-38	Spacing Collar		1
112	C6266A-04-54	Stopper		2
113	C6266A-04-96	Transmission Fork		1
114	C6266A-04-95	Locking Block		1
115	GB70-85	Hexagon Socket Cap Set Screw	M6×30	2
116	C6266A-04-94	Shaft		1

No.	Part No.	Name	Specifications	Qty.
117	GB/T3452.1-1992	Rubber O Ring	36.5×1.8	1
118	C6266A-04-93	Shaft Sleeve		1
119	C6266A-04-55	Idle Shaft		1
120	GB278-89	Ball Braring	80205	2
121	GB893.1-86	Circlip For Hole	52	1
122	C6266A-04-04	Idle Wheel	M2.5,Z32	1
123	C6266A-04-56	Spacing Collar		1
124	C6266A-04-57	Sheath		1
125	GB77-85	Screw	M10×10	2
126	GB308-84	Steel Ball	φ 8	2
127	GB/T3452.1-1992	Rubber O Ring	22.4×2.65	2
128	C6266A-04-105	Supporting Axle		1
129	GB308-84	Steel Ball	φ 12	4
130	C6266A-04-102	Locating Shaft		1
131	GB119-86	Cylindrical Pin	A6×16	1
132	C6266A-04-109	Transmission Fork		1
133	GB308-84	Steel Ball	φ 10	2
134	C6266A-04-132	Compression Spring		2
135	C6266A-04-112	Transmission Fork		1
136	GB6170-86	Hexagon Nut Type 1	M12	2
137	GB93-87	Standard Type Spring Washer	12	2
138	GB77-85	Screw	M12×30	2
139	C6266A-04-71	Balancing Sheet		2
140	GB79-85	Screw	M6×10	4
141	C6266A-04-32	Locking Screw Nut		1
142	GB77-85	Screw	M10×10	1
143	GB70-85	Hexagon Socket Cap Screw	M8×45	5
144	C6266A-04-73	Rear End Cover		1
145	C6266A-04-73-1	Gasket For Rear End Cover		1
146	C6266A-04-72	Oil Scavenge Ring		1
147	GB276-89	Deep Groove Ball Bearing	124	1
148	GB77-85	Screw	M10×10	1
149	C6266A-04-31-1	Pressure Plate		1
150	C6266A-04-31	Locking Screw Nut		1
151	C6266A-04-24	Gear Wheel	M2.5, Z60	1
152	C6266A-04-32-1	Pressure Plate		1
153	C6266A-04-74	Distance Bushing		1
154	GB297-84	Conical Roller Bearing	D2007926E	1
155	GB70-85	Hexagon Socket Cap Screw	M8×35	1
156	C6266A-04-22	Gear Wheel	M3, Z54	1

No.	Part No.	Name	Specifications	Qty.
157	GB80-85	Screw	M8×8	2
158	C6266A-04-23	Gear Wheel	M3.5, Z68	1
159	GB297-84	Conical Roller Bearing	D2007128E	1
160	GB/T3452.1-1992	Rubber O Ring	212×5.3	1
161	C6266A-04-75	Front End Cover		1
162	GB70-85	Hexagon Socket Cap Set Screw	M8×35	6
163	C6266A-04-03	Spindle		1
164	C6266A-04-77	Screw For Cam Lock		6
165	RUN6246-101082-1	Spring		6
166	C6266A-04-76	Cam Lock		6
167	GB1567-79	Round-Head Thin Flat Key	A8×70	1
168	GB1096-79	Round-Head Ordinary Flat Key	A12×100	1
169	C6266A-04-59	Top Cover		2
170	GB278-89	Ball Braring	80207	1
171	C6266A-04-07	Gear Wheel	M2.5, Z55	1
172	C6266A-04-08	Gear Wheel	M2.5, Z48	1
173	C6266A-04-09	Gear Wheel	M2.5, Z35	1
174	C6266A-04-10	Gear Wheel	M2.5, Z29	1
175	C6266A-04-11	Gear Wheel	M2.5, Z42	1
176	C6266A-04-61	Spacing Collar		1
177	GB278-89	Ball Braring	80206	2
178	C6266A-04-60	Spline Shaft		1
179	GB1096-79	Round-Head Ordinary Flat Key	A8×28	1
180	C6266A-04-13	Gear Shaft	M2.5, Z20	1
181	C6266A-04-62	Spacing Collar		1
182	C6266A-04-12	Gear Wheel	M2.5, Z54	1
183	GB73-85	Slotted Plain-Head Set Screw	M8×12	1
184	GB921-86	Steel Wire Locking Collar	D=71	1
185	GB278-89	Ball Braring	80106	1
186	C6266A-04-63	Top Cover		1
187	GB77-85	Screw	M10×10	1
188	GB/3452.1-1992	Rubber O Ring	51.5×2.65	1
189	GB278-89	Ball Braring	80106	1
190	C6266A-04-64	Stopper		1
191	GB77-85	Screw	M10×20	2
192	C6266A-04-65	Stopper		1
193	GB278-89	Ball Braring	80306	1
194	GB1096-79	Round-Head Ordinary Flat Key	A8×20	2
195	C6266A-04-14	Gear Wheel	M2.5, Z28	1
196	C6266A-04-15	Gear Wheel	M2.5, Z41	1

No.	Part No.	Name	Specifications	Qty.
197	C6266A-04-16	Gear Wheel	M2.5, Z47	1
198	C6266A-04-17	Gear Wheel	M2.5, Z34	1
199	GB278-89	Ball Braring	80108	2
200	C6266A-04-18	Gear Wheel	M2.5, Z22	1
201	GB278-89	Ball Braring	80202	1
202	C6266A-04-68	Spline Shaft		1
203	C6266A-04-19	Gear Wheel	M2.5, Z22/Z56	1
204	GB297-84	Conical Roller Bearing	2007108E	1
205	C6266A-04-69	Distance Bushing		1
206	GB894.1-86	Circlip For Shaft	55	1
207	C6266A-04-20	Gear Wheel	M3, Z46	1
208	GB1096-79	Round-Head Ordinary Flat Key	A8×36	2
209	C6266A-04-21	Gear Wheel	M3.5, Z17	1
210	GB297-84	Conical Roller Bearing	7306E	1
211	C6266A-04-70	Stopper		1
212	GB/3452.1-1992	Rubber O Ring	65×3.55	1
213	C6266A-04-78	Stopper		1
214	JB/T7590-94	Wave Washer	47	3
215	GB278-89	Ball Braring	80204	1
216	GB894.1-86	Circlip For Shaft	36	1
217	C6266A-04-25	Gear Wheel	M2, Z30	1
218	GB894.1-86	Circlip For Shaft	55	1
219	C6266A-04-26	Gear Wheel	M2.5, Z60	1
220	C6266A-04-27	Gear Wheel	M2.5, Z28	1
221	GB1096-79	Round-Head Ordinary Flat Key	A12×28	1
222	C6266A-04-80	Sheath		1
223	GB278-89	Ball Braring	80104	1
224	C6266A-04-133	Compression Spring		2
225	GB308-84	Steel Ball	φ 8	2
226	C6266A-04-79	Shaft		1
227	GB894.1-86	Circlip For Shaft	30	1
228	GB893.2-86	Circlip For Hole	62	1
229	C6266A-04-85	Sealing Shaft Sleeve		1
230	GB/T13871-1992	Rotary Shaft Lip Seal	FB030042	1
231	GB278-89	Ball Braring	80206	1
232	GB3452.1-1992	Rubber O Ring	73×2.65	1
233	GB70-85	Hexagon Socket Cap Screw	M8×20	3
234	C6266A-04-84	Flange		1
235	GB?13452.1-1992	Rubber O Ring	45×2.65	1
236	C6266A-04-86	Output Shaft		1

No.	Part No.	Name	Specifications	Qty.
237	GB1096-79	Round-Head Ordinary Flat Key	A8×40	1
238	C6266A-04-28	Gear Wheel	M2, Z30	1
239	C6266A-04-87	Spacing Collar		1
240	GB278-89	Ball Braring	80103	1
241	GB77-85	Screw	M10×10	1
242	GB308-84	Steel Ball	φ 8	1
243	GB/T3452.1-1992	Rubber O Ring	20×2.65	1
244	GB308-84	Steel Ball	φ 10	2
245	GB879-86	Pin	3×12	4
246	C6266A-04-88	Output Idler Shaft		1
247	C6266A-04-89	Spacing Collar		2
248	C6266A-04-30	Gear Wheel	M2, Z25	1
249	SF-1	Oil-Free Lubrication Bearing	2025	1
250	C6266A-04-90	Retaining Ring		2
251	GB93-87	Standard Type Spring Washer	6	2
252	GB70-85	Hexagon Socket Cap Set Screw	M6×16	2
253		Lucite Pipe	φ 5×δ1×150	1
254	C6266A-04-83	Oil Outlet Connector		1
255	GB/T3452.1-1992	Rubber O Ring	23.6×2.65	1
256	C6266A-04-82	Oil Outlet Plug		1
257	C6266A-04-91	Shaft		1
258	GB308-84	Steel Ball	φ 12	2
259	GB/T3452.1-1992	Rubber O Ring	23.6×2.65	1
260	GB308-84	Steel Ball	φ 8	1
261	GB77-85	Screw	M10×20	1
262	C6266A-04-29	Gear Wheel	M2.5, Z28	1
263	SF-1	Oil-Free Lubrication Bearing	2018	1
264	C6266A-04-92	Transmission Fork Block		1
265	GB5783-86	Hexagon Head Bolt	M8×25	1
266	GB6170-86	Hexagon Nut Type 1	M8	2
267	GB5783-86	Hexagon Head Bolt	M8×40	1
268	GB308-84	Steel Ball	φ 10	1
269	C6266A-04-132	Compression Spring		1
270	GB93-87	Standard Type Spring Washer	12	1
271	GB6170-86	Hexagon Nut Type 1	M12	1
272	GB77-85	Screw	M12×30	1
273	GB1235-76	Rubber O Ring	22×2.4	5
274	RUN6246-101067	Locater Card		5
275	GB879-86	Resilient Cylindrical Pin	3×12	5
276	C6266A-04-108	Speed- Changeable Wheel		1

No.	Part No.	Name	Specifications	Qty.
277	C6266A-04-117	Speed Rating Plate	δ0.5	1
278	C6266A-04-145	Fixed Block		1
279	RUN6246-101088	Screw		5
280	GB80-85	Screw	M4×20	5
281	GB119-86	Cylindrical Pin	A4×20	1
282	C6266A-04-144	Handle		1
283	GB819-85	Screw	M6×12	10
284	C6266A-04-113	Mandrel		1
285	C6266A-04-110	Sheath		3
286	GB80-85	Screw	M6×8	10
287	C6266A-04-114	Swinging Arm		1
288	GB1096-79	Round-Head Ordinary Flat Key	A5×18	6
289	C6266A-04-115	Fork Rod		1
290	C6266A-04-111	Mandrel		2
291	C6266A-04-106	Swinging Arm		1
292	C6266A-04-107	Fork Rod		2
293	GB1096-79	Round-Head Ordinary Flat Key	A5×12	4
294	C6266A-04-141	Speed Change Handle		4
295	RUN6246-101070-1	Washer		4
296	RUN6246-101099	Rating Plate	δ1	4
297	C6266A-04-142	Handle Lever		2
298	C6266A-04-97	Swinging Arm		1
299	C6266A-04-98	Transmission Fork		2
300	C6266A-04-100	Swinging Arm		1
301	C6266A-04-101	Fork Rod		1
302	C6266A-04-143	Handle Lever		2
303	C6266A-04-103	Swinging Arm		1
304	C6266A-04-104	Fork Rod		1
305	GB3452.1-82	Rubber O Ring	53×3.55	1
306	C6266A-04-150	Vertical Shaft Stand		1
307	GB70-85	Screw	M6×25	6
308	C6266A-04-149	One Way Valve Part		1
309	GB879-86	Pin	3×14	1
310	25677	Biconical Cutting Ferrule		4
311	25568	Oil Pipe Connector		4
312	C6266A-04-151	Top Cover		1
313	GB77-85	Screw	M16×40 × P1.5	1
314	GB6173-86	Nut	M16 × 1.5	1

Gearbox

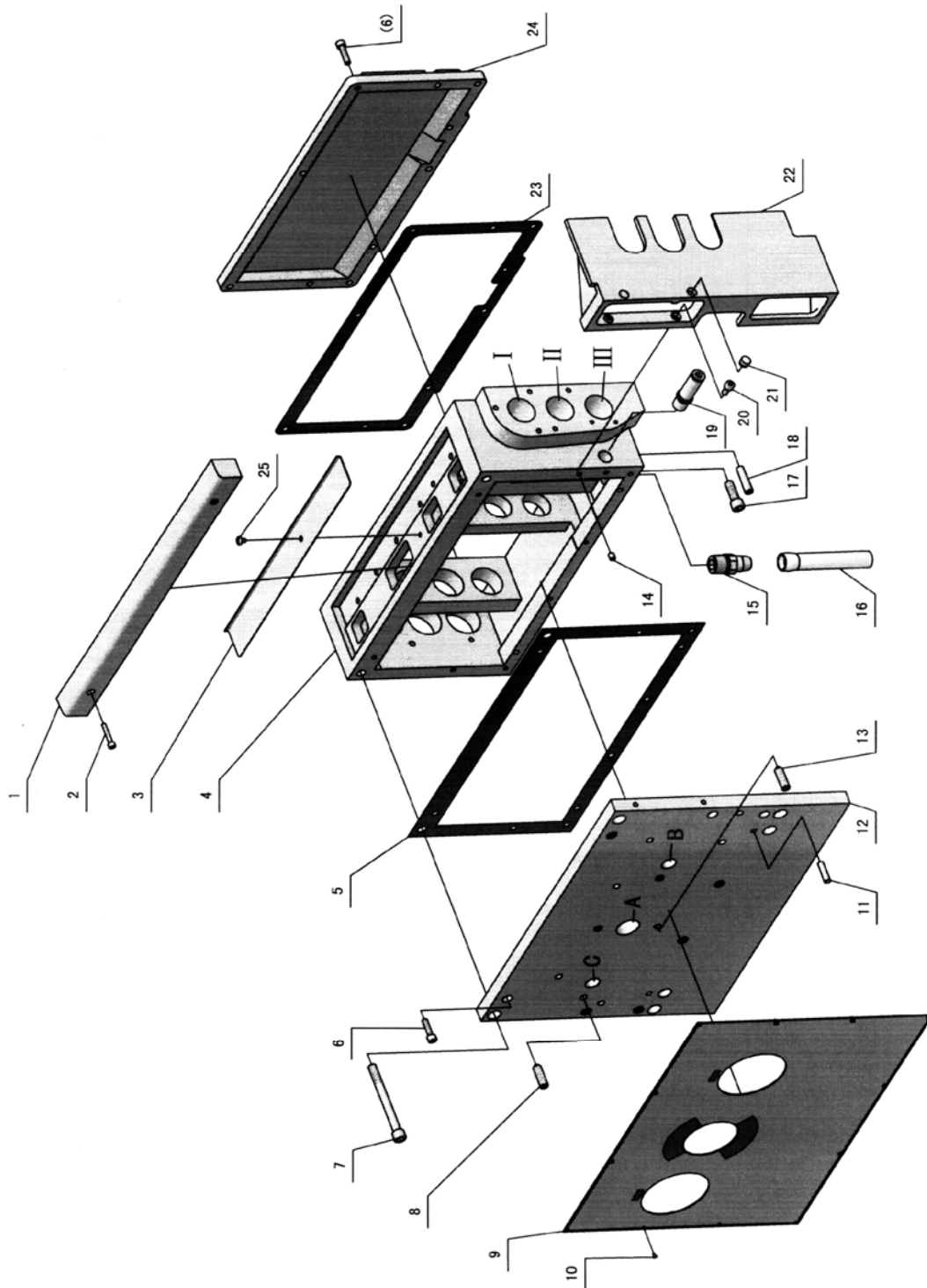

I

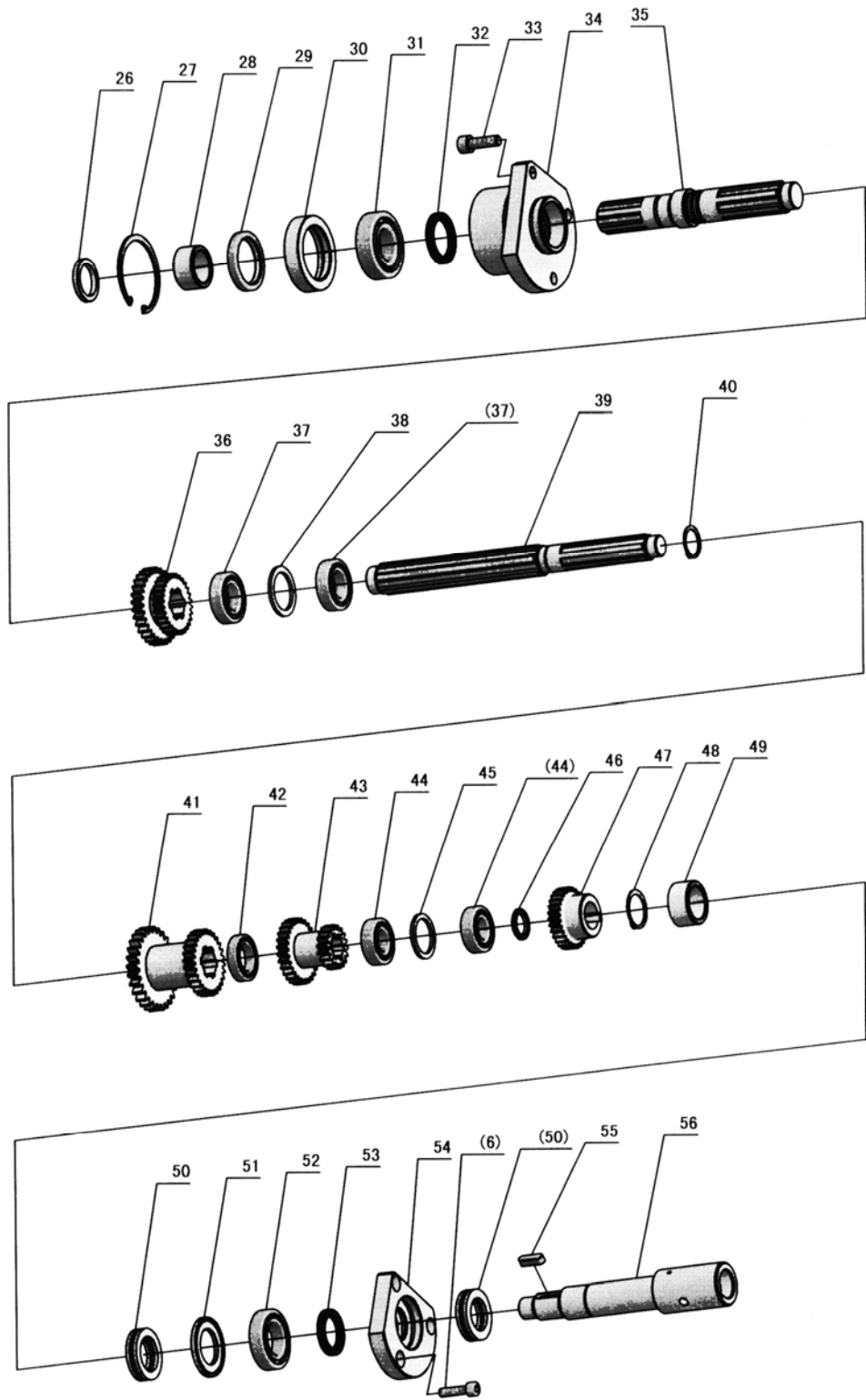

II

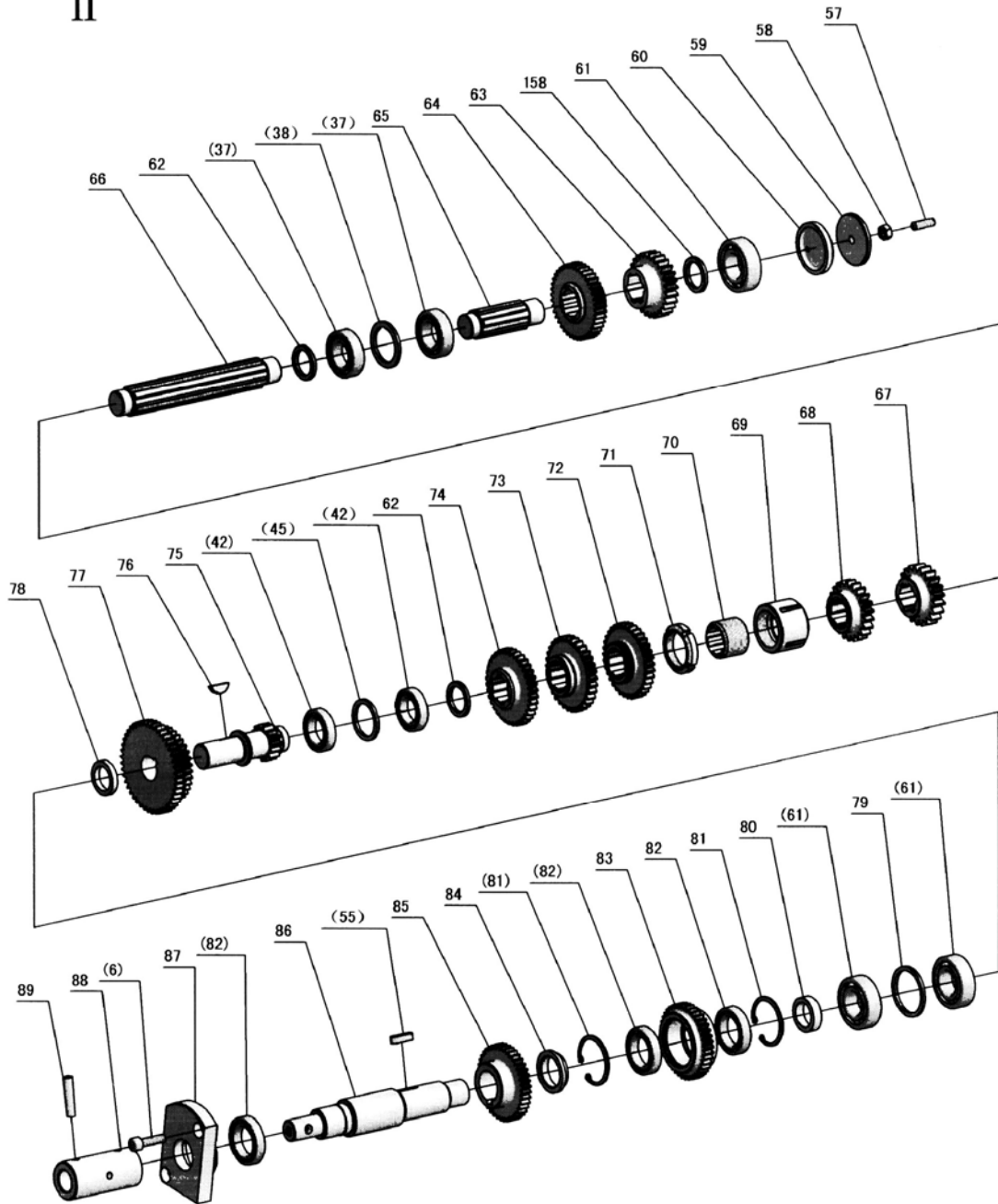

III

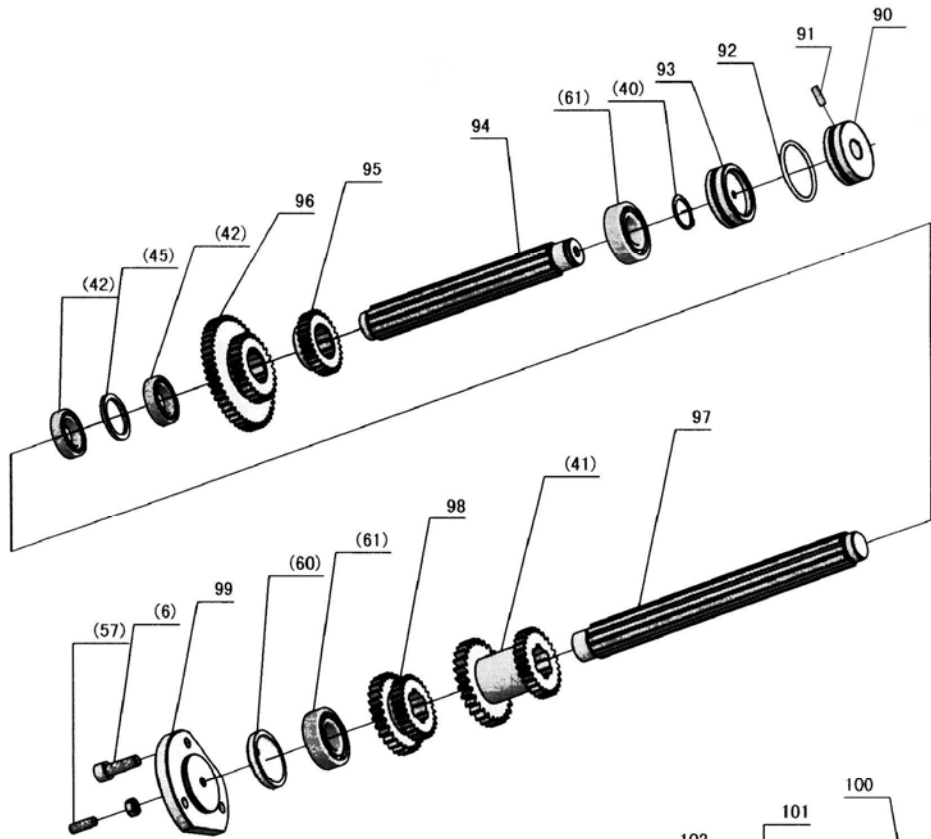

A

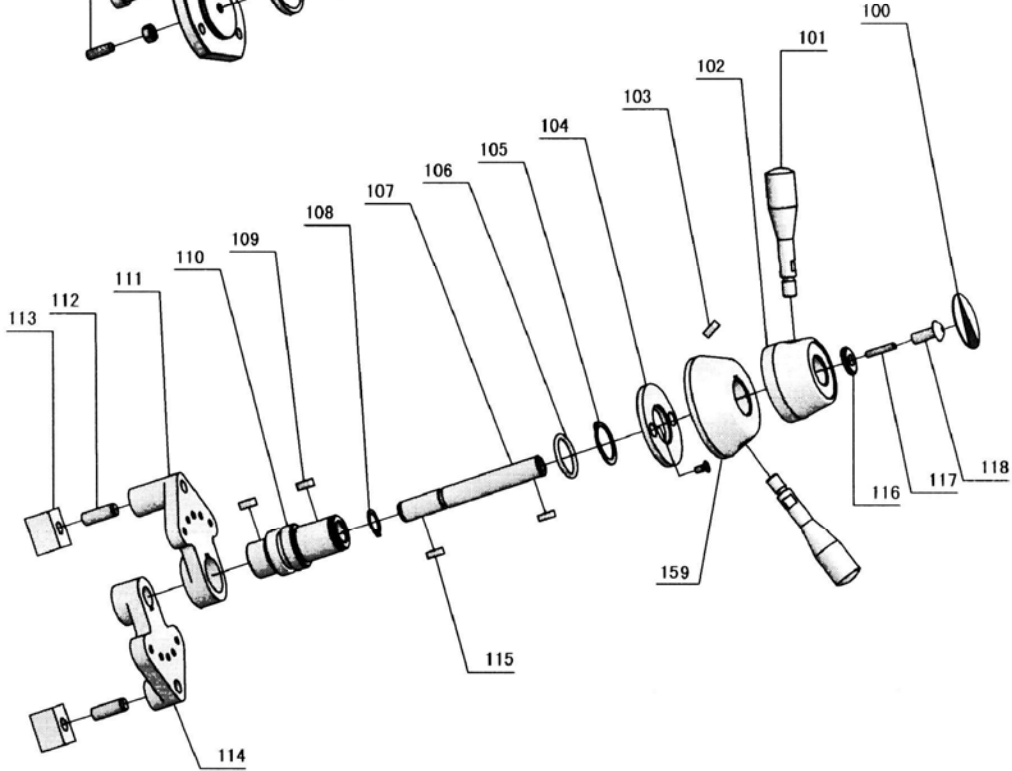

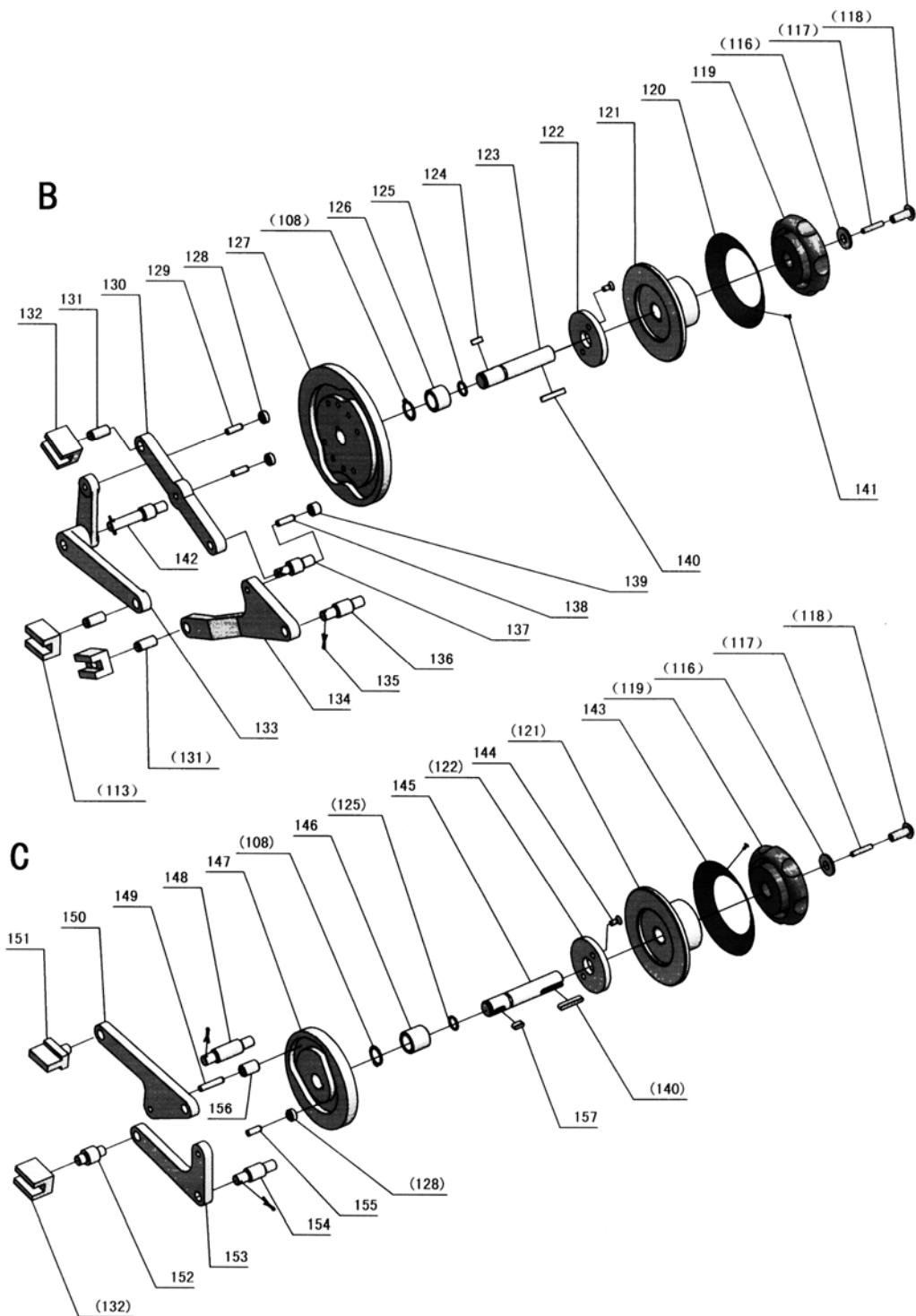

NO.	Part No.	Name	Specifications	Qty
1	C6266A-05-101	Top Cover Of Feeding Box		1
2	GB70-85	Hexagon Socket Cap Set Screw	M6×35	2
3	C6266A-05-04	Cover Plate		1
4	C6266A-05-01	Feeding Box Body		1
5	C6266A-05-77	Gasket For Front Cover		1
6	GB70-85	Hexagon Socket Cap Screw	M8X30	26
7	GB70-85	Hexagon Socket Cap Screw	M12×150	2
8	Z5035-03-28	Locating Screw		3
9	C6266A-05-92	Panel Of Feeding Box		1
10	GB818-85	Screw	M3X5	12
11	GB117-86	Tapered Cottar	8X35	2
12	C6266A-05-03	Front Cover Of Feeding Box		1
13	C6266A-05-82	Locating Screw		1
14	GB78-85	Screw	M8X10	1
15	C6266A-05-99	Connector		1
16		Lucite Pipe	φ 20×δ2×500	1
17	GB70-85	Hexagon Socket Cap Set Screw	M12×35	2
18	GB118-86	Tapered Cottar	10×45	2
19	C6266A-05-83	Fulcrum Shaft For Control		1
20	GB70-85	Hexagon Socket Cap Screw	M8X16	2
21	C6266A-05-100	Stopper		2
22	C6266A-05-05	Pushbutton Support		1
23	C6266A-05-78	Sealing Washer For Rear Cover		1
24	C6266A-05-02	Rear Cover Of Feeding Box		1
25	GB818-85	Screw	M6X8	1
26	C6266A-05-46	Washer		1
27	GB893.1-86	Hole Baffle	70	1
28	C6266A-05-47	Distance Bushing		1
29	GB13871-1992	Rotary Shaft Lip Seal Ring	B4055	1
30	C6266A-05-48	Oil Sealing Sleeve		1
31	GB/T276-1994	Deep Groove Ball Bearing	6206	1
32	FJ145-63	Felt Ring	35	1
33	GB70-85	Hexagon Socket Cap Screw	M10X30	3
34	C6266A-05-49	End Cover I		1
35	C6266A-05-38	Shaft I		1
36	C6266A-05-20	Duplicate Gear	Z30/Z29	1
37	GB/T276-1994	Deep Groove Ball Bearing	6005	4
38	C6266A-05-50	Spacing Collar I		2
39	C6266A-05-42	Shaft V		1
40	GB894.1-86	Axle Bumper	25	2

NO.	Part No.	Name	Specifications	Qty
41	C6266A-05-24	Duplicate Gear	Z28/28	2
42	GB/T276-1994	Deep Groove Ball Bearing	61905	5
43	C6266A-05-30	Duplicate Gear	Z28/18	1
44	GB/T276-1994	Deep Groove Ball Bearing	6004	2
45	C6266A-05-51	Spacing Collar Ii		3
46	C6266A-05-52	Spacing Collar Iii		1
47	C6266A-05-37	Gear Wheel	Z29	1
48	GB894.1-86	Axle Bumper	30	1
49	C6266A-05-53	Distance Bushing I		1
50	GB/T301-1995	Thrust Ball Bearing	51106	2
51	C6266A-05-54	Shock Insulator		1
52	GB/T276-1994	Deep Groove Ball Bearing	6006	1
53	FJ145-63	Felt Ring	30	1
54	C6266A-05-55	End Cover Ii		1
55	GB1096-79	Round-Head Ordinary Flat Key	8X25	2
56	C6266A-05-45	Shaft VIII		1
57	GB6170-86	Hexagonal Nut	M8	2
58	GB74-85	Screws	M8X25	2
59	C6266A-05-56	Adjusting Cap		1
60	C6266A-05-57	Adjusting Cover		2
61	GB/T276-1994	Deep Groove Ball Bearing	6205	5
62	C6266A-05-104	Spacing Collar Iv		2
63	C6266A-05-21	Gear Wheel	Z27	1
64	C6266A-05-22	Gear Wheel	Z41	1
65	C6266A-05-39	Shaft II		1
66	C6266A-05-41	Shaft IV		1
67	C6266A-05-25	Gear Wheel	Z21	1
68	C6266A-05-26	Gear Wheel	Z22	1
69	C6266A-05-59	Adjusting Nut		1
70	C6266A-05-60	Adjusting Threaded Sleeve		1
71	C6266A-05-61	Round Nut		1
72	C6266A-05-27	Gear Wheel	Z35	1
73	C6266A-05-28	Gear Wheel	Z33	1
74	C6266A-05-29	Gear Wheel	Z36	1
75	C6266A-05-32	Pinion	Z15	1
76	GB1099-79	Semicircular Key	6X9X22	1
77	C6266A-05-31	Duplicate Gear	Z45/Z35	1
78	C6266A-05-62	Spacing Collar V		1
79	C6266A-05-63	Spacing Collar Vi		1
80	C6266A-05-64	Distance Bushing Ii		1

NO.	Part No.	Name	Specifications	Qty
81	GB893.1-86	Hole Baffle	47	2
82	GB/T276-1994	Deep Groove Ball Bearing	61906	3
83	C6266A-05-35	Gear Wheel	Z41	1
84	C6266A-05-65	Distance Bushing Iii		1
85	C6266A-05-36	Gear Wheel	Z41	1
86	C6266A-05-44	Shaft VII		1
87	C6266A-05-66	End Cover Iii		1
88	C6266A-05-67	Feeding Rod Coupling Sleeve		1
89	GB117-86	Tapered Cottar	8X40	2
90	C6266A-05-70	End Cover V		1
91	GB79-85	Screw	M10X20	1
92	GB3452.1-82	Rubber O Ring	46.2×2.65	1
93	C6266A-05-69	Distance Bushing Iv		1
94	C6266A-05-43	Shaft VI		1
95	C6266A-05-34	Gear Wheel	Z30	1
96	C6266A-05-33	Duplicate Gear	Z48/Z28	1
97	C6266A-05-40	Shaft III		1
98	C6266A-05-23	Duplicate Gear	Z28/Z30	1
99	C6266A-05-68	End Cover Iv		1
100	C6266A-05-102	Plate		1
101	C6266A-05-98	Handle Lever		2
102	C6266A-05-93	Gear B Handle Apparatus		1
103	C6266A-05-103	Plate		1
104	C6266A-05-81	Position Limit Washer		1
105	GB894.1-86	Axle Bumper	28	1
106	GB3452.1-82	Rubber O Ring	28X3.55	1
107	C6266A-05-79	Gear B Shifting Axle		1
108	GB894.1-86	Axle Bumper	16	3
109	GB1096-79	Round-Head Ordinary Flat Key	6X14	2
110	C6266A-05-80	Gear A Shifting Axle		1
111	C6266A-05-07	Gear A Swing Block		1
112	GB119-86	Cylindrical Pin	10X28	2
113	C6266A-05-17	Transmission Fork I		4
114	C6266A-05-06	Gear B Swing Block		1
115	GB1096-79	Round-Head Ordinary Flat Key	5X14	2
116	RUN6246-101070-1	Washer		3
117	GB80-85	With Cup Point	M5X25	3
118	RUN6246-101088	Screw		3
119	RUN6246-102053-2	Handwheel		2
120	C6266A-05-97	Rating Plate		1

NO.	Part No.	Name	Specifications	Qty
121	C6266A-05-95	Speed-Changeable Wheel		2
122	C6266A-05-75	Position Limit Washer		2
123	C6266A-05-84	Right Gear Shifting Shaft		1
124	GB1096-79	Round-Head Ordinary Flat Key	4X12	1
125	GB3452.1-82	Rubber O Ring	11.2X2.65	3
126	C6266A-05-85	Liner Bushing		1
127	C6266A-05-13	Large Cam		1
128	C6266A-05-72	Roller I		3
129	GB119-86	Cylindrical Pin	6X18	2
130	C6266A-05-09	Swinging Arm Ii		1
131	GB119-86	Cylindrical Pin	10X22	3
132	C6266A-05-16	Transmission Fork Ii		2
133	C6266A-05-08	Swinging Arm I		1
134	C6266A-05-10	Swinging Arm Iii		1
135	GB91-86	Cotter Pin	2X12	5
136	C6266A-05-86	Fulcrum Shaft Ii		1
137	C6266A-05-88	Fulcrum Shaft Iii		1
138	GB119-86	Cylindrical Pin	6X20	1
139	C6266A-05-89	Roller II		1
140	GB1096-79	Round-Head Ordinary Flat Key	B5X28	2
141	GB827-86	Rivet For Rating Plate	2X5	4
142	C6266A-05-87	Fulcrum Shaft I		1
143	C6266A-05-96	Rating Plate		1
144	GB819-85	Screw	M5X10	6
145	C6266A-05-74	Left Gear Shifting Shaft		1
146	C6266A-05-76	Liner Bushing		1
147	C6266A-05-14	Small Cam		1
148	C6266A-05-18	Fulcrum Shaft V		1
149	GB119-86	Cylindrical Pin	6X28	1
150	C6266A-05-12	Swinging Arm B		1
151	C6266A-05-15	Toggle Piece		1
152	C6266A-05-19	Fulcrum Shaft		1
153	C6266A-05-11	Swinging Arm A		1
154	C6266A-05-73	Fulcrum Shaft Iv		1
155	GB119-86	Cylindrical Pin	6X16	1
156	C6266A-05-71	Roller III		1
157	GB1096-79	Round-Head Ordinary Flat Key	5X12	1
158	C6266A-05-58	Spacing Collar Iv		1
159	C6266A-05-94	Gear A Handle Apparatus		1

Saddle

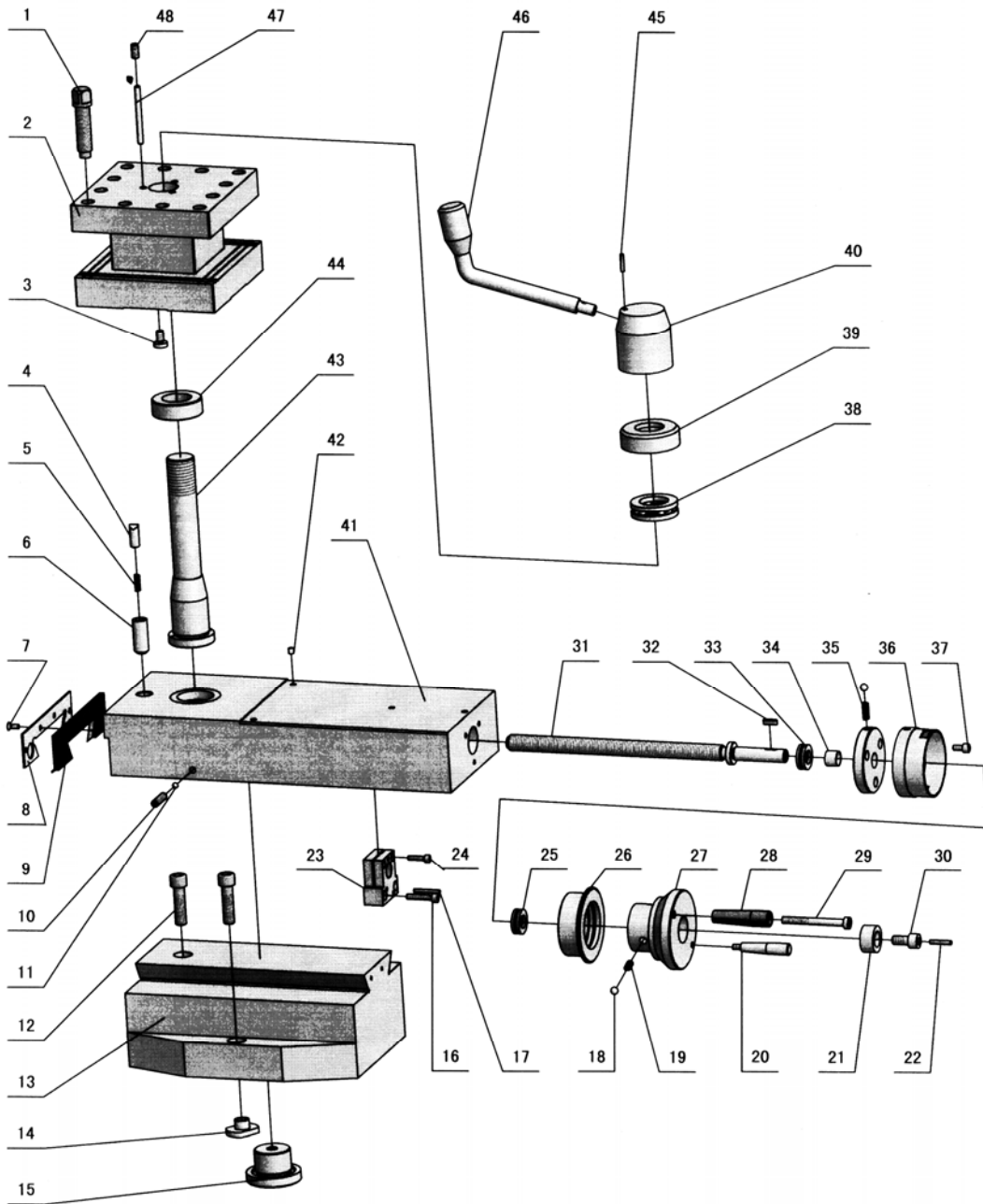

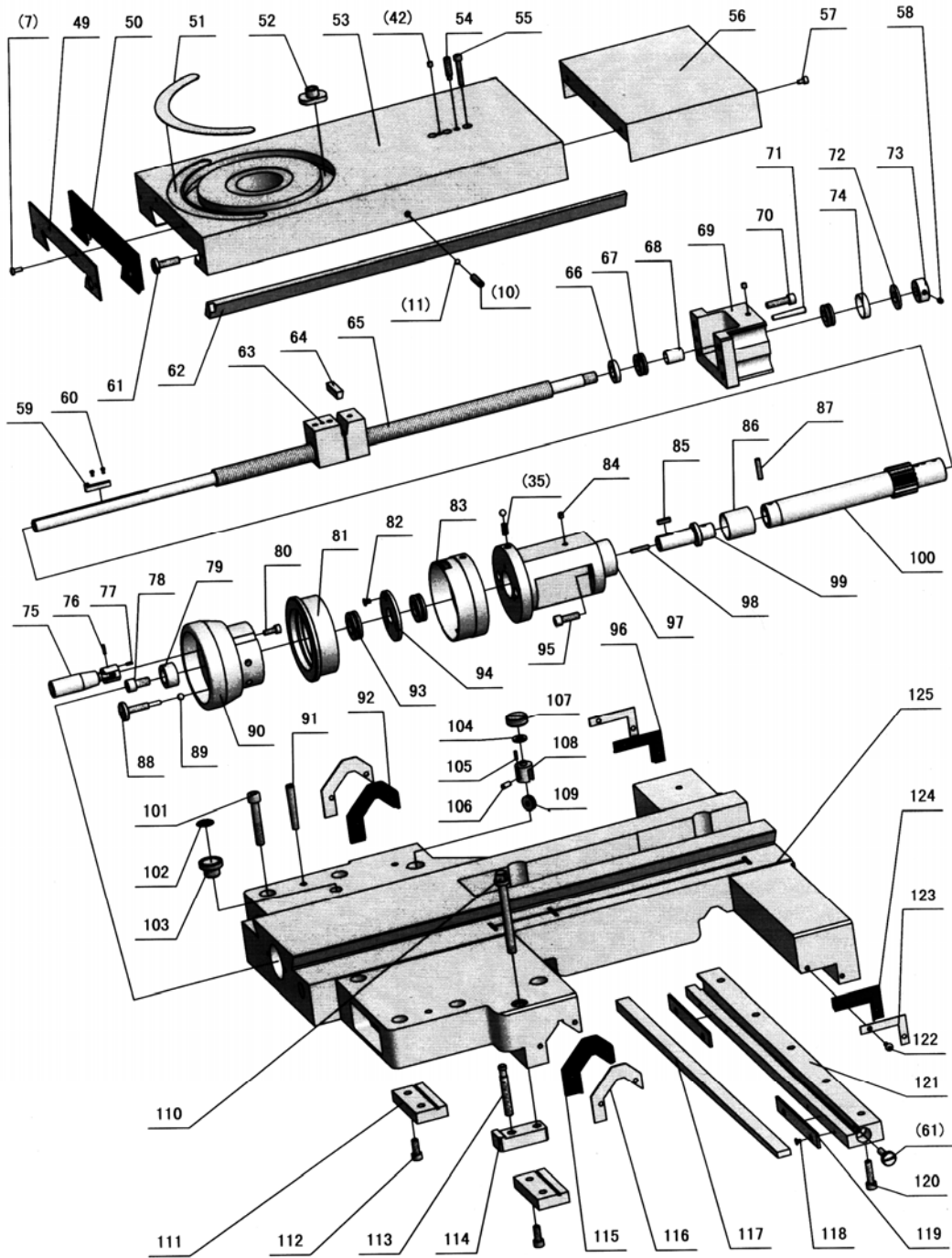

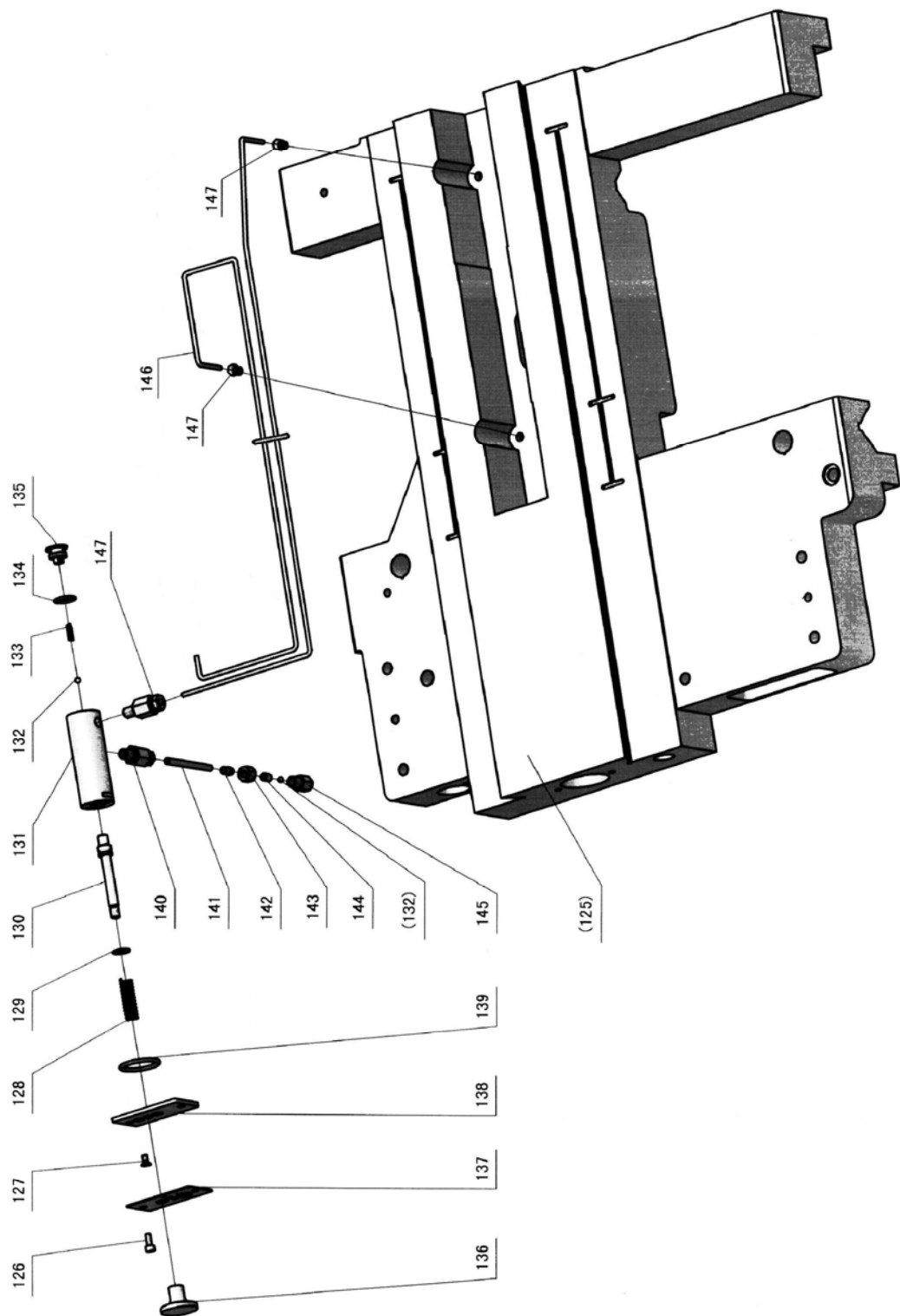

No	Part No.	Name	Specification	Qty.
1	GB/T 83	Screw	M16×65	12
2	C6266A-07-23	Square Tool Post		1
3	RUN6246-103058-2	Adjusting Screw	Shared part	3
4	C6266A-07-39	Bouncing Pin		1
5	GB/T 2089	Pressure Spring	1×5×18	1
6	C6266A-07-71	Locating Sleeve		1
7	GB/T 819	Screw	M5X12	8
8	C6266A-07-38	Pressure Plate		1
9	C6266A-07-37	Oil Scraper		1
10	GB/T 77	Screw	M8×30	1
11	GB/T 308	Steel Ball	D6	2
12	GB/T 70	Screw	M12×45	3
13	C6266A-07-20	Turning Mechanism		1
13	CQ6280-07-20	Turning Mechanism		1
14	C6266A-07-19	T-Slotted Nut		3
15	RUN6141-103103	Central Axis		1
16	GB/T 70	Screw	M6X30	2
17	GB/T 879	Pin	D4X30	2
18	GB/T 308	Steel Ball	D8	10
19	GB2089	Compression Spring	1X6X15	3
20	CD6236-07-05	Handle	Shared part	1
21	C6266A-07-33	Cushion Block		1
22	GB/T 78	Screw	M5×25	1
23	C6266A-07-47	Screw		1
24	GB/T 70	Screw	M5X20	2
25	GB/T 301	Thrust Ball Bearing	51102	1
26	C6266A-07-49	Graduated Ring		1
27	C6266A-07-51	Handwheel		1
28	CD6236-07-39	Handle Casing	Shared part	1
29	CD6236-07-40	Screw	Shared part	1
30	C6266A-07-32	Locking Screw		1
31	C6266A-07-46	Small Lead Screw		1
32	GB/T 1096	Key	3X18	1
33	GB/T 301	Thrust Ball Bearing	51102	1
34		Oil Retaining Bearing	d15XD17X13	1
35	GB2089	Compression Spring	1X6X12	2
36	C6266A-07-50	Graduated Sleeve		1
37	GB/T 70	Screw	M6X12	3
38	GB/T 301	Thrust Ball Bearing	51206	1
39	C6266A-07-42	Adjusting Shim		1

No	Part No.	Name	Specification	Qty.
40	C6266A-07-43	Clamping Nut		1
41	C6266A-07-22	Turret Slide		1
42	GB/T 1155	Oil Cup 6	D=6	7
43	C6266A-07-45	Central Axis		1
44	C6266A-07-23	Square Tool Post		1
45	GB/T 119	Cylindrical Pin	D4×20	1
46	C6266A-07-24	Tool Post Handle		1
47	C6266A-07-44	Pin Roll		3
48	GB77	Screw	M8×16	3
49	C6266A-07-27	Pressure Plate		1
50	C6266A-07-26	Oil Scraper		1
51	C6266A-07-62	Rating Plate		1
52	C6266A-07-19	T-Slotted Nut		3
53	C6266A-07-04	Cross Slide		1
53	CQ6280-07-77	Cross Slide		1
54	GB/T 79	Screw	M8×30	1
55	GB/T 70	Screw	M6×35	3
56	C6266A-07-63	Protective Hood		1
56	CQ6280-07-78	Protective Hood		1
57	GB/T 70	Screw	M5×8	3
58	GB/T 80	Screw	M6×8	3
59	C6266A-07-18	Gib-Headed Key		1
60	GB13806A	Screw	M3X5	2
61	RUN6246-103036	Adjusting Screw	Shared Part	5
62	C6266A-07-72	Cross Slide Gibs		1
63	C6266A-07-16	Screw	T=5	1
64	C6266A-07-15	Taper Wedge		1
65	C6266A-07-06	Middle Lead Screw		1
65	C6266A-07-06Y	Middle Lead Screw		1
65	CQ6280-07-06	Middle Lead Screw		1
65	CQ6280-07-06Y	Middle Lead Screw		1
66	C6266A-07-14	Shim		1
67	GB/T 4663	Cylindrical Roller	81102	2
68		Oil-Retaining Bearing	d15XD17×22	1
69	C6266A-07-05	Rear Support Bracket		1
69	CQ6280-07-05	Rear Support Bracket		1
70	GB/T 70	Screw	M8×30	4
71	GB/T 118	Pin	D6X45	2
72	C6266A-07-08	Shim		1
73	C6266A-07-07	Screw Cap	M15×1.5	1

No	Part No.	Name	Specification	Qty.
74	C6266A-07-13	Sheath		1
75	C6266A-07-36A	Handle Module		1
76	GB/T 119	Cylindrical Pin	D3×12	1
77	GB/T 879	Pin	D3×10	1
78	C6266A-07-32	Locking Screw		1
79	C6266A-07-33	Cushion Block		1
80	GB/T 70	Screw	M6×16	1
81	C6266A-07-30	Graduated Ring		1
82	GB/T68	Screw M5 X 8	M5×8	3
83	C6266A-07-31	Graduated Sleeve		1
84	GB/T 1155	Oil Cup 6	D=6	1
85	GB1096-79	Key	5×18	1
86		Oil Retaining Bearing	d32XD36X35	2
87	GB/T 119	Cylindrical Pin	D6×30	1
88	C6266A-07-35	Locking Screw		1
89	GB/T 308	Steel Ball	D6	2
90	C6266A-07-34A	Handwheel		1
91	GB/T 118	Pin	D8X60	2
92	C6266A-07-61	Pare Off The Oil Plank		1
93	GB/T 301	Thrust Ball Bearing	51104	2
94	C6266A-07-28	Baffle Sheet		1
95	GB/T 70	Screw	M8×25	2
96	C6266A-07-02	Pare Off The Oil Plank		1
97	C6266A-07-57	Handwheel		1
97	CQ6280-07-57	Handwheel		1
98	GB/T 78	Screw	M5×25	1
99	C6266A-07-29-2	Pinion		1
100	C6266A-07-29-1	Sheath		1
100	CQ6280-07-29-1	Sheath		1
101	GB/T 70	Screw	M10×60	5
102	RUN6246-103031-1	Rating Plate	Shared part	1
103	RUN6246-103031	Oil Plug	Shared part	1
104	GB1992A1	Saucer Spring	18X9.2X1X1.4	3
105	GB/T 119	Cylindrical Pin	D3X12	1
106	GB/T 119	Cylindrical Pin	D6X14	1
107	C6266A-07-55	Cap		2
107	CQ6280-07-55	Cap		2
108	C6266A-07-56	Unloading Bracket		2
109	GB278-89	Ball Bearing	80016	2
110	RUN6246-103077	Braking Tightly Screw	Shared part	1

No	Part No.	Name	Specification	Qty.
111	C6266A-07-60	Front Pressure Plate		2
112	GB70-85	Hexagon Socket Cap Set Screw	M8X25	4
113	C6266A-07-53	Pillar Screw Bolt		1
114	C6266A-07-52	Saddle Locking Block		1
115	C6266A-07-59	Screw		1
116	C6266A-07-58	Pressure Plate		2
117	C6266A-07-12	Rear Pressure Plate Gibs		1
118	GB/T 68	Screw	M4×6	5
119	RUN6141-103016-1	Gibbed Baffle		2
120	GB/T 70	Screw	M8×30	5
121	C6266A-07-10	Rear Pressure Plate		1
122	GB/T 818	Screws	M5×12	12
123	C6266A-07-01	Pare Off The Oil Plank		2
124	C6266A-07-09	Pare Off The Oil Plank		1
125	C6266A-07-03	Cross Slide		1
125	CQ6280-07-03	Cross Slide		1
126	GB/T 70	Screw	M5×12	2
127	GB/T68	Screw	M5×10	2
128	RUN6246-103065	Spring		1
129	GB/T 1235	O-Ring	13×1.9	1
130	RUN6246-103064	Piston Rod		1
131	C6266A-07-66	Body Pump		1
132	GB308-84	Steel Ball	φ 5	2
133	GB2089-80	Spring	0.5×4.5×16	1
134	GB1235-76	O-Ring	16×2.4	1
135	RUN6246-103070	Oil Plug		1
136	RUN6246-103067	Plug		1
137	C6266A-07-65	Plate		1
138	C6266A-07-64	Bottom Board		1
139	GB1235-76	O-Ring	32×3.1	1
140	JC1	Tube Fitting	Z 1/8"× φ 6	1
141	C6266A-07-63	Brass Tube	φ 6×280	1
142	RUN6246-103071	Tube Fitting		1
143	RUN6246-103072	Nut		1
144	RUN6246-103073-2	Sleeve		1
145	RUN6246-103073-1	One Way Valve Ass		1
146	C6266A-07-81	Vitta welding		1
147	JC1	Tube Fitting	Z 1/8"× φ 4	3

Apron

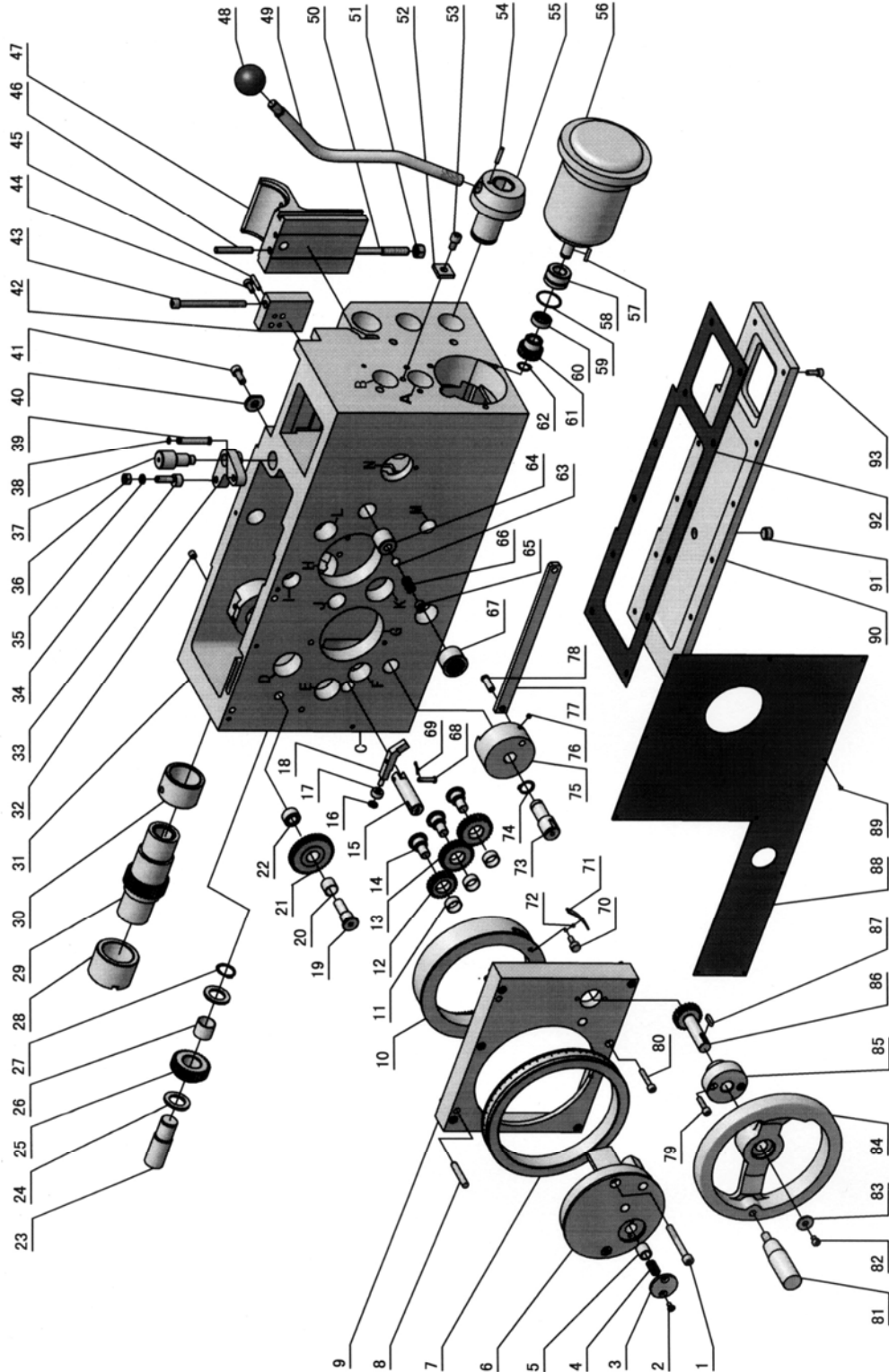

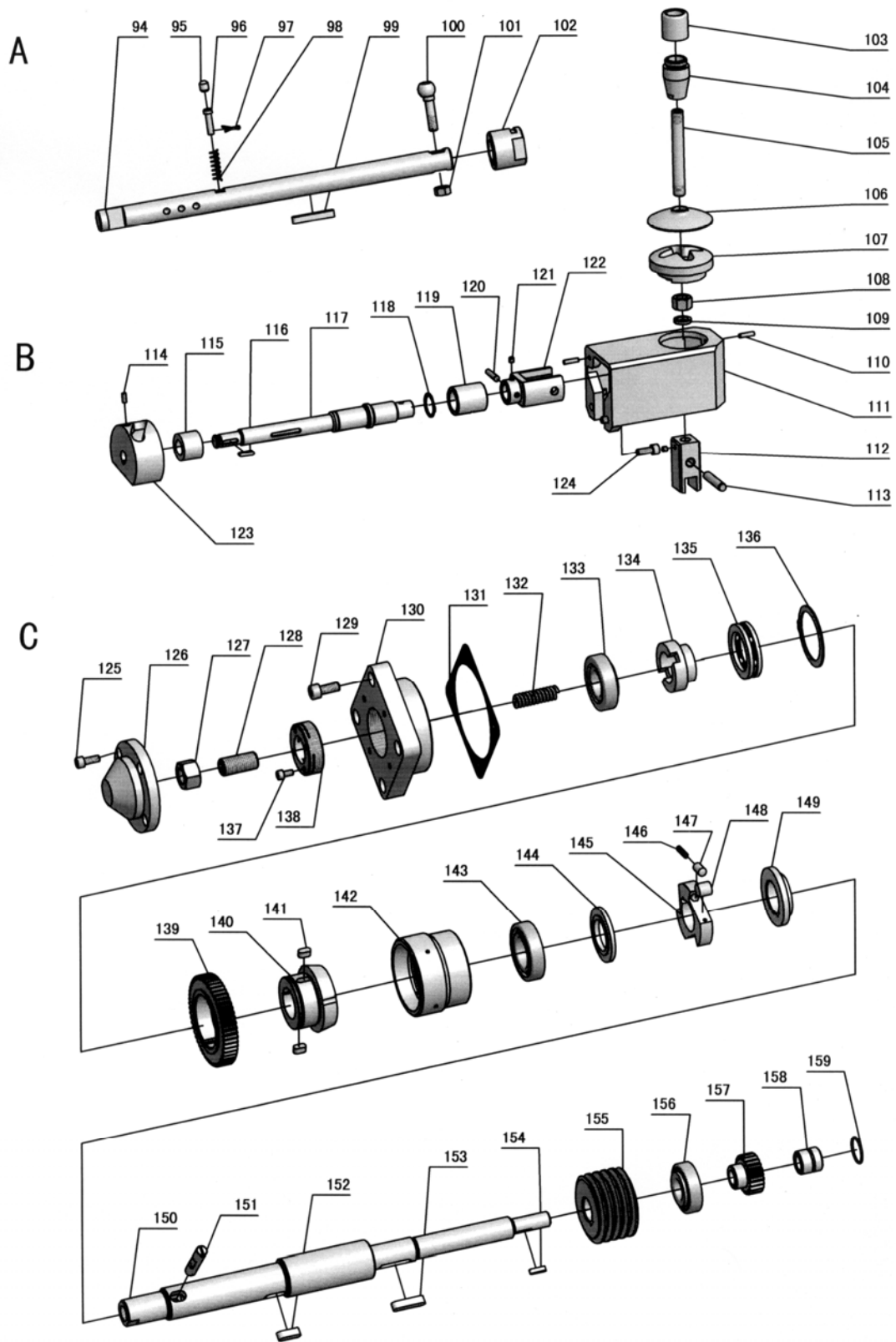

D

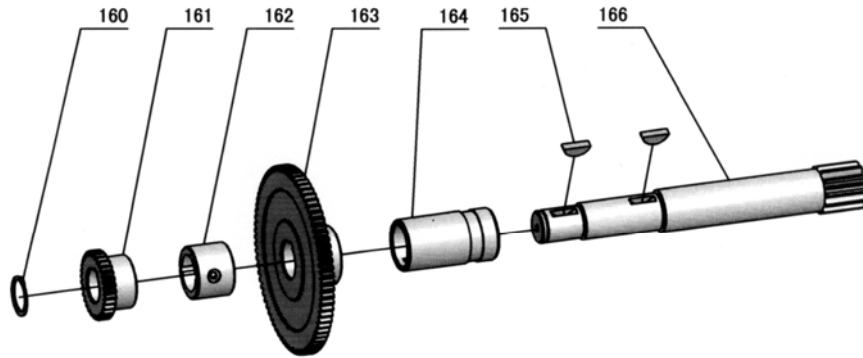

E

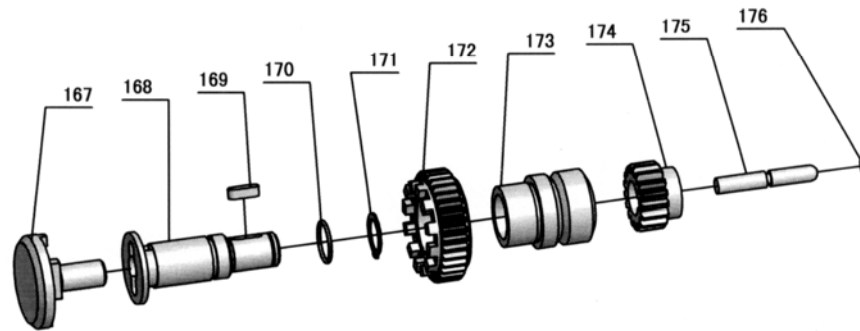

F

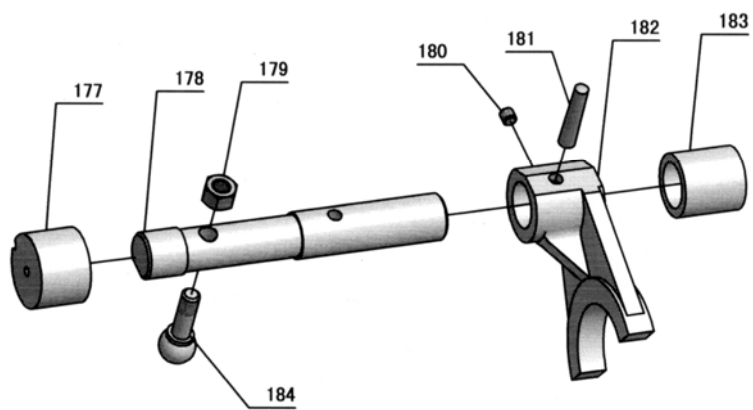

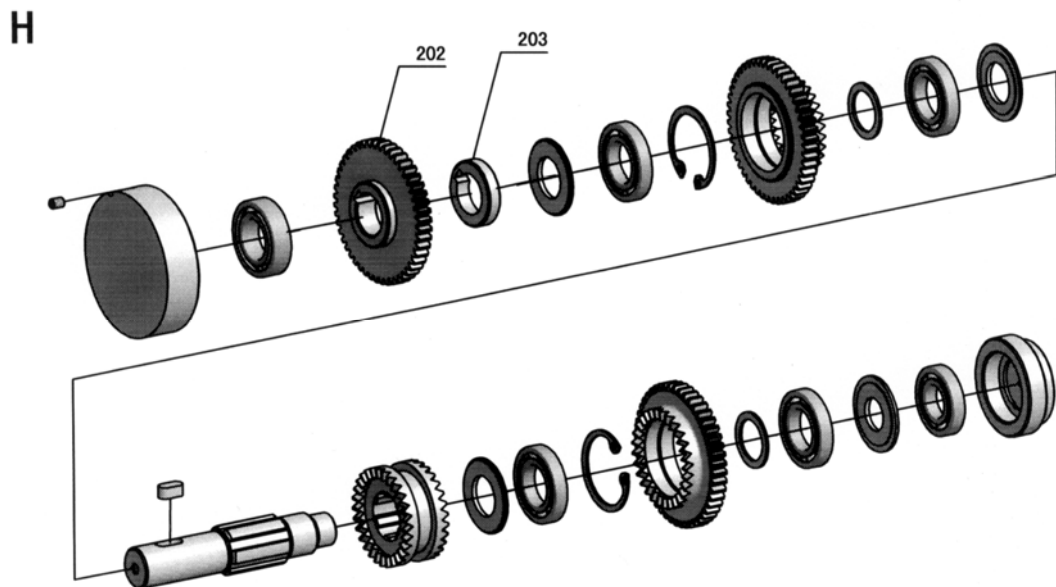
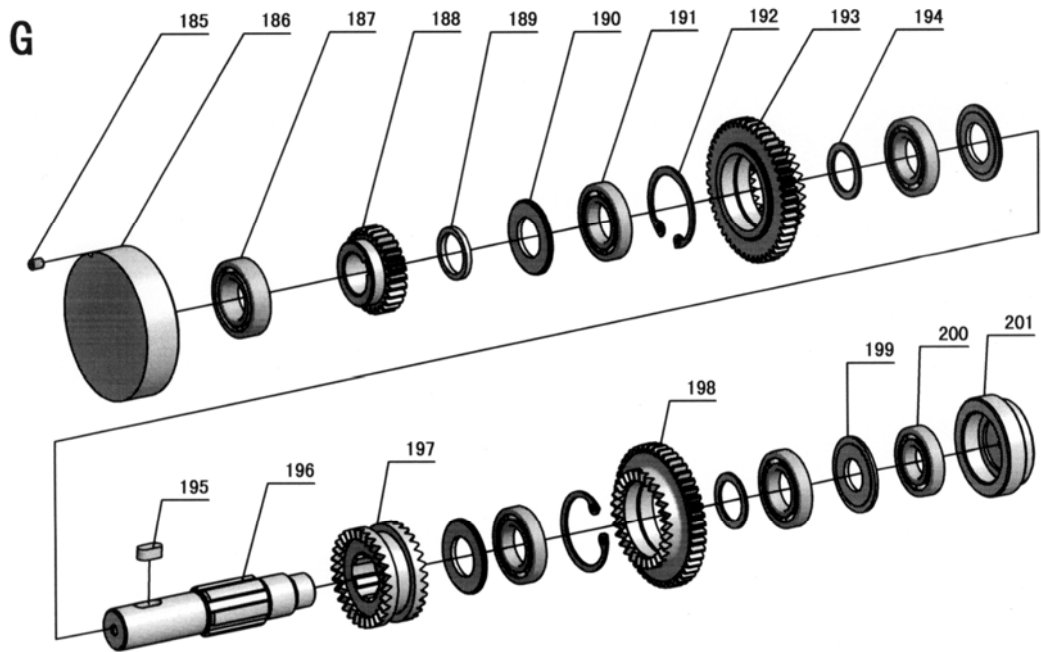

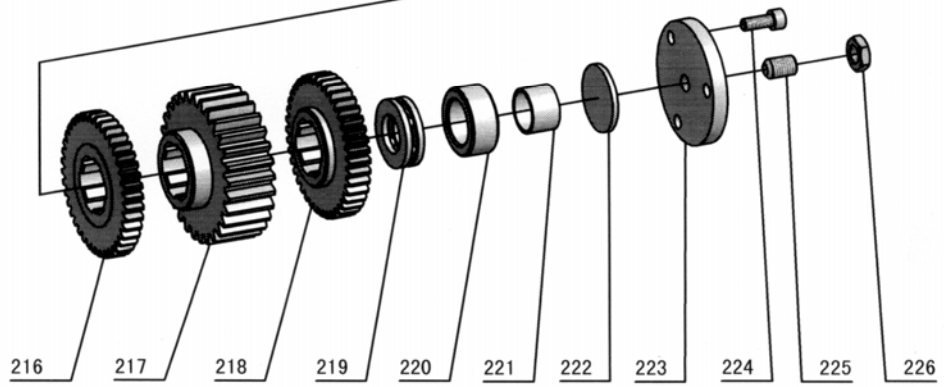
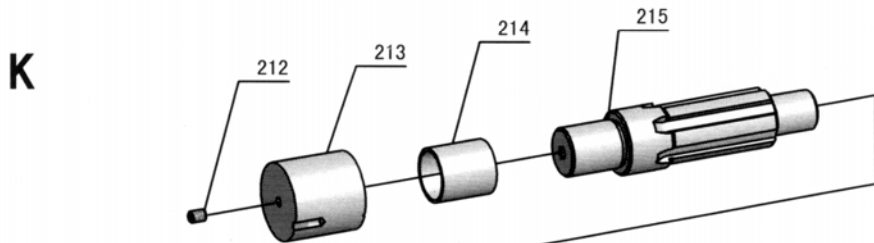
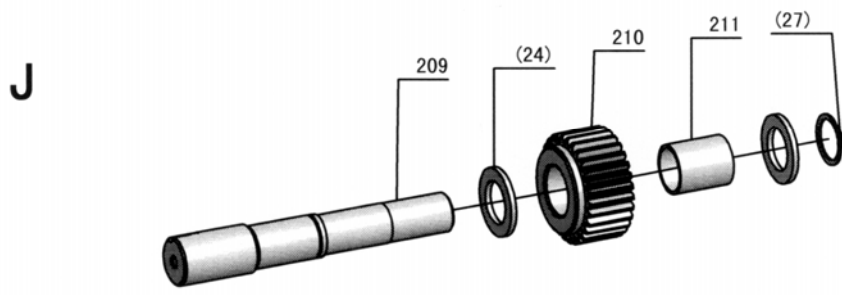
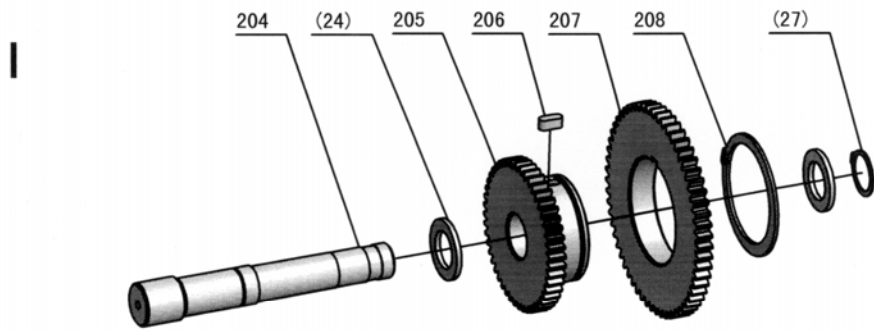

L

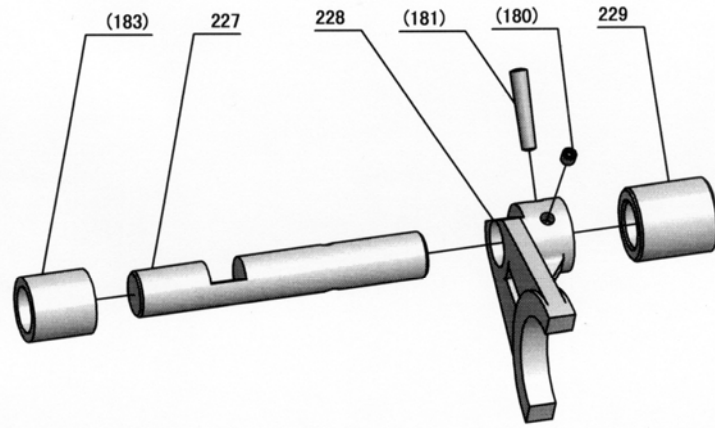

M

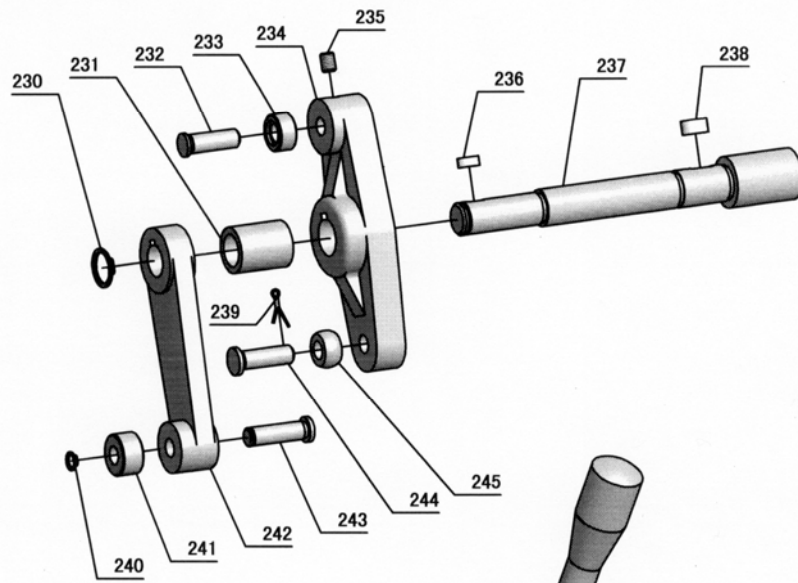

N

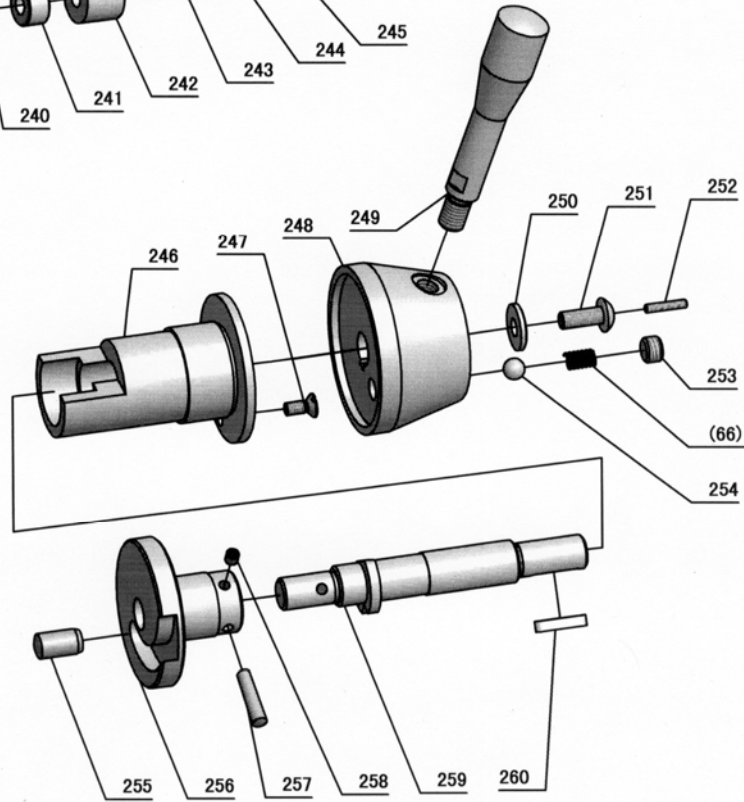

No.	Part No.	Name	Specifications	Qty.
1	GB70-85	Screw	M8×65	2
2	GB68-85	Screw	M5×10	2
3	C6266A-06-040	End Cover		1
4	C6266A-06-038	Pressure Spring		1
5	C6266A-06-039	Top Cover		1
6	C6266A-06-171	Eccentric Disk		1
7	C6266A-06-030	Graduated Ring		1
8	GB119-86	Type A Cylindrical Pin	8×45	2
9	C6266A-06-170	Cover		1
10	C6266A-06-031	Inside-Engaged Gear		1
11	SF-1(DU)	Lubrication Gear	C/SF1810	1
12	C6266A-06-166	Gear	M1.5, Z29	2
13	C6266A-06-167	Gear	M1.5, Z24	1
14	C6266A-06-165	Shaft		3
15	C6266A-06-026	Shaft		1
16	GB95-85	Washer	6	1
17	C6266A-06-024	Bulb		1
18	C6266A-06-023	Transmission Fork		1
19	C6266A-06-046	Shaft		1
20	SF-1(DU)	Lubrication Gear	C/SF1615	1
21	C6266A-06-047	Gear Wheel		1
22	C6266A-06-045	Spacing Collar		1
23	C6266A-06-102	Shaft		1
24	C6266A-06-056	Spacing Collar		6
25	C6266A-06-103	Gear Wheel		1
26	SF-1(DU)	Lubrication Gear	C/SF2220	1
27	GB894.1-86	Circlip For Shaft	22	3
28	C6266A-06-104	Sheath		1
29	C6266A-06-105	Gear Wheel		1
30	C6266A-06-106	Sheath		1
31	C6266A-06-001	Apron Body		1
32	GB80-85	Screw	M8×10	2
33	C6266A-06-081	Transmission Fork		1
34	C6266A-06-082	Eccentric Pin		1
35	GB93-76	Washer	8	1
36	GB6171-86	Hexagon Nut Type 1	M8×1	1
37	C6266A-06-083	Staff		1
38	GB894.1-86	Circlip For Shaft	8	1
39	C6266A-06-138	Pin		1
40	C6266A-06-005	Pressing Ring		2

No.	Part No.	Name	Specifications	Qty.
41	GB 70-85	Screw	M8×20	7
42	C6266A-06-125	Limit Block		1
43	GB70-85	Screw	M8×100	1
44	GB70-85	Screw	M6×14	2
45	GB879-86	Pin	5×24	2
46	GB119-86	Cylindrical Pin Type A	8×55	1
47	C6266A-06-123	Nut Base		1
48	HY8311.1, A	Handle Bulb	M12×40	1
49	C6266A-06-147	Handle Lever		1
50	C6266A-06-122	Screw		1
51	GB41-86	Hexagon Nut Type 1	M10	1
52	C6266A-06-088	Baffle		1
53	GB70-85	Screw	M8×14	1
54	GB879-86	Pin	5×24	1
55	C6266A-06-149	Handle Apparatus		1
56	YS	Motor	YSS2-5634	1
57	GB1096-79	Key	C4×18	1
58	C6266A-06-090	Sheath		1
59	GB/T3452.1-1992	O-Ring	28×1.80	1
60	GB/T13871-1992	Oil Seal	FB15×25×7	1
61	C6266A-06-091	Gear Wheel		1
62	GB894.1-86	Circlip For Shaft	14	1
63	GB308-89	Steel Ball	φ 10	1
64	C6266A-06-155	Sheath		1
65	GB77-85	Screw	M12×8	1
66	C6266A-06-120	Pressure Spring		2
67	R51-5A	Oil Sight Glass	20	1
68	C6266A-06-022	Pin		1
69	GB91-86	Cotter Pin	2×10	1
70	C6266A-06-048	Hand-Tightened Screw		1
71	C6266A-06-049	Leaf Spring		1
72	GB308-89	Steel Ball	φ 4	2
73	C6266A-06-027	Shaft		1
74	GB894.1-86	Circlip For Shaft	17	1
75	C6266A-06-025	Cam		1
76	GB77-85	Screw	M5×4	1
77	C6266A-06-142	Yoke Plate		1
78	C6266A-06-128	Pin		1
79	GB70-85	Screw	M6×25	2
80	GB70-85	Screw	M6×35	6

No.	Part No.	Name	Specifications	Qty.
81	GB4141.5-84	Turning Handle	M10	1
82	GB65-85	Screw	M6×8	1
83	C6266A-06-035	Washer		1
84	C6266A-06-034	Handwheel		1
85	C6266A-06-169	Sheath		1
86	C6266A-06-168	Pinion		1
87	GB1096-79	Key	5×18	1
88	C6266A-06-162	Rating Plate Of Apron		1
89	GB827-86	Rivet For Rating Plate	2.5×6	10
90	C6266A-06-151	Apron Underplate		1
91	GB77-85	Screw	M16×10	1
92	C6266A-06-150	Paper Washer		1
93	GB70-85	Screw	M6×16	12
94	C6266A-06-073	Shaft		1
95	C6266A-06-077	Round Head Pin		1
96	C6266A-06-078	Pin		1
97	GB91-86	Cotter Pin	2×10	1
98	C6266A-06-076	Pressure Spring		1
99	GB1096-79	Key	6×40	1
100	C6266A-06-072	Spherical Pin		1
101	GB6171-86	Hexagon Nut Type 1	M8×1	1
102	C6266A-06-074	Sheath		1
103	C6266A-06-065A	Handle Cap		1
104	C6266A-06-066A	Handle Apparatus		1
105	C6266A-06-067	Handle Lever		1
106	C6266A-06-068	Dust Cap		1
107	C6266A-06-069	Cross Cover		1
108	GB6171-86	Hexagon Nut Type 1	M14×1.5	1
109	GB93-87	Spring Washer	14	1
110	GB119-86	Type A Cylindrical Pin	5×20	2
111	C6266A-06-071	Hood		1
112	C6266A-06-070	Handle Apparatus		1
113	GB119-86	Type A Cylindrical Pin	10×50	1
114	GB78-85	Screw	M5×12	1
115	C6266A-06-085	Sheath		1
116	GB1096-79	Key	5×20	1
117	C6266A-06-087	Shaft		1
118	GB894.1-86	Circlip For Shaft	25	1
119	C6266A-06-086	Sheath		1
120	GB117-86	Type A Tapered Cottar	6×30	1

No.	Part No.	Name	Specifications	Qty.
121	GB77-85	Screw	M6×6	1
122	C6266A-06-089	Joint		1
123	C6266A-06-084	Cam		1
124	GB70-85	Screw	M8×20	2
125	GB70-85	Screw	M6×16	4
126	C6266A-06-098	Cover		1
127	GB6171-86	Hexagon Nut Type 1	M16×1.5	1
128	GB77-85	Screw	M16×35	1
129	GB70-85	Screw	M8×20	4
130	C6266A-06-097	Bearing Cap		1
131	C6266A-06-101	Paper Washer		1
132	C6266A-06-108	Pressure Spring		1
133	GB/T 297-94	Conical Roller Bearing	30205	1
134	C6266A-06-109	Sheath		1
135	GB/T 301-1995	Thrust Ball Bearing	51107	1
136	GB894.1-86	Circlip For Shaft	50	1
137	GB70-85	Screw	M5×10	2
138	C6266A-06-100	Nut		1
139	C6266A-06-096	Gear Wheel		1
140	C6266A-06-110	Cone Friction Clutch		1
141	GB1096-79	Key	6×12	2
142	C6266A-06-095	Clutch Sleeve		1
143	GB/T 292-94	Angular Contact Bearing	7006AC	1
144	C6266A-06-094	Spacing Collar		1
145	C6266A-06-114	Star Body		1
146	C6266A-06-116	Pressure Spring		3
147	C6266A-06-115	Adapter Sleeve		3
148	GB309-78	Short Cylindrical Roller	12×12	3
149	C6266A-06-093	Spacing Collar		1
150	C6266A-06-112	Shaft		1
151	C6266A-06-107	Stop Dog		1
152	GB1096-79	Key	8×22	1
153	GB1096-79	Key	8×32	1
154	GB1096-79	Key	4×16	1
155	C6266A-06-092	Worm		1
156	GB/T 297-94	Conical Roller Bearing	30204	1
157	C6266A-06-111	Shaft		1
158	C6266A-06-113	End Cover		1
159	GB/T 3452.1-1992	O-Ring	18×1.80	1
160	GB894.1-86	Circlip For Shaft	25	1

No.	Part No.	Name	Specifications	Qty.
161	C6266A-06-044	Gear Wheel		1
162	C6266A-06-018	Sheath		1
163	C6266A-06-017	Gear Wheel		1
164	C6266A-06-016	Sheath		1
165	GB 1099-79	Semicircular Key	6×9×22	2
166	C6266A-06-015	Pinion		1
167	C6266A-06-041	Coupler		1
168	C6266A-06-020	Shaft		1
169	GB1096-79	Key	5×16	1
170	GB/T 3452.1-1992	O-Ring	18×1.80	1
171	GB894.1-86	Circlip For Shaft	17	1
172	C6266A-06-042	Gear Wheel		1
173	C6266A-06-043	Sheath		1
174	C6266A-06-021	Gear Wheel		1
175	C6266A-06-019	Mandrel		1
176	GB/T 3452.1-1992	O-Ring	4.5×1.80	1
177	C6266A-06-145	End Cover		1
178	C6266A-06-141	Shaft		1
179	GB41-86	Hexagon Nut Type 1	M8	1
180	GB77-85	Screw	M6×6	2
181	GB117-86	Type A Tapered Cottar	6×35	2
182	C6266A-06-079	Transmission Fork		1
183	C6266A-06-137	Sheath		2
184	C6266A-06-144	Ball Pin		1
185	GB77-85	Screw	M6×8	8
186	C6266A-06-051	Bearing Sleeve		2
187	GB/T 278-89	Deep Groove Ball Bearing	80105	2
188	C6266A-06-050	Gear Wheel		1
189	C6266A-06-063	Spacing Collar		1
190	C6266A-06-163	Spacing Collar		6
191	GB/T 278-89	Ball Bearing	80105	8
192	GB 893.2-86	Snap Ring	47	4
193	C6266A-06-060	Gear Wheel		2
194	C6266A-06-164	Spacing Collar		4
195	GB1096-79	Key	8×16	2
196	C6266A-06-058	Shaft		2
197	C6266A-06-014	Coupler		2
198	C6266A-06-003	Gear Wheel		2
199	C6266A-06-013	Spacing Collar		2
200	GB/T 278-89	Ball Bearing	80104	2

No.	Part No.	Name	Specifications	Qty.
201	C6266A-06-004	Bearing Sleeve		2
202	C6266A-06-059	Gear Wheel		1
203	C6266A-06-064	Spacing Collar		1
204	C6266A-06-002	Shaft		1
205	C6266A-06-061	Gear Wheel		1
206	GB1096-79	Key	6×14	1
207	C6266A-06-062	Gear Wheel		1
208	GB894.1-86	Circlip For Shaft	60	1
209	C6266A-06-006	Shaft		1
210	C6266A-06-057	Gear Wheel		1
211	SF-1 (DU)	Lubrication Bearing	C/SF2230	1
212	GB77-85	Screw	M6×8	1
213	C6266A-06-052	End Cover		1
214	SF-1 (DU)	Lubrication Bearing	C/SF2530	1
215	C6266A-06-053	Shaft		1
216	C6266A-06-054	Gear Wheel		1
217	C6266A-06-055	Helical Gear		1
218	C6266A-06-011	Gear Wheel		1
219	GB/T 301-1995	Thrust Ball Bearing	51104	1
220	C6266A-06-010	Sheath		1
221	SF-1 (DU)	Bearing	C/SF2015	1
222	C6266A-06-009	Shim		1
223	C6266A-06-007	Flange		1
224	GB70-85	Screw	M6×16	3
225	C6266A-06-008	Screw		1
226	GB 6173-86	Hexagonal Thin Nut	M10×1	1
227	C6266A-06-140	Shaft		1
228	C6266A-06-080	Transmission Fork		1
229	C6266A-06-126	End Cover		2
230	GB894.1-86	Circlip For Shaft	14	1
231	C6266A-06-133	Sheath		1
232	C6266A-06-128	Pin		1
233	C6266A-06-127	Bulb		1
234	C6266A-06-129	Shifting Rod		1
235	GB77-85	Screw	M6×8	1
236	GB1096-79	Key	4×10	1
237	C6266A-06-130	Shaft		1
238	GB1096-79	Key	5×12	1
239	GB91-86	Cotter Pin	2×10	1
240	GB894.1-86	Circlip For Shaft	6	1

No.	Part No.	Name	Specifications	Qty.
241	C6266A-06-136	Roller Head		1
242	C6266A-06-134	Swinging Arm		1
243	C6266A-06-135	Pin		1
244	C6266A-06-132	Pin		1
245	C6266A-06-131	Roller Head		1
246	C6266A-06-121	Sheath		1
247	GB68-85	Screw	M6×14	3
248	C6266A-06-119	Handle Apparatus		1
249	C6266A-04-142	Lever		1
250	RUN6246-101070-1	Washer		1
251	RUN6246-101088	Round Head Screw		1
252	GB77-85	Screw	M4×20	1
253	GB77-85	Screw	M12×8	1
254	GB308-89	Steel Ball	φ 10	1
255	GB119-86	Cylindrical Pin Type A	12×22	1
256	C6266A-06-124	Split Nut Control Plate		1
257	GB117-86	Type A Tapered Cottar	6×30	1
258	GB77-85	Screw	M6×6	1
259	C6266A-06-075	Shaft		1
260	GB1096-79	Key	5×25	1

Tailstock

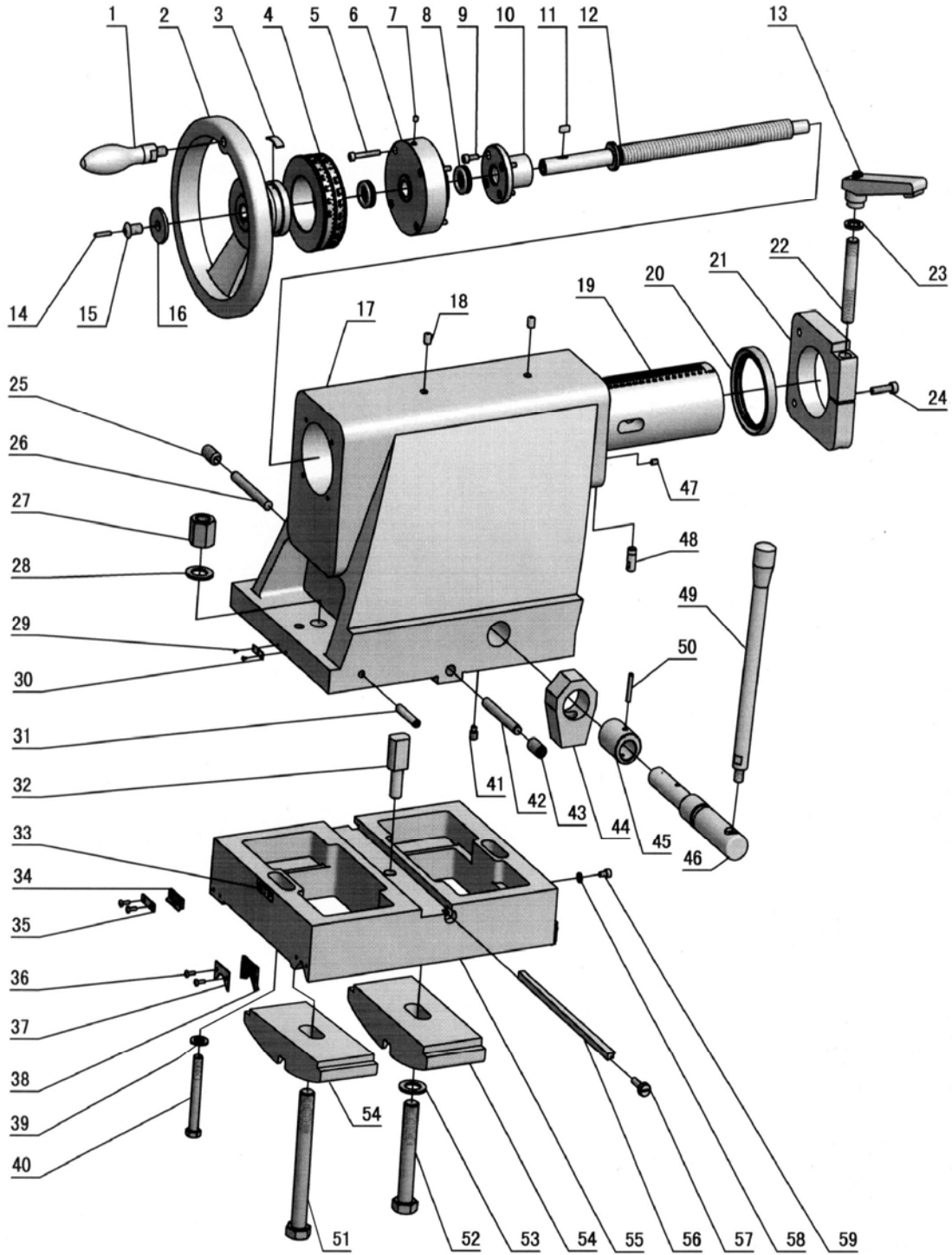

No.	Part No.	Name	Specifications	Qty.
1	JB/T7270.6	Curved-Surface	BM12×100	1
2	C6266-08-07	Handwheel		1
3	Q67-4-33	Spring	100	1
4	C6266-08-08	Graduation Ring		1
5	GB/T70.1	Screw	M6×40	4
6	C6266-08-09	Flange		1
7	GB/T1155	Oil Cup	6	1
8	GB/T301	Thrust Ball Bearing	20×35×10	2
9	GB/T70	Screw	M6×16	4
10	C6246B-105005	Screw Cap	Shared part	1
11	GB/T1096	Key	6×15	1
12	C6266-08-10	Feeding Lead Screw		1
13	Z52-2	Adjustable Fixed Handle	A-M16×110	1
14	GB/T80	Screw	M5×25	1
15	C6266-08-18	Screw		1
16	C6266-08-19	Washer		1
17	C6266-08-12	Tailstock		1
18	GB/T1155	Oil Cup	10	2
19	C6266-08-11	Quill		1
20	HG4-692-67	Oil Seal	PD90×110×12	1
21	C6266-08-13	Locking Block		1
22	C6266-08-06	Screw Bolt		1
23	C6266-08-05	Washer		1
24	GB/T70	Screw	M8×30	2
25	GB/T80	Screw	M16×30	1
26	GB/T119.2	Pin	12×100	1
27	GB/T56	Nut	M20	1
28	GB/T95	Washer	20	1
29	GB/T827	Rivet	2×5	4
30	RUN460-105031	Rating Plate Of Tailstock	Shared part	1
31	RUN460-105007	Brake Screw Bolt	Shared part	1
32	C6266-08-16	Adjusting Piece		1
33	RUN460-105032	Rating Plate Of Tailstock	Shared part	1
34	C6251A-08-09	Dustproof Oil Seal	Shared part	2
35	C6251A-08-08	Fixing Piece	Shared part	2
36	GB/T818	Screw	M4×12	8
37	C6266-08-03	Fixing Piece		2
38	C6266-08-04	Dustproof Oil Seal		2
39	GB/T95	Washer	12	2
40	GB/T5782	Screw Bolt	M12×100	2

No.	Part No.	Name	Specifications	Qty.
41	GB/T79	Screw	M10×16	1
42	GB/T119.2	Pin	12×100	1
43	GB/T80	Screw	M16×30	1
44	RUN460-105018	Supporting Bracket	Shared part	1
45	RUN460-105028	Eccentric Block	Shared part	1
46	C6266-08-14	Brake Screw Bolt		1
47	GB/T80	Screw	M6×10	1
48	C6246B-105030	Limit Block	Shared part	1
49	RUN460-105006-1	Screw Bolt	Shared part	1
50	GB/T879.1	Pin	6×36	1
51	GB/T37	Screw Bolt	M20×180	1
52	GB/T5782	Screw Bolt	M20×130	1
53	GB/T95	Washer	20	1
54	C6266-08-17	Brake Block		2
55	C6266-08-15	Base Frame		1
55	CQ6280-08-15	Base Frame		1
56	C6266-08-02	Gibs		1
57	RUN460-105020	Adjusting Screw		2
58	GB/T95	Washer	6	1
59	GB/T70	Screw	M6×10	1

Bed Assembly

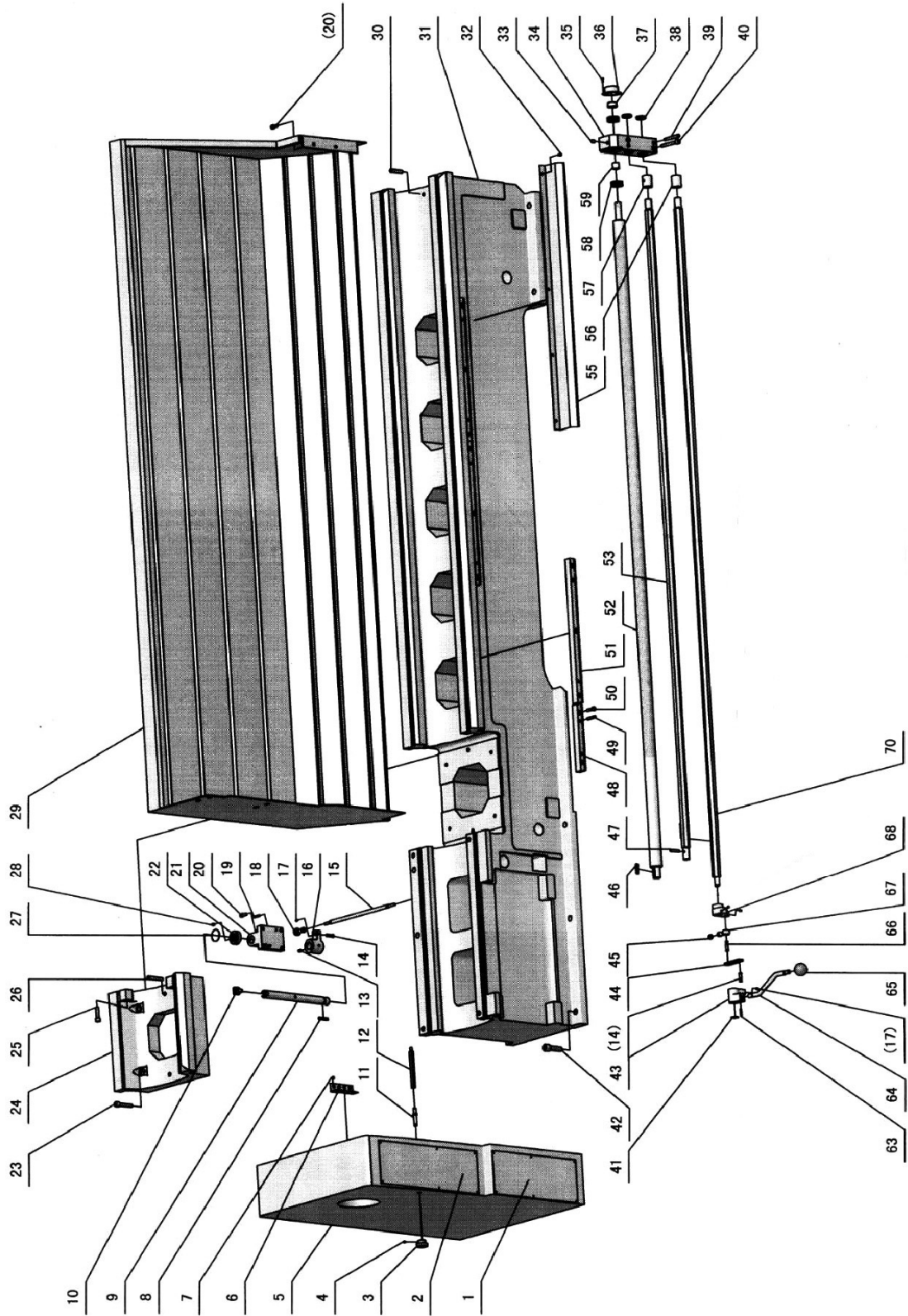

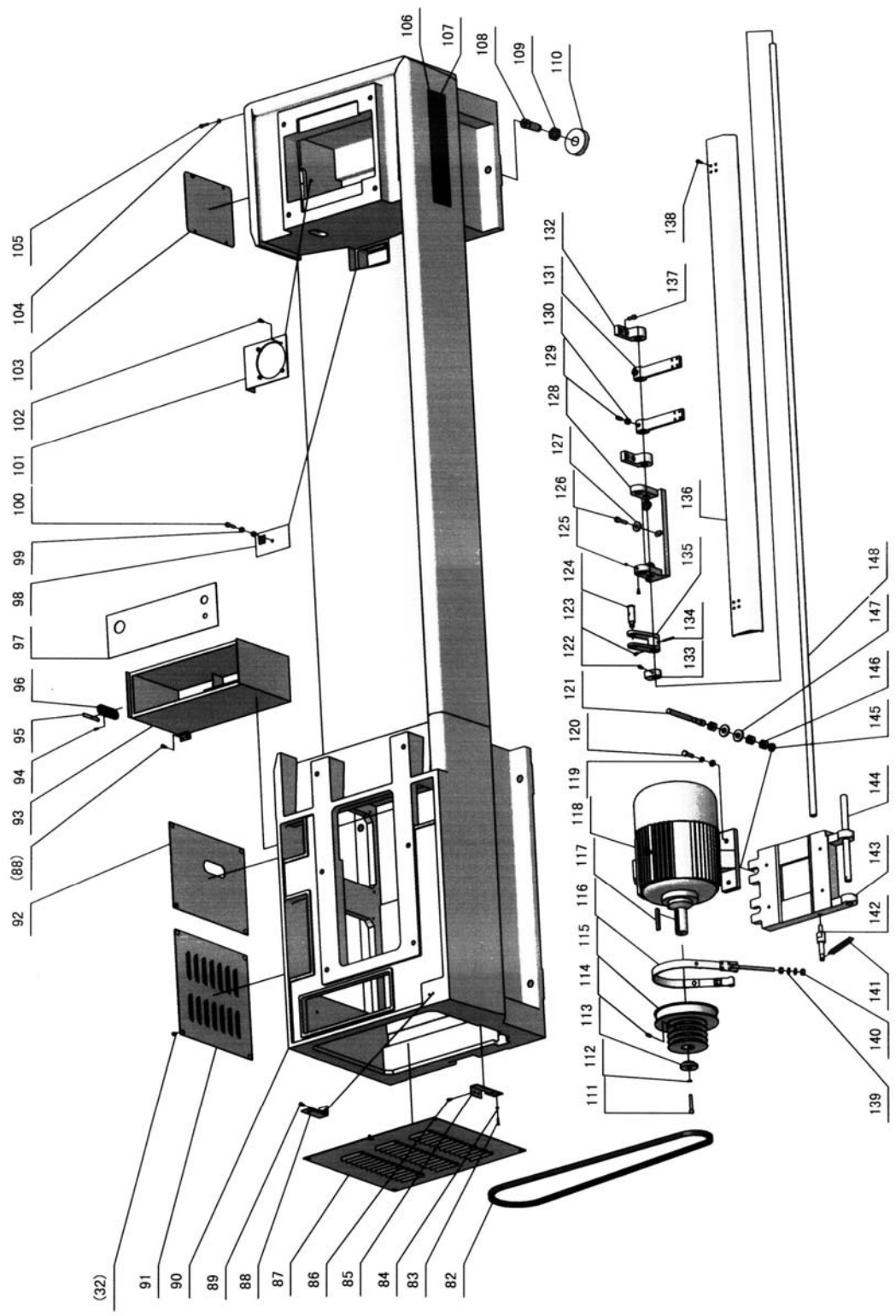

No.	Part No.	Name	Specifications	Qty.
1	C6266A-05-90	Rating Plate		1
2	C6266A-05-91	Rating Plate		1
2	C6266A-05-91Y	Rating Plate		1
2	CQ6280-05-91	Rating Plate		1
2	CQ6280-05-91Y	Rating Plate		1
3	RUN6246-108073	Nut		1
4	GB79-85	Screw		1
5	C6266A-20-23	Cover-End		1
5	C6266A-20-23-1	Cover-End		1
5	CQ6280-20-23	Cover-End		1
5	CQ6280-20-23-1	Cover-End		1
6	GB7277-87	Hinge	100	2
7	GB68-85	Screw	M5×10	16
8	GB1096-79	Round-Head Ordinary Flat Key	A6X40	1
9	C6266A-01-49	Connecting Rod		1
10	C6266A-01-50	Crosshead Shoe		1
11	RUN6246-108074	Screw		1
12	C6266A-05-12	Screw		1
13	GB78-85	Screw	M8X10	1
14	C6266A-01-53	Pin		2
15	C6266A-01-55	Connecting Rod		1
16	C6266A-01-48	Swinging Arm		1
17	GB80-85	Screw	M6X8	1
18		Knuckle Bearing	M8Levorotationar	1
19	GB119-86	Ordinary Cylindrical Pin	6X30	2
20	GB70-85	Screw	M8X20	4
21	C6266A-01-46	Support Abutment		1
22	C6266A-01-47	Shaft Sleeve		1
23	GB70-85	Screw	M12×60	4
24	C6266A-01-02	Saddle		1
25	GB70-85	Screw	M10X40	2
26	GB118-86	Tapered Cottar	10×70	2
	GB118-86	Tapered Cottar	10×45	2
27	GB921-86	Steel Wire Locking Collar	D38Xd1	1
28	GB71-85	Screw	M8X10	1
29	C6266A-01-60	Welding Drawing (2000)		1
29	C6266A-01-60-1	Welding Drawing (3000)		1
29	C6266A-01-60-3	Welding Drawing (1500)		1
29	CQ6280-01-60	Welding Drawing (2000)		1
29	CQ6280-01-60-1	Welding Drawing (3000)		1

No.	Part No.	Name	Specifications	Qty.
29	CQ6280-01-60-3	Welding Drawing (1500)		1
30	GB878-86	Threaded Cylindrical Pin	M12X50	1
31	C6266A-01-01	Lathe Bed		1
32	GB/T70.2-2000	Screw	M6X10	10
33	RUN6246-106010-4	Plug-Oil Inlet		1
	RUN6246-106010-8	Plate		1
34	C6266A-01-33	Hitching Leg		1
35	GB70-85	Screw	M4X10	2
36	C6266A-01-34	End Cap		1
37	RUN6246-106007	Screw Cap	Shared part	1
38	C6266A-01-37	Hitching Leg Stopper		2
39	GB118-86	Tapered Cottar	8X70	2
40	GB70-85	Screw	M10X80	2
41	GB894.1-86	Circlip For Shaft	20	1
42	GB70-85	Screw	M16×55	12
43	C6266A-01-57	Lever Supporting Abutment		1
44	C6266A-01-56	Connecting Rod		1
45	GB6170-86	Hexagon Nut Type 1	M8	1
46	GB1096-79	Key	C6×36	1
47	C6266A-01-65	Safety Pin		1
48	C6266A-01-44	Rack		1
49	GB879-86	Resilient Cylindrical Pin	8X40	12
50	GB70-85	Hexagon Socket Cap Set Screw	M8X30	17
51	C6266A-01-45	Rack		4
	C6266A-01-77	Rack		1
52	C6266A-01-30	Large Lead Screw		1
53	C6266A-01-31	Feeding Rod		1
55	C6266A-01-29-8	Chip Guard		1
55	C6266A-01-29-9	Chip Guard		2
55	C6266A-01-29-10	Chip Guard		2
55	C6266A-01-29-11	Chip Guard		3
56	C6266A-01-35	Control Lever Casing		1
57	C6266A-01-36	Feeding Lead Screw Casing		1
58	GB301-84	Thrust Ball Bearing	51204	2
59	SF-1	Oil Retaining Bearing	2020	1
63	GB879-86	Resilient Cylindrical Pin	5X24	1
64	C6266A-01-58	Control Lever		1
65	Z16-1	Handle Bulb	M12×40	1
66	C6266A-01-59	Pin		1
67		Knuckle Bearing	M8dextrorotationa	1

No.	Part No.	Name	Specifications	Qty.
68	C6266A-01-54	Control Block		1
70	C6266A-01-32	Control Lever		1
82		V Belt (Type B)	B97"	4
83	GB70-85	Screw	M5×10	2
84	GB6170-86	Hexagon Nut Type 1	M4	2
85	RUN6246-106091	Microswitch Bracket	Shared part	1
86	GB818-85	Screw	M4×20	2
87	C6266A-01-40	Side Cover		1
88	RUN6246-106014	Limited Switch Seat		1
89	GB70-85	Screw	M6×16	12
90	C6266A-01-03-2	Lathe Leg		1
91	C6266A-01-41	Rear Cover		1
92	C6266A-01-42	Rear Cover		1
93	C6266A-01-69	Oil Tank Cover		1
94	GB822-85	Screw	M4X10	4
95	GB3452.1-82	O Ring	50X1.8	1
96	RUN460-104068	Oil Cup	Shared part	1
97	C6266A-01-68	Oil Tank		1
98	RUN6246-106051	Filter Screen		2
99	GB6170-86	Hexagon Nut Type 1	M8	4
100	GB70-85	Screw	M8X30	2
101	C6251A-01-17-5	Cooling Pump Base		1
102	GB70-85	Screw	M6X12	4
103	RUN6246-106033	Pump Hole Cover		2
104	GB97.1-85	Flat Washer	6	2
105	GB70-85	Screw	M6X25	2
106	C6266A-01-70	Rating Plate		1
106	CQ6280-01-70	Rating Plate		1
107	GB818-85	Screw	M3X6	4
108	RUN6246-106069	Cushion Block	Shared part	8
109	GB6173-86	Hexagonal Thin Nut	M24X2	8
110	RUN6246-106029	Leveling Screw	Shared part	8
111	GB70-85	Screw	M8×55	1
112	GB93-87	Spring Washer	8	1
113	RUN6141-106049a	Belt Pulley Washer	Shared part	1
114	GB80-85	Screw	M8×20	1
115	C6266A-01-08	Motor Belt Pulley		1
116	RUN6246-106047	Brake Ribbon	Shared part	1
117	GB1096C-79	Key	10×70	1
118		Motor		1

No.	Part No.	Name	Specifications	Qty.
119	GB93-87	Spring Washer	10	4
120	GB5782-86	Hexagonal Head Screw Bolt	M10X35	4
121	RUN6246-106046	Adjusting Screw	Shared part	2
122	GB70-85	Screw	M6×12	1
123	GB70-85	Screw	M5×10	1
124	RUN6246-106039	Inserted Pin	Shared part	1
125	GB80-85	Screw	M6×8	1
126	GB70-85	Screw	M10×40	3
127	RUN6246-106097	Shim	Shared part	3
128	RUN6246-106041	Motor Plate Bracket	Shared part	1
129	GB79-85	Screw	M10X25	4
130	GB6170-86	Hexagon Nut Type 1	M10	4
131	RUN6246-106042A	Bracket	Shared part	4
132	RUN6246-106036	Carrier		4
133	RUN6246-106037	Cam	Shared part	1
134	GB879-86	Resilient Cylindrical Pin	5×40	1
135	RUN6246-106040	Swinging Arm	Shared part	1
136	C6266A-01-39-2	Brake Pedal		2
137	GB70-85	Screw	M8X20	8
138	GB70-85	Screw	M6X16	16
139	GB97.1-85	Flat Washer	D10	4
140	GB6170-86	Hexagon Nut Type 1	M10	2
141	Q81-3	Spring	3×16×115	1
142	RUN6246-106050	Fixed Pin	Shared part	1
143	RUN6246-106034	Motor Plate	Shared part	1
144	RUN6246-106044	Staff	Shared part	1
145	GB93-87	Spring Washer	16	2
146	GB6170-86	Hexagon Nut Type 1	M16	6
147	RUN6246-106079	Washer	Shared part	4
148	C6266A-01-38-2	Brake Axle		1

C6266A Change gear (Metric)

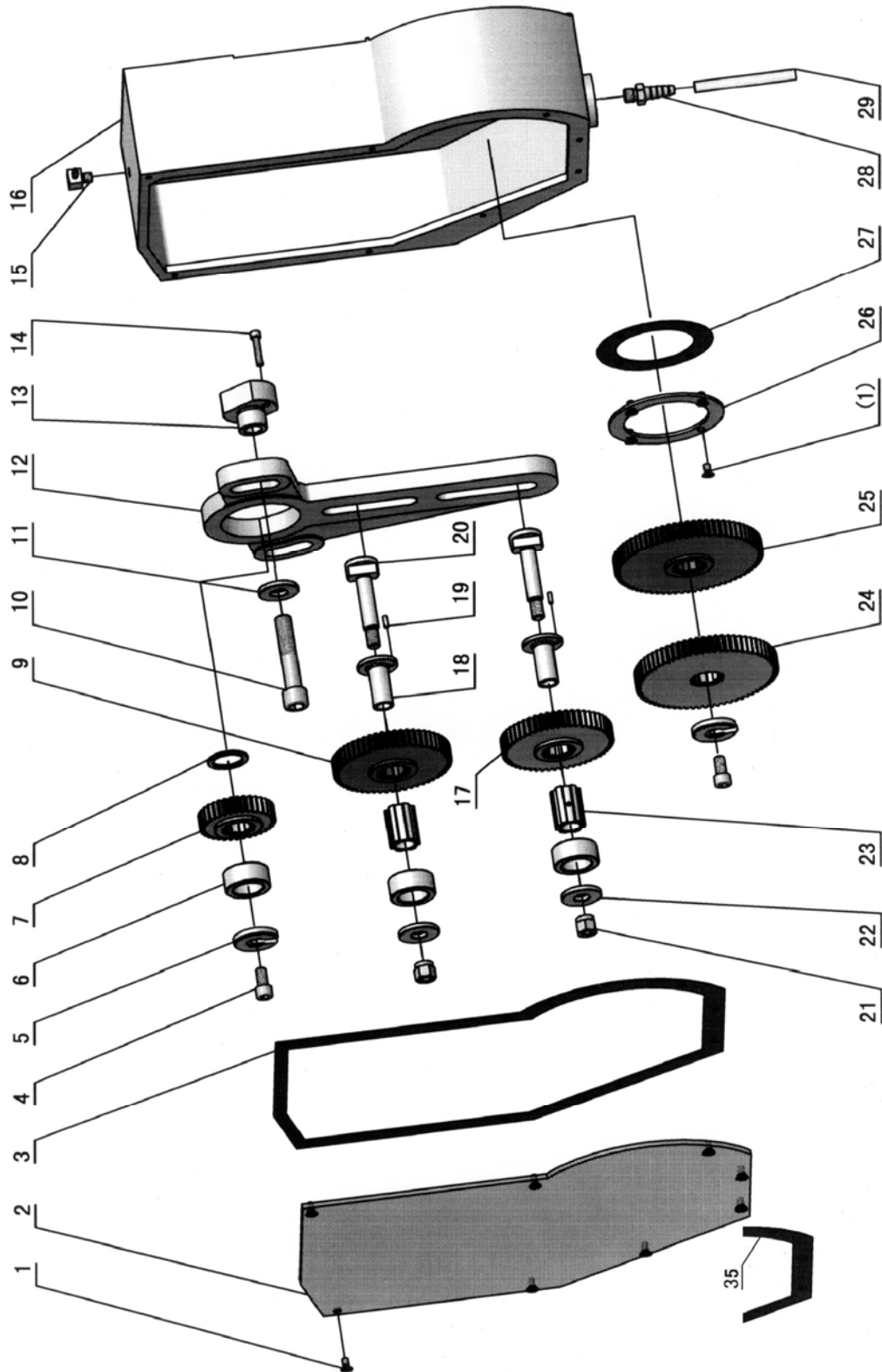

C6266A Change gear (Inch)

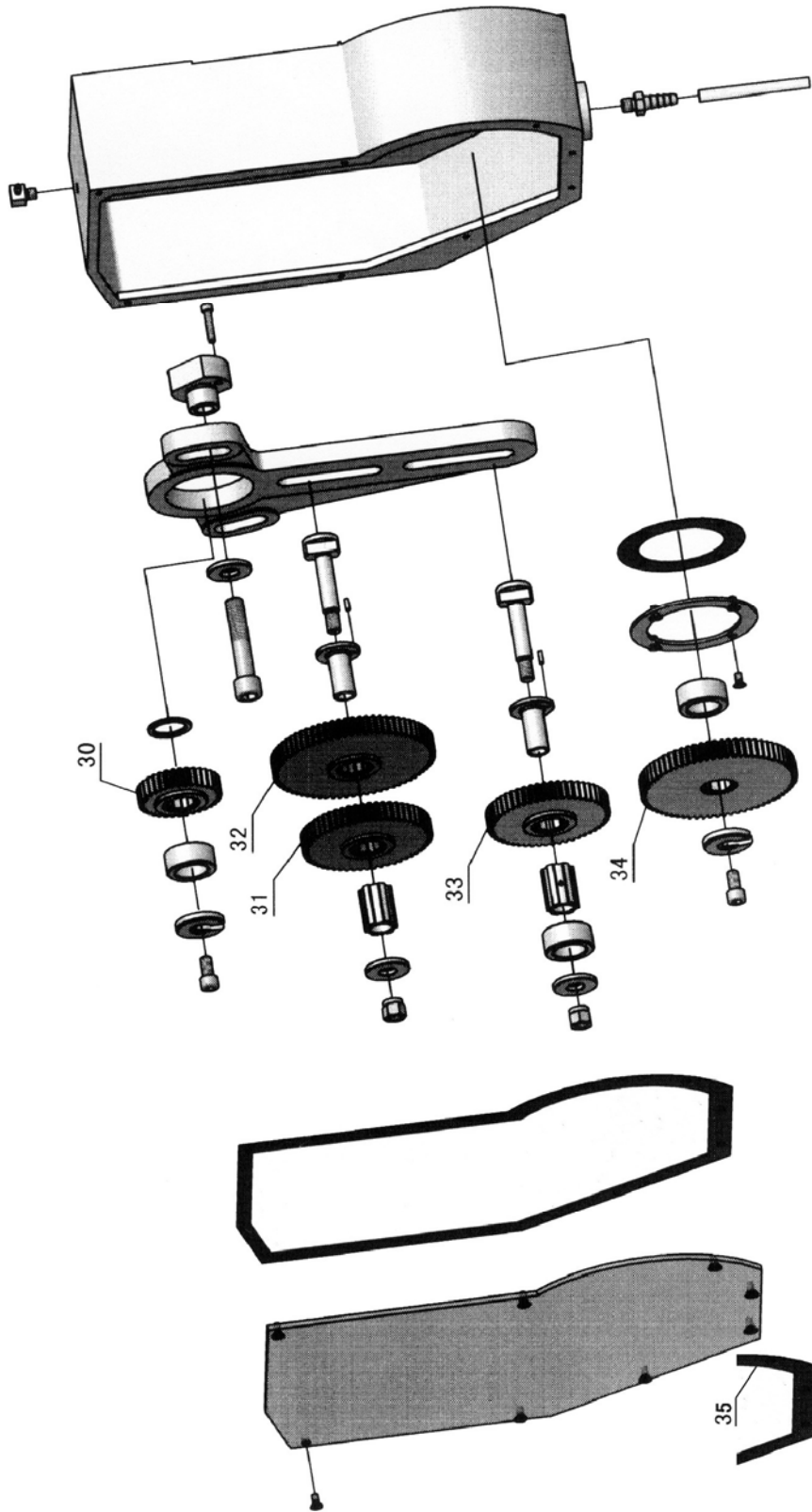

No.	Part No.	Name	Specifications	Qty.
1	GB818-85	Screw	M6×12	12
2	C6266A-20-13	Case Cover		1
3	C6266A-20-14	Gasket		1
4	GB70-85	Screw	M10×20	2
5	C6266A-20-12	Open Washer		2
6	C6266A-20-08	Washer		3
7	C6266A-20-03	Change Gear	Z=36	1
8	C6266A-20-22	Washer		1
9	C6266A-20-04	Change Gear	Z=57	1
10	GB70-85	Screw	M16×80	2
11	C6266A-20-21	Washer		2
12	C6266A-20-02	Change Gear Bracket		1
13	C6266A-20-20	Fixed Sleeve		2
14	GB70-85	Screw	M6×30	2
15	C6266A-20-18	Oil Intake Connector		1
16	C6266A-20-01	Change Gear Box Body		1
17	C6266A-20-10	Change Gear	Z=54	1
18	C6266A-20-09	Sleeve Carrier		2
19	GB119-86	Ordinary Cylindrical Pin	4×12	2
20	C6266A-20-06	Shaft		2
21	GB6182A-86	Locking Nut With Insert	M12	2
22	C6266A-20-05	Washer		2
23	C6266A-20-07	Spline Housing		2
24	C6266A-20-11	Change Gear	Z=69	1
25	C6266A-20-15	Change Gear	Z=72	1
26	C6266A-20-17	Pressing Ring		1
27	C6266A-20-16	Gasket		1
28	C6266A-20-19	Oil Scavenge Connector		1
29		Tube	φ 10.5×δ1×1100	1
30	C6266A-20-25Y	Change Gear	Z=39	1
31	C6266A-20-27Y	Change Gear	Z=58	1
32	C6266A-20-26Y	Change Gear	Z=76	1
33	C6266A-20-04	Change Gear	Z=57	1
34	C6266A-20-28Y	Change Gear	Z=63	1
35	C6266A-20-32	Seesaw		1

CQ6280 Change gear (Metric)

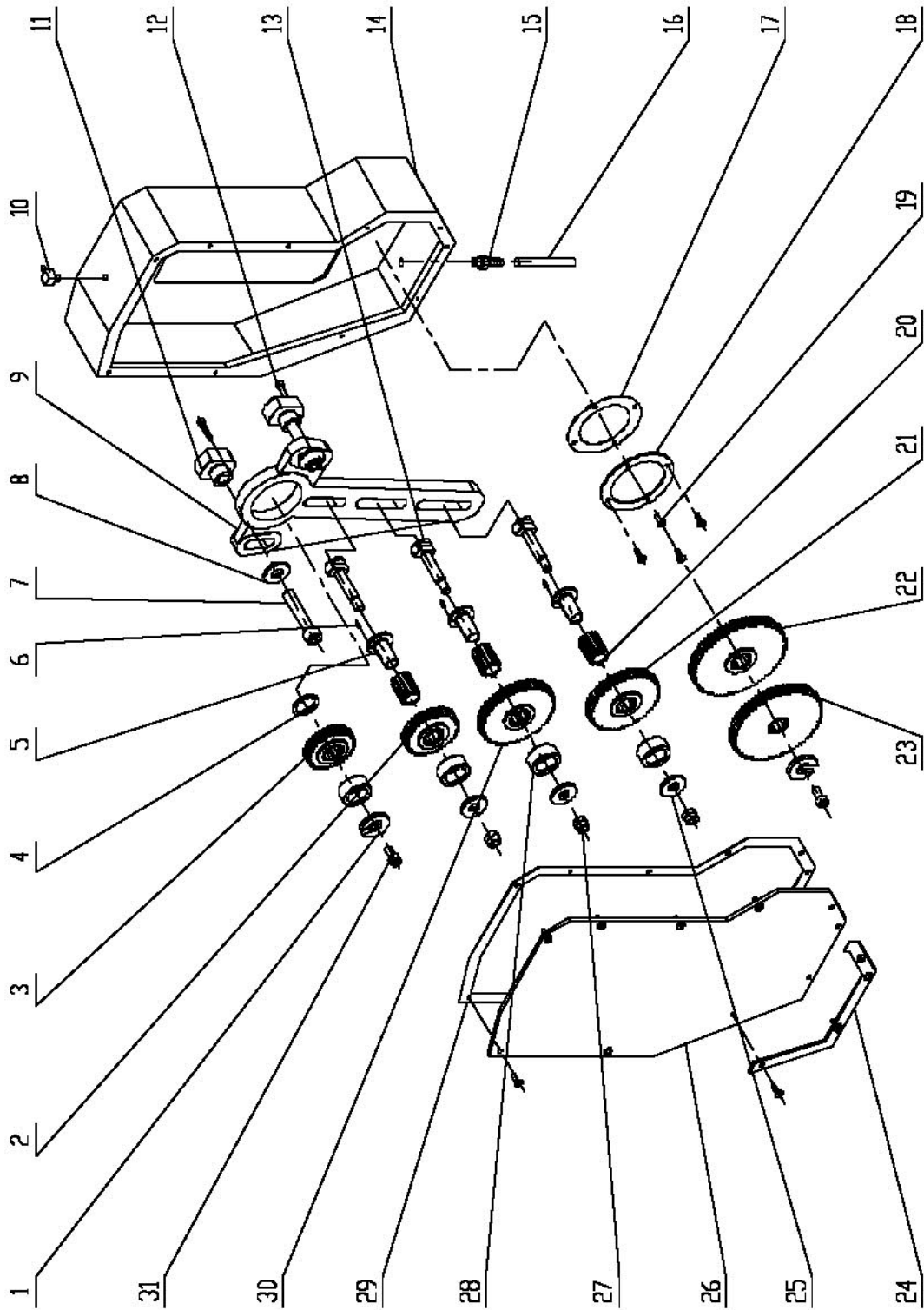

CQ6280 Change gear (Inch)

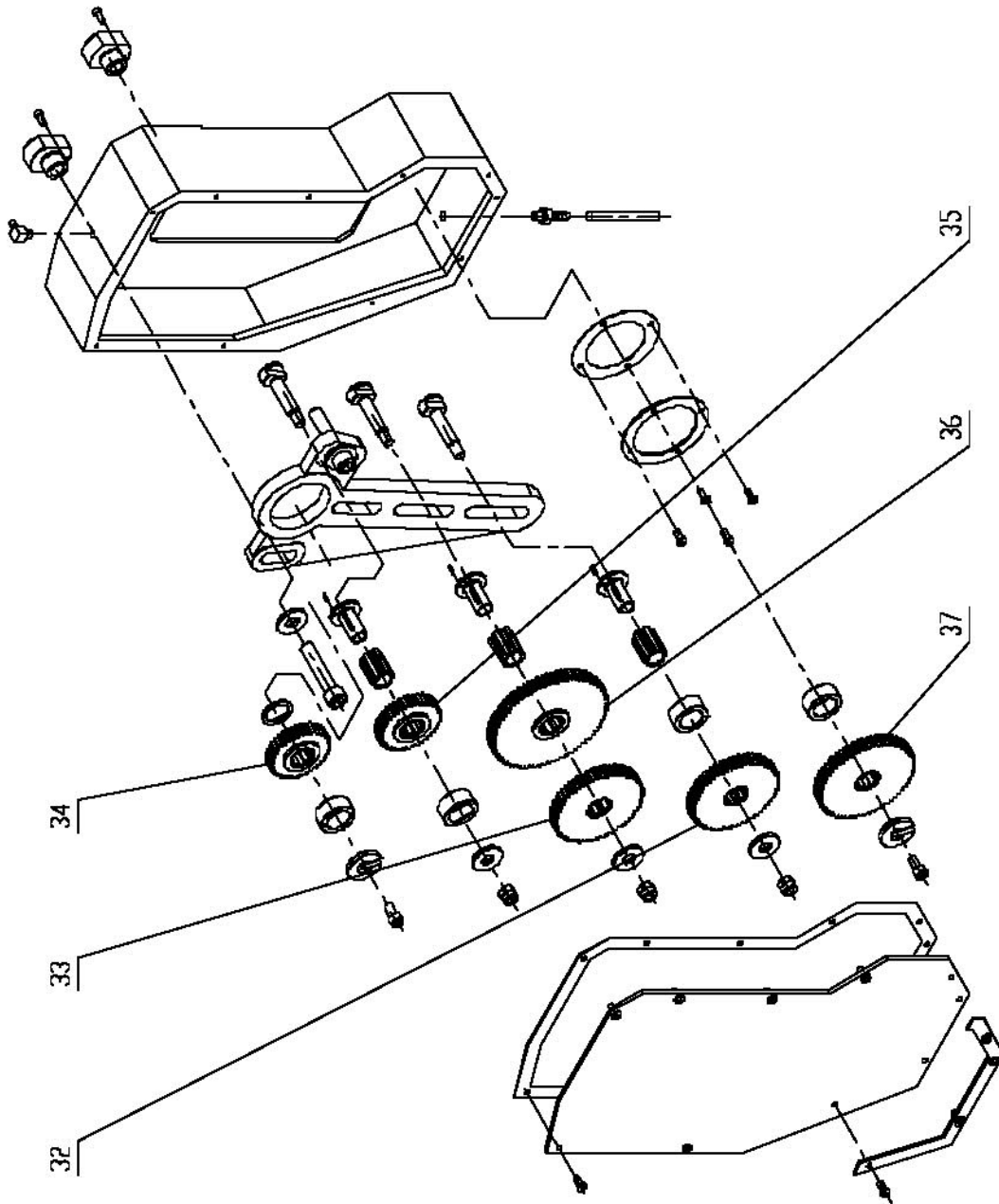

No.	Part No.	Name	Specifications	Qty.
1	C6266A-20-12	Open Washer		2
2	CQ6280-20-06	Change Gear	Z=40	1
3	C6266A-20-03	Change Gear	Z=36	1
4	C6266A-20-22	Washer		1
5	C6266A-20-09	Sleeve Carrier		3
6	GB119-86	Ordinary Cylindrical Pin	4×12	3
7	GB70-85	Screw	M16×80	2
8	C6266A-20-21	Washer		2
9	CQ6280-20-02	Change Gear Bracket		1
10	C6266A-20-18	Oil Intake Connector		1
11	C6266A-20-20	Fixed Sleeve		2
12	GB70-85	Screw	M6×30	2
13	C6266A-20-06	Shaft		3
14	CQ6280-20-01	Change Gear Box Body		1
15	C6266A-20-19	Oil Scavenge Connector		1
16		Tube	φ 10.5×δ1×1100	1
17	C6266A-20-16	Gasket		1
18	C6266A-20-17	Pressing Ring		1
19	GB818-85	Screw	M6×12	12
20	C6266A-20-07	Spline Housing		3
21	C6266A-20-10	Change Gear	Z=54	1
22	C6266A-20-15	Change Gear	Z=72	1
23	C6266A-20-11	Change Gear	Z=69	1
24	CQ6280-20-03	Platen		1
25	C6266A-20-05	Washer		2
26	CQ6280-20-04	Case Cover		1
27	GB6182A-86	Locking Nut With Insert	M12	3
28	C6266A-20-08	Washer		4
29	CQ6280-20-05	Gasket		1
30	C6266A-20-04	Change Gear	Z=57	1
31	GB70-85	Screw	M10×20	2
32	C6266A-20-04	Change Gear	Z=57	1
33	C6266A-20-27Y	Change Gear	Z=58	1
34	C6266A-20-25Y	Change Gear	Z=39	1
35	CQ6280-20-06	Change Gear	Z=40	1
36	C6266A-20-26Y	Change Gear	Z=76	1
37	C6266A-20-28Y	Change Gear	Z=63	1

Steady Rest

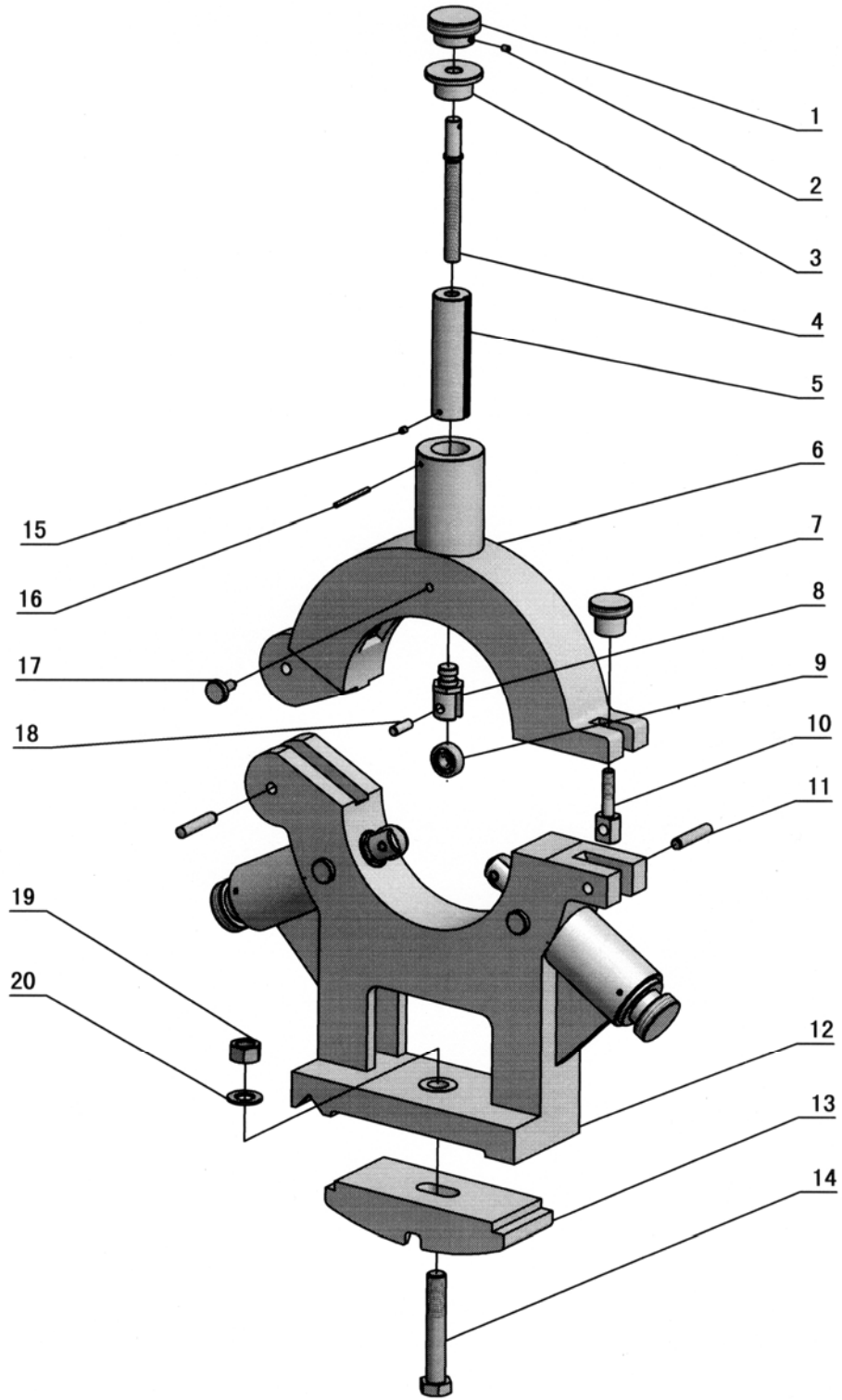

No.	Part No.	Name	Specifications	Qty.
1	C6266-10A-04	Hand Grip		3
2	GB/T78	Screw	M6×8	3
3	C6266-10A-05	Sheath		3
4	C6266-10A-03	Screw Bolt		3
5	C6266-10A-02	Quill		3
6	C6266-10A-01	Upper Body		1
7	C6251A-10-09	Hand Grip	Shared part	1
8	C6251A-10-02	Pressure Head	Shared part	3
9	GB/T276	Bearing 6300-2RS	10×35×11	3
10	C6251A-10-10	Screw Bolt	Shared part	1
11	GB/T119.2	Cylindrical Pin	12×60	2
12	C6266-10A-06	Lower Body		1
12	CQ6280-10A-06	Lower Body		1
13	C6266-08-17	Brake Block	Shared part	1
14	GB/T37	Screw Bolt	M20×120	1
15	GB/T77	Screw	M6×8	3
16	GB/T879	Resilient Cylindrical Pin	5×60	3
17	RUN6246-110018	Screw	Shared part	3
18	C6251A-10-03	Pin	Shared part	3
19	GB/T56	Hexagonal Thick Nut	M20	1
20	GB/T97.2	Washer	20	1

Follow Rest

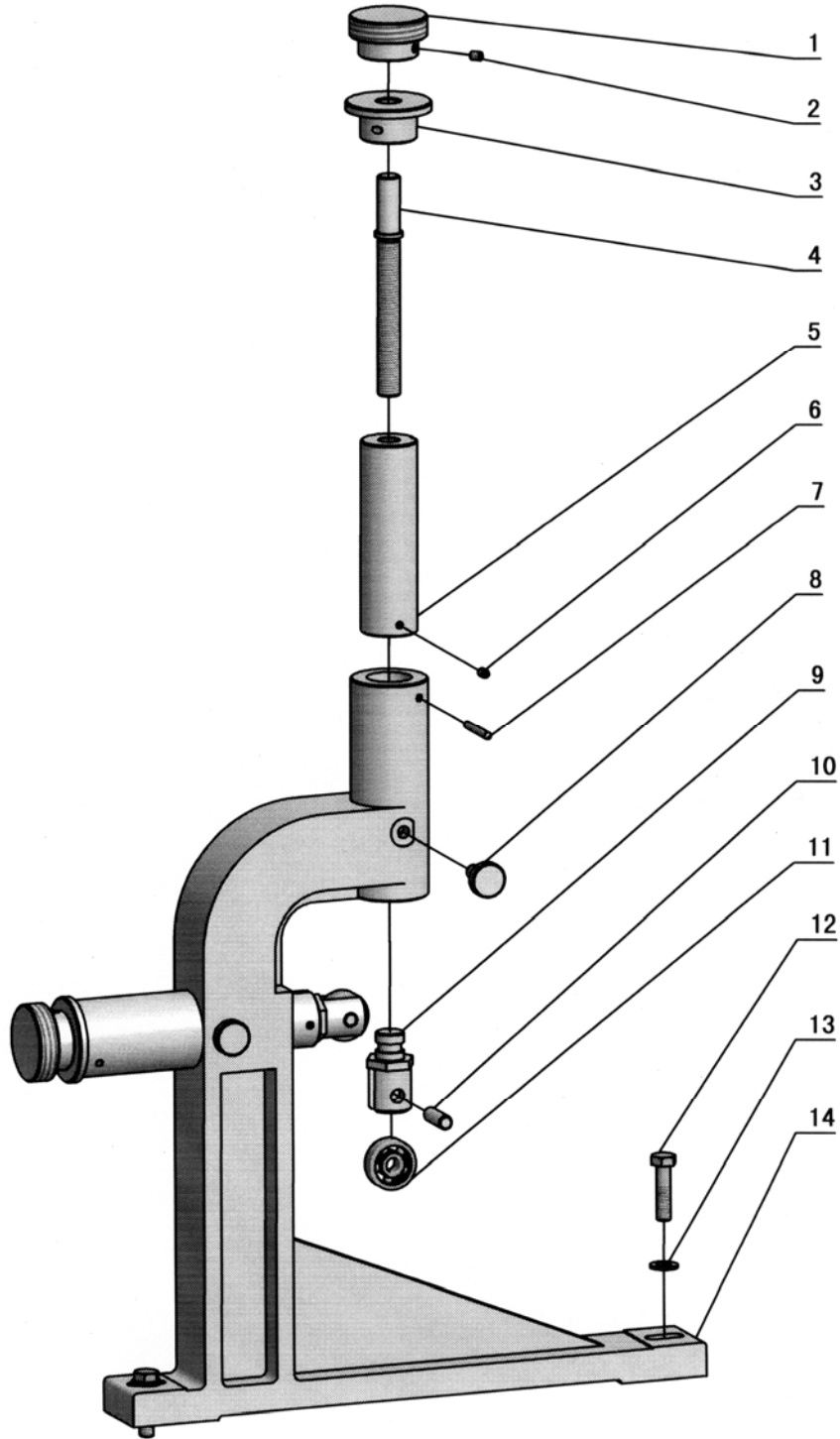

No.	Part No.	Name	Specifications	Qty.
1	C6266-10A-04	Hand Grip	Shared part	2
2	GB/T78-1985	Screw	M6×8	2
3	C6266-10B-04	Sheath		2
4	C6266-10B-03	Screw Bolt		2
5	C6266-10B-02	Sheath		2
6	GB/T77-1985	Screw	M6×8	2
7	GB/T879-1986	Resilient Cylindrical Pin	5×40	2
8	RUN6246-110018	Screw	Shared part	2
9	C6266-10B-05	Pressure Head		2
10	GB119-86 (Type A)	Cylindrical Pin	φ 10×20	2
11	GB/T276-1994	Ball Bearing 6200-2RS	10×30×9	2
12	GB/T5782-1986	Hexagonal Head Bolt	M10×40	2
13	GB/T97.1-1985	Flat Washer	10	2
14	C6266-10B-01	Movable Support Body		1
14	CQ6280-10B-01	Movable Support Body		1

Copying Device

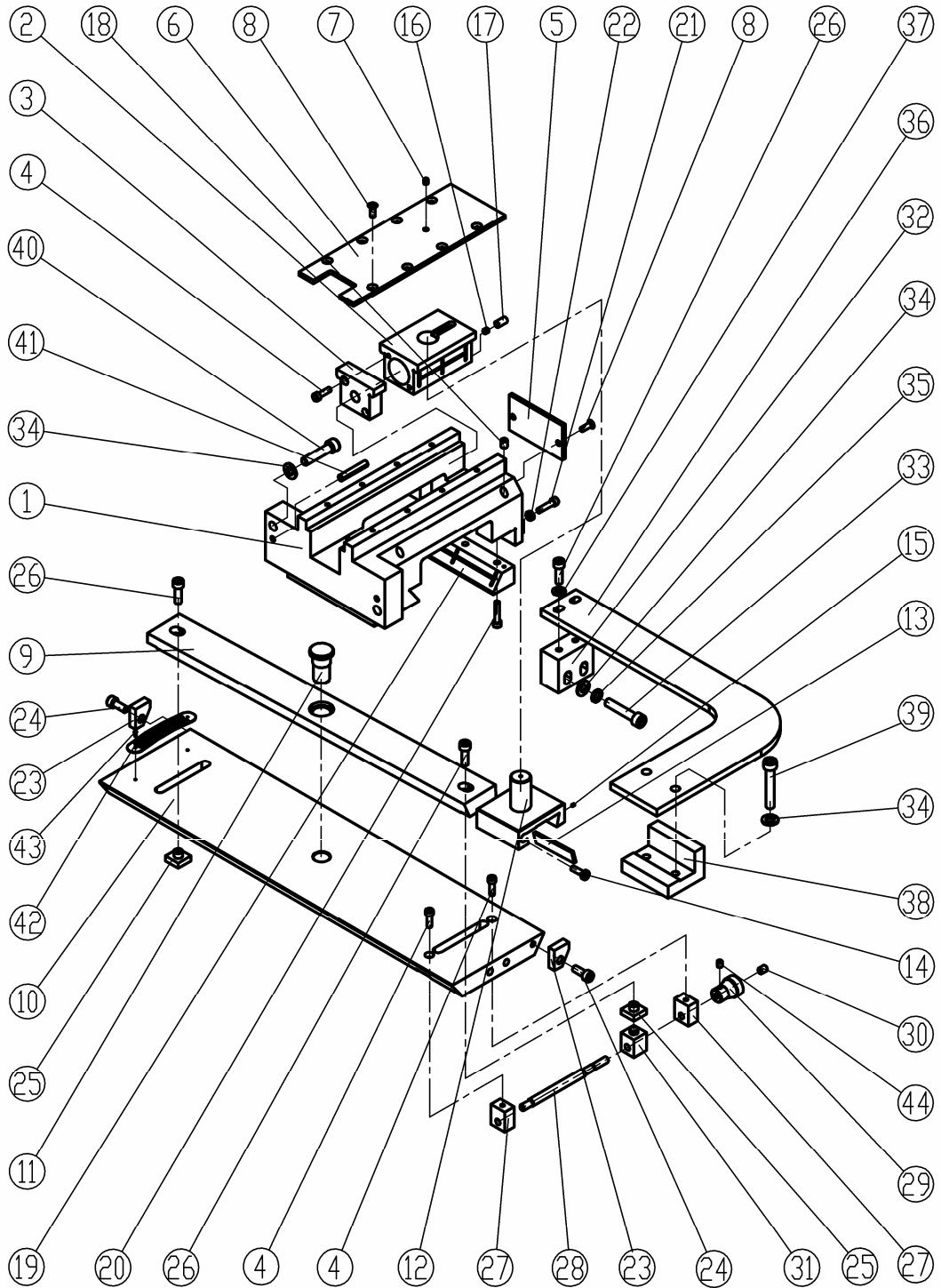

No.	Part No.	Name	Specification	Qty
1	C6266A-17-03	Main Support		1
2	C6241-115014	Slide Block		1
3	C6266A-17-01	End Block		1
4	GB70-85	Socket Head Cap Screw	M6 × 20	4
5	C6241-115002	Stopper		1
6	C6241-115013	Press Plate Cover		1
6	CQ6280-17-01	Press Plate Cover		1
7	GB1155-89	Press-Fit Oil Cup	6	1
8	GB819-85	Cross Recess Sunk Screw	M6 × 16	10
9	C6241-115012	Profiling Plate		1
10	C6241-115034	Profiling Seat		1
11	C6241-115016	Position Axle		1
12	C6241-115015	Pivot		1
13	C6241-115028	Inlaid Strip		1
14	C6241-115029	Press Screw		2
15	C6241-115026	Block Pin		3
16	C6241-115027	Copper Washer		1
17	GB77-85	Socket Flat Set Screw	M8 × 16	1
18	GB1155-89	Press-Fit Oil Cup	8	2
19	C6266A-17-04	Wedge		1
20	GB70-85	Socket Head Cap Screw	M6 × 30	4
21	GB70-85	Socket Head Cap Screw	M6 × 25	4
22	GB6170-86	Nut	M6	4
23	C6241-115003	Stopper		2
24	GB70-85	Socket Head Cap Screw	M8 × 20	2
25	C6241-115018	Mobile Block		2
26	GB70-85	Socket Head Cap Screw	M8 × 25	4
27	C6241-115025	Adjustment Supporter		2
28	C6241-115019	Adjustment Screw		1
29	C6241-115030	Handle		1
30	GB77-85	Socket Flat Set Screw	M8 × 10	1
31	C6241-115020	Adjustment Nut		1
32	C6266A-17-02	Connection Block		1
33	GB70-85	Socket Head Cap Screw	M10 × 50	2
34	GB97.1-85	Flat Washer	10	8
35	GB93-87	Spring Washer	10	2
36	C6241-115032	Pull Rod		1
37	GB97.1-85	Flat Washer	8	2
38	C6241-115033	Pressed Block		1
39	GB70-85	Socket Head Cap Screw	M10 × 60	2

No.	Part No.	Name	Specification	Qty
40	GB70-85	Socket Head Cap Screw	M10 × 45	2
41	GB879-86	Spring Cylindrical Pin	8 × 45	2
42	C6241-115009	Sign Board		1
43	GB827-86	Rivet	2 × 5	4
44	GB78-85	Screw	M5 × 6	1

Chuck Guard

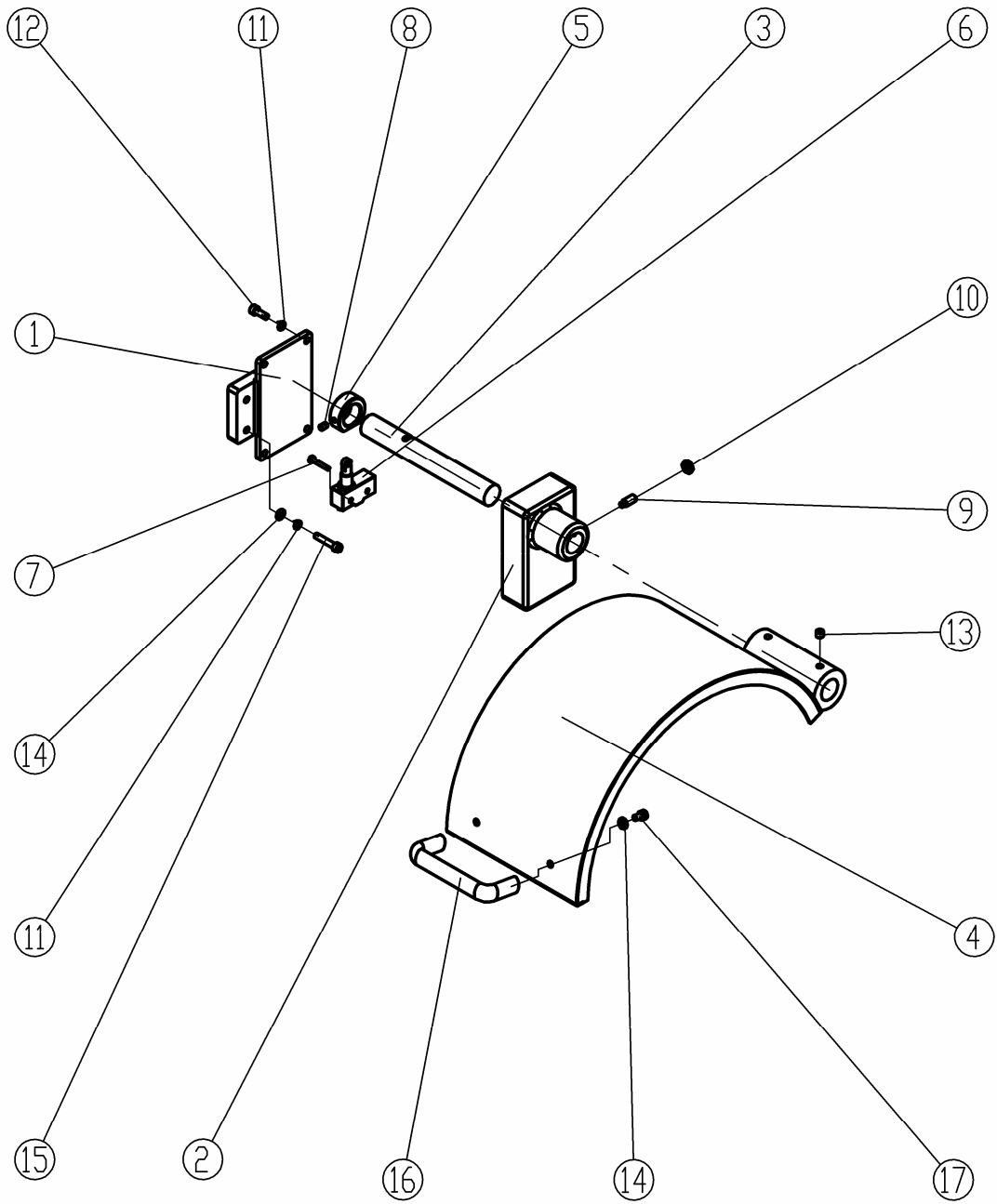

No.	Part No.	Name	Specification	Qty
1	RUN6246-F101002F	Support		1
2	C6266A-16-02	Guard Stand		1
3	C6251A-16A-02	Shaft		1
4	C6266A-16-01	Cover		1
5	C0632-F06-05	Sleeve		1
6		Microswitch		1
7	GB818-85	Screw	M4 × 25	2
8	GB78-85	Screw	M6 × 10	1
9	GB79-85	Screw	M8 × 20	1
10	GB6172-86	Nut	M8	1
11	GB93-87	Spring Washer	6	6
12	GB70-85	Socket Head Cap Screw	M6 × 16	4
13	GB80-85	Screw	M8 × 8	3
14	GB97.1-85	Flat Washer	6	4
15	GB70-85	Socket Head Cap Screw	M6 × 30	2
16	HY8315.4	Handle	A114	1
17	GB70-85	Socket Head Cap Screw	M6 × 10	2

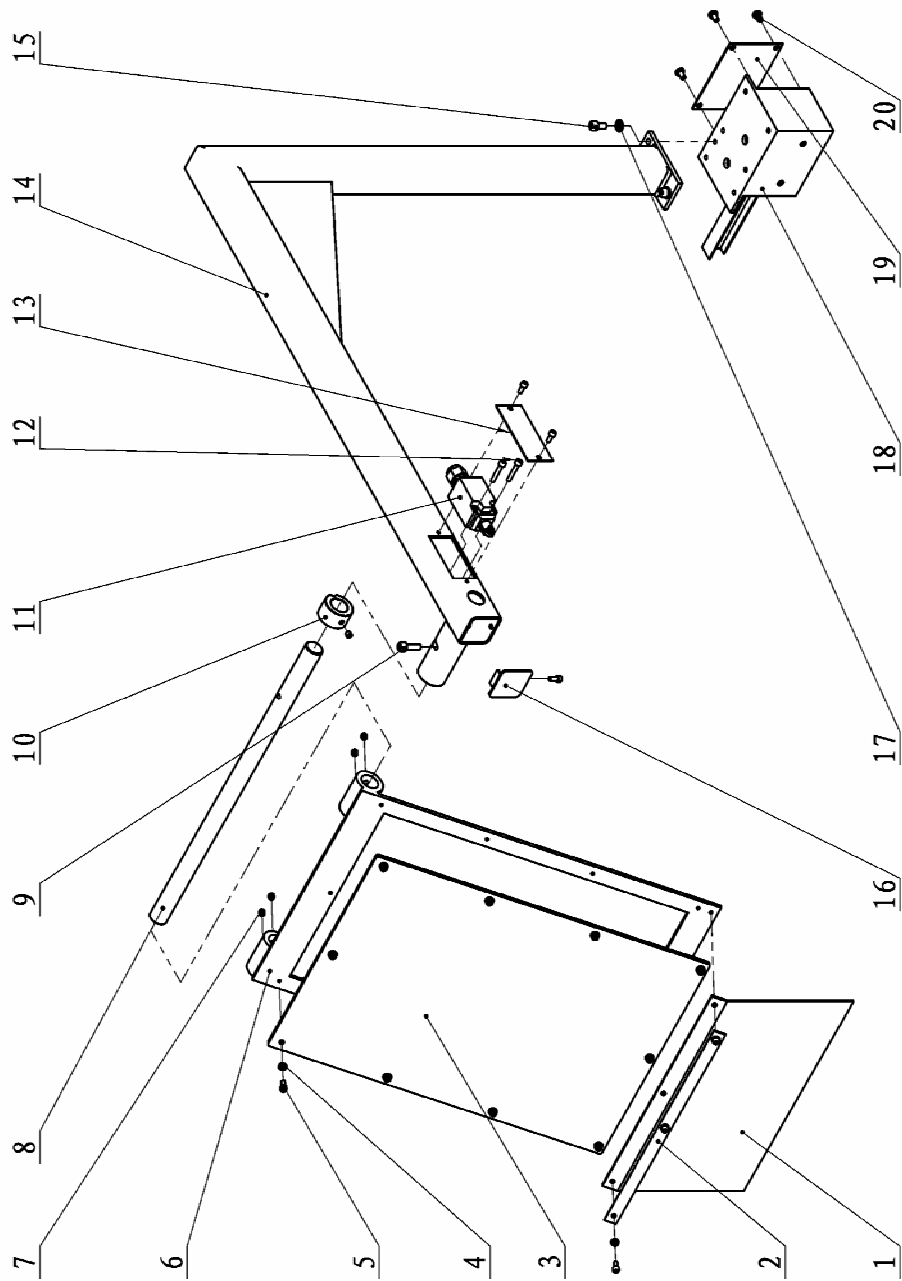

No.	Part No.	Name	Specification	Qty
1	C6266A-19-19-03	Chip Cover		1
2	C6251A-19-21-09	Clamp		1
3	C6266A-19-19-05	Chip Cover		1
4	GB97.1-85	Washer	4	13
5	GB70-85	Screw	M4×10	16
6	C6266A-19-19-04	Chip Cover Fixing Plate		1
7	GB80-85	Screw	M6×6	5
8	C6266A-19-19-02	Shaft		1
9	GB70-85	Screw	M6×20	1
10	C6251A-19-21-04	Lock for Switch Stop		1
11	QKS7	Switch	QKS7	1
12	GB70-85	Screw	M4×25	2
13	C6251A-19-21-02	Chip Cover Plate		1
14	C6266A-19-19-01	Main Block		1
15	GB70-85	Screw	M6×12	3
16	C6251A-19-21-03	Chip Cover Plate		1
17	GB97.1-85	Washer	6	3
18	C6266A-19-19-06	cable box		1
19	C6266A-19-19-07	cover plate		1
20	GB818-85	Screw	M5×8	4