



OPERATOR'S MANUAL



HYDRAULIC BOX AND PAN BRAKE MODEL: BB-12014H

Baileigh Industrial, Inc.
P.O. Box 531
Manitowoc, WI 54221-0531
Phone: 920.684.4990
Fax: 920.684.3944
sales@baileighindustrial.com

REPRODUCTION OF THIS MANUAL IN ANY FORM WITHOUT WRITTEN APPROVAL OF BAILEIGH INDUSTRIAL, INC. IS PROHIBITED. Baileigh Industrial, Inc. does not assume and hereby disclaims any liability for any damage or loss caused by an omission or error in this Operator's Manual, resulting from accident, negligence, or other occurrence.



Table of Contents

THANK YOU & WARRANTY	1
INTRODUCTION.....	3
GENERAL NOTES.....	3
SAFETY INSTRUCTIONS	4
SAFETY PRECAUTIONS	6
TECHNICAL SPECIFICATIONS	8
TECHNICAL SUPPORT	8
UNPACKING AND CHECKING CONTENTS.....	9
Cleaning	9
TRANSPORTING AND LIFTING	10
INSTALLATION.....	11
Anchoring the Machine.....	12
DESCRIPTION.....	12
OVERALL DIMENSIONS.....	13
GETTING TO KNOW YOUR MACHINE	14
ELECTRICAL.....	17
Power cord connection:	18
CONTROL FUNCTIONS.....	20
OPERATION – MANUAL CYCLE	21
OPERATION – AUTO CYCLE	23
FINGER REMOVAL.....	25
BENDING ALLOWANCE	25
UNDERSTANDING SPRINGBACK	25
MATERIAL SELECTION.....	26
MACHINE ADJUSTMENTS	26
Clamp Alignment (end to end).....	26
Clamping Beam Pressure Adjustments.....	27
Set Back / Radius.....	27
FACTORY SETTINGS for CLAMPING BEAM.....	28
CLAMPING BEAM ROLLER SWITCH SETTING	29
Top Leaf Adjustment	30
Bending Leaf Edge Alignment.....	31
LUBRICATION AND MAINTENANCE	32
Storing Machine for Extended Period of Time	32
Hydraulic Oil	33
Oil Disposal	33
HYDRAULIC TANK.....	34
Hydraulic Parts Identification	34
HYDRAULIC SCHEMATIC	35
MANIFOLD BLOCK	36
FRAME PARTS DIAGRAM.....	37
Frame Parts List.....	38



FINGERS PARTS DIAGRAM.....	39
Fingers Parts List.....	40
SETBACK PARTS DIAGRAM.....	41
Setback Parts List.....	42
CLAMPING CYLINDER PARTS DIAGRAM.....	43
Clamping Cylinder Parts List	43
BENDING CYLINDER PARTS DIAGRAM	44
Bending Cylinder Parts List	44
BACK GAUGE PARTS DIAGRAM.....	45
Back Gauge Parts List.....	45
ELECTRICAL COMPONENTS	46
Electrical Parts Identification.....	47
TERMINAL ENDS	48
ELECTRICAL SCHEMATIC 1	49
ELECTRICAL SCHEMATIC 2.....	50
ELECTRICAL SCHEMATIC 3.....	51
TROUBLESHOOTING	52



THANK YOU & WARRANTY

Thank you for your purchase of a machine from Baileigh Industrial. We hope that you find it productive and useful to you for a long time to come.

Inspection & Acceptance. Buyer shall inspect all Goods within ten (10) days after receipt thereof. Buyer's payment shall constitute final acceptance of the Goods and shall act as a waiver of the Buyer's rights to inspect or reject the goods unless otherwise agreed. If Buyer rejects any merchandise, Buyer must first obtain a Returned Goods Authorization ("RGA") number before returning any goods to Seller. Goods returned without a RGA will be refused. Seller will not be responsible for any freight costs, damages to goods, or any other costs or liabilities pertaining to goods returned without a RGA. Seller shall have the right to substitute a conforming tender. Buyer will be responsible for all freight costs to and from Buyer and repackaging costs, if any, if Buyer refuses to accept shipment. If Goods are returned in unsalable condition, Buyer shall be responsible for full value of the Goods. Buyer may not return any special order Goods. Any Goods returned hereunder shall be subject to a restocking fee equal to 30% of the invoice price.

Specifications. Seller may, at its option, make changes in the designs, specifications or components of the Goods to improve the safety of such Goods, or if in Seller's judgment, such changes will be beneficial to their operation or use. Buyer may not make any changes in the specifications for the Goods unless Seller approves of such changes in writing, in which event Seller may impose additional charges to implement such changes.

Limited Warranty. Seller warrants to the original end-user that the Goods manufactured or provided by Seller under this Agreement shall be free of defects in material or workmanship for a period of twelve (12) months from the date of purchase, provided that the Goods are installed, used, and maintained in accordance with any instruction manual or technical guidelines provided by the Seller or supplied with the Goods, if applicable. The original end-user must give written notice to Seller of any suspected defect in the Goods prior to the expiration of the warranty period. The original end-user must also obtain a RGA from Seller prior to returning any Goods to Seller for warranty service under this paragraph. Seller will not accept any responsibility for Goods returned without a RGA. The original end-user shall be responsible for all costs and expenses associated with returning the Goods to Seller for warranty service. In the event of a defect, Seller, at its sole option, shall repair or replace the defective Goods or refund to the original end-user the purchase price for such defective Goods. Goods are not eligible for replacement or return after a period of 30 days from date of receipt. The foregoing warranty is Seller's sole obligation, and the original end-user's exclusive remedy, with regard to any defective Goods. This limited warranty does not apply to: (a) die sets, tooling, and saw blades; (b) periodic or routine maintenance and setup, (c) repair or replacement of the Goods due to normal wear and tear, (d) defects or damage to the Goods resulting from misuse, abuse, neglect, or accidents, (e) defects or damage to the Goods resulting from improper or unauthorized alterations, modifications, or changes; and (f) any Goods that has not been installed and/or maintained in accordance with the instruction manual or technical guidelines provided by Seller.

EXCLUSION OF OTHER WARRANTIES. THE FOREGOING LIMITED WARRANTY IS IN LIEU OF ALL OTHER WARRANTIES, EXPRESS OR IMPLIED. ANY AND ALL OTHER EXPRESS, STATUTORY OR IMPLIED WARRANTIES, INCLUDING BUT NOT LIMITED TO, ANY WARRANTY OF MERCHANTABILITY OR FITNESS FOR ANY PARTICULAR PURPOSE ARE EXPRESSLY DISCLAIMED. NO WARRANTY IS MADE WHICH EXTENDS BEYOND THAT WHICH IS EXPRESSLY CONTAINED HEREIN.

Limitation of Liability. IN NO EVENT SHALL SELLER BE LIABLE TO BUYER OR ANY OTHER PARTY FOR ANY INCIDENTAL, CONSEQUENTIAL OR SPECIAL DAMAGES (INCLUDING, WITHOUT LIMITATION, LOST PROFITS OR DOWN TIME) ARISING FROM OR IN MANNER CONNECTED WITH THE GOODS, ANY BREACH BY SELLER OR ITS AGENTS OF THIS AGREEMENT, OR ANY OTHER CAUSE WHATSOEVER, WHETHER BASED ON CONTRACT, TORT OR ANY OTHER THEORY OF LIABILITY. BUYER'S REMEDY WITH RESPECT TO ANY CLAIM ARISING UNDER THIS AGREEMENT IS STRICTLY LIMITED TO NO MORE THAN THE AMOUNT PAID BY THE BUYER FOR THE GOODS.



Force Majeure. Seller shall not be responsible for any delay in the delivery of, or failure to deliver, Goods due to causes beyond Seller's reasonable control including, without limitation, acts of God, acts of war or terrorism, enemy actions, hostilities, strikes, labor difficulties, embargoes, non-delivery or late delivery of materials, parts and equipment or transportation delays not caused by the fault of Seller, delays caused by civil authorities, governmental regulations or orders, fire, lightening, natural disasters or any other cause beyond Seller's reasonable control. In the event of any such delay, performance will be postponed by such length of time as may be reasonably necessary to compensate for the delay.

Installation. If Buyer purchases any Goods that require installation, Buyer shall, at its expense, make all arrangements and connections necessary to install and operate the Goods. Buyer shall install the Goods in accordance with any Seller instructions and shall indemnify Seller against any and all damages, demands, suits, causes of action, claims and expenses (including actual attorneys' fees and costs) arising directly or indirectly out of Buyer's failure to properly install the Goods.

Work By Others; Safety Devices. Unless agreed to in writing by Seller, Seller has no responsibility for labor or work performed by Buyer or others, of any nature, relating to design, manufacture, fabrication, use, installation or provision of Goods. Buyer is solely responsible for furnishing, and requiring its employees and customers to use all safety devices, guards and safe operating procedures required by law and/or as set forth in manuals and instruction sheets furnished by Seller. Buyer is responsible for consulting all operator's manuals, ANSI or comparable safety standards, OSHA regulations and other sources of safety standards and regulations applicable to the use and operation of the Goods.

Remedies. Each of the rights and remedies of Seller under this Agreement is cumulative and in addition to any other or further remedies provided under this Agreement or at law or equity.

Attorney's Fees. In the event legal action is necessary to recover monies due from Buyer or to enforce any provision of this Agreement, Buyer shall be liable to Seller for all costs and expenses associated therewith, including Seller's actual attorneys' fees and costs.

Governing Law/Venue. This Agreement shall be construed and governed under the laws of the State of Wisconsin, without application of conflict of law principles. Each party agrees that all actions or proceedings arising out of or in connection with this Agreement shall be commenced, tried, and litigated only in the state courts sitting in Manitowoc County, Wisconsin or the U.S. Federal Court for the Eastern District of Wisconsin. Each party waives any right it may have to assert the doctrine of "forum non conveniens" or to object to venue to the extent that any proceeding is brought in accordance with this section. Each party consents to and waives any objection to the exercise of personal jurisdiction over it by courts described in this section. Each party waives to the fullest extent permitted by applicable law the right to a trial by jury.

Summary of Return Policy.

- 10 Day acceptance period from date of delivery. Damage claims and order discrepancies will not be accepted after this time.
- You must obtain a Baileigh issued RGA number PRIOR to returning any materials.
- Returned materials must be received at Baileigh in new condition and in original packaging.
- Altered items are not eligible for return.
- Buyer is responsible for all shipping charges.
- A 30% re-stocking fee applies to all returns.

Baileigh Industrial makes every effort to ensure that our posted specifications, images, pricing and product availability are as correct and timely as possible. We apologize for any discrepancies that may occur. Baileigh Industrial reserves the right to make any and all changes deemed necessary in the course of business including but not limited to pricing, product specifications, quantities, and product availability.

For Customer Service & Technical Support:

Please contact one of our knowledgeable Sales and Service team members at: (920) 684-4990 or e-mail us at sales@baileighindustrial.com



INTRODUCTION

The quality and reliability of the components assembled on a Baileigh Industrial machine guarantee near perfect functioning, free from problems, even under the most demanding working conditions. However if a situation arises, refer to the manual first. If a solution cannot be found, contact the distributor where you purchased our product. Make sure you have the serial number and production year of the machine (stamped on the nameplate). For replacement parts refer to the assembly numbers on the parts list drawings.

Our technical staff will do their best to help you get your machine back in working order.

In this manual you will find: (when applicable)

- Safety procedures
- Correct installation guidelines
- Description of the functional parts of the machine
- Capacity charts
- Set-up and start-up instructions
- Machine operation
- Scheduled maintenance
- Parts lists

GENERAL NOTES

After receiving your equipment remove the protective container. Do a complete visual inspection, and if damage is noted, **photograph it for insurance claims** and contact your carrier at once, requesting inspection. Also contact Baileigh Industrial and inform them of the unexpected occurrence. Temporarily suspend installation.

Take necessary precautions while loading / unloading or moving the machine to avoid any injuries.

Your machine is designed and manufactured to work smoothly and efficiently. Following proper maintenance instructions will help ensure this. Try and use original spare parts, whenever possible, and most importantly; **DO NOT** overload the machine or make any unauthorized modifications.



Note: This symbol refers to useful information throughout the manual.



IMPORTANT **PLEASE READ THIS OPERATORS MANUAL CAREFULLY**

It contains important safety information, instructions, and necessary operating procedures. The continual observance of these procedures will help increase your production and extend the life of the equipment.

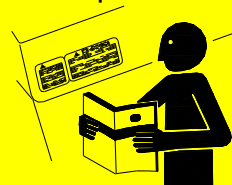

SAFETY INSTRUCTIONS

LEARN TO RECOGNIZE SAFETY INFORMATION

This is the safety alert symbol. When you see this symbol on your machine or in this manual, **BE ALERT TO THE POTENTIAL FOR PERSONAL INJURY!**

Follow recommended precautions and safe operating practices.

UNDERSTAND SIGNAL WORDS

A signal word – **DANGER**, **WARNING**, or **CAUTION** is used with the safety alert symbol. **DANGER** identifies a hazard or unsafe practice that will result in severe **Injury or Death.**

Safety signs with signal word **DANGER** or **WARNING** are typically near specific hazards.

General precautions are listed on **CAUTION** safety signs. **CAUTION** also calls attention to safety messages in this manual.



DANGER



WARNING



CAUTION



SAVE THESE INSTRUCTIONS.
Refer to them often and use them to instruct others.



PROTECT EYES

Wear safety glasses or suitable eye protection when working on or around machinery.

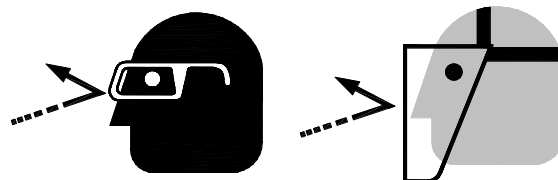

BEWARE OF CRUSH HAZARD

Closing upper beam and brake bed will result in loss of fingers or limbs if placed in machine. **NEVER** place your hand or any part of your body in this machine.

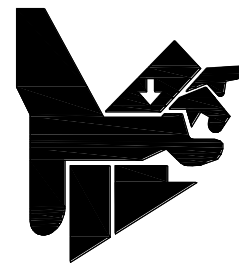

HYDRAULIC HOSE FAILURE

Exercise **CAUTION** around hydraulic hoses in case of a hose or fitting failure.



PROTECT AGAINST NOISE

Prolonged exposure to loud noise can cause impairment or loss of hearing. Wear suitable hearing protective devices such as ear muffs or earplugs to protect against objectionable or uncomfortable loud noises.

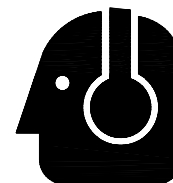

HIGH VOLTAGE

USE CAUTION IN HIGH VOLTAGE AREAS. DO NOT assume the power to be off.
FOLLOW PROPER LOCKOUT PROCEDURES.

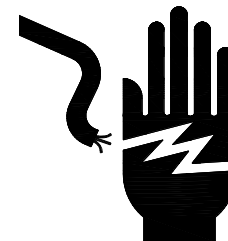



EMERGENCY STOP BUTTON

In the event of incorrect operation or dangerous conditions, the machine can be stopped immediately by pressing the **E-STOP** button. Twist the emergency stop button clockwise (cw) to reset. Note: Resetting the E-Stop will not start the machine.



SAFETY PRECAUTIONS



Metal working can be dangerous if safe and proper operating procedures are not followed. As with all machinery, there are certain hazards involved with the operation of the product. Using the machine with respect and caution will considerably lessen the possibility of personal injury. However, if normal safety precautions are overlooked or ignored, personal injury to the operator may result.

Safety equipment such as guards, hold-downs, safety glasses, dust masks and hearing protection can reduce your potential for injury. But even the best guard won't make up for poor judgment, carelessness or inattention. **Always use common sense** and exercise **caution** in the workshop. If a procedure feels dangerous, don't try it.

REMEMBER: Your personal safety is your responsibility.



WARNING: FAILURE TO FOLLOW THESE RULES MAY RESULT IN SERIOUS PERSONAL INJURY

1. **Only trained and qualified personnel can operate this machine.**
2. **Make sure guards are in place and in proper working order before operating machinery.**
3. **Remove any adjusting tools.** Before operating the machine, make sure any adjusting tools have been removed.
4. **Keep work area clean.** Cluttered areas invite injuries.
5. **Overloading machine.** By overloading the machine, you may cause injury from flying parts. **DO NOT** exceed the specified machine capacities.
6. **Machine usage. DO NOT** use the brake as a press or crushing tool.
7. **Dressing material edges.** Always chamfer and deburr all sharp edges.
8. **Do not force tool.** Your machine will do a better and safer job if used as intended. **DO NOT** use inappropriate attachments in an attempt to exceed the machines rated capacity.



9. **Use the right tool for the job. DO NOT** attempt to force a small tool or attachment to do the work of a large industrial tool. **DO NOT** use a tool for a purpose for which it was not intended.
10. **Dress appropriate. DO NOT** wear loose fitting clothing or jewelry as they can be caught in moving machine parts. Protective clothing and steel toe shoes are recommended when using machinery. Wear a restrictive hair covering to contain long hair.
11. **Use eye and ear protection.** Always wear ISO approved impact safety goggles. Wear a full-face shield if you are producing metal filings.
12. **Do not overreach.** Maintain proper footing and balance at all times. **DO NOT** reach over or across a running machine.
13. **Stay alert.** Watch what you are doing and use common sense. **DO NOT** operate any tool or machine when you are tired.
14. **Check for damaged parts.** Before using any tool or machine, carefully check any part that appears damaged. Check for alignment and binding of moving parts that may affect proper machine operation.
15. **Observe work area conditions. DO NOT** use machines or power tools in damp or wet locations. Do not expose to rain. Keep work area well lighted. **DO NOT** use electrically powered tools in the presence of flammable gases or liquids.
16. **Keep children away.** Children must never be allowed in the work area. **DO NOT** let them handle machines, tools, or extension cords.
17. **Store idle equipment.** When not in use, tools must be stored in a dry location to inhibit rust. Always lock up tools and keep them out of reach of children.
18. **DO NOT operate machine if under the influence of alcohol or drugs.** Read warning labels on prescriptions. If there is any doubt, **DO NOT** operate the machine.
19. **DO NOT** touch live electrical components or parts.
20. **Turn off** power before checking, cleaning, or replacing any parts.
21. Be sure **all** equipment is properly installed and grounded according to national, state, and local codes.
22. Inspect power and control cables periodically. Replace if damaged or bare wires are exposed. **Bare wiring can kill!**
23. **DO NOT** bypass or defeat any safety interlock systems.
24. Keep visitors a safe distance from the work area.



TECHNICAL SPECIFICATIONS

Bend Length	120" (3048mm)
Bend Material Thickness	14 ga. (1.90mm) mild steel* 18 ga. (1.21mm) stainless steel**
Bend Angle	0 – 135 degrees
Beam Adjustment	1" (25.4mm)
Minimum Reverse Bend	.5" (12.7mm)
Box Depth	6" (152mm)
Finger Size	6 @ 3" (76mm) 4 @ 4" (102mm) 10 @ 5" (127mm) 6 @ 6" (152mm)
Floor Stand	2 pcs. Welded Steel
Hydraulic System Motor	3hp (2.23kw)
Power Requirements	220V, 3 Phase
Hydraulic Reservoir	18 gallons (68.13liters)
Shipping Dimensions (L x W x H)	153" x 46" x 67" (3886 x 1168 x 1702mm)
Shipping Weight	5830 lbs. (2650 kg)
Based on a material tensile strength of	*64000 PSI – mild steel **100000 PSI – stainless steel

TECHNICAL SUPPORT

Our technical support department can be reached at 920.684.4990, and asking for the support desk for purchased machines. Tech Support handles questions on machine setup, schematics, warranty issues, and individual parts needs: (other than die sets and blades).

For specific application needs or future machine purchases contact the Sales Department at: sales@baileighindustrial.com, Phone: 920.684.4990, or Fax: 920.684.3944.



Note: *The photos and illustrations used in this manual are representative only and may not depict the actual color, labeling or accessories and may be intended to illustrate technique only.*



Note: *The specifications and dimensions presented here are subject to change without prior notice due to improvements of our products.*



UNPACKING AND CHECKING CONTENTS

Your Baileigh machine is shipped complete in one crate. Separate all parts from the packing material and check each item carefully. Make certain all items are accounted for before discarding any packing material.

⚠ WARNING: SUFFOCATION HAZARD! Immediately discard any plastic bags and packing materials to eliminate choking and suffocation hazards to children and animals.

If any parts are missing, do not plug in the power cable, or turn the power switch on until the missing parts are obtained and installed correctly.

Cleaning

⚠ WARNING: DO NOT USE gasoline or other petroleum products to clean the machine. They have low flash points and can explode or cause fire.

⚠ CAUTION: When using cleaning solvents work in a well-ventilated area. Many cleaning solvents are toxic if inhaled.

Your machine may be shipped with a rustproof waxy coating and/or grease on the exposed unpainted metal surfaces. Fully and completely remove this protective coating using a degreaser or solvent cleaner. Moving items will need to be moved along their travel path to allow for cleaning the entire surface. For a more thorough cleaning, some parts will occasionally have to be removed. **DO NOT USE** acetone or brake cleaner as they may damage painted surfaces.

Follow manufacturer's label instructions when using any type of cleaning product. After cleaning, wipe unpainted metal surfaces with a light coating of quality oil or grease for protection.



Important: This waxy coating is **NOT** a lubricant and will cause the machine to stick and lose performance as the coating continues to dry





TRANSPORTING AND LIFTING

⚠ CAUTION: Lifting and carrying operations should be carried out by skilled workers, such as a truck operator, crane operator, etc. If a crane is used to lift the machine, attach the lifting chain carefully, making sure the machine is well balanced. Choose a location that will keep the machine free from vibration and dust from other machinery. Keep in mind that having a large clearance area around the machine is important for safe and efficient working conditions.

Follow these guidelines when lifting:

- Always lift and carry the machine with the lifting holes provided at the top of the machine.
- Use lift equipment such as straps, chains, capable of lifting 1.5 to 2 times the weight of the machine.
- Take proper precautions for handling and lifting.
- Check if the load is properly balanced by lifting it an inch or two.
- Lift the machine, avoiding sudden accelerations or quick changes of direction.
- Locate the machine where it is to be installed, and lower slowly until it touches the floor.
- The lift truck must be able to lift at least 1.5 – 2 times the machines gross weight.
- Make sure the machine is balanced. While transporting, avoid rough or jerky motion, and maintain a safe clearance zone around the transport area.
- Use a fork lift with sufficient lifting capacity and forks that are long enough to reach the complete width of the machine.

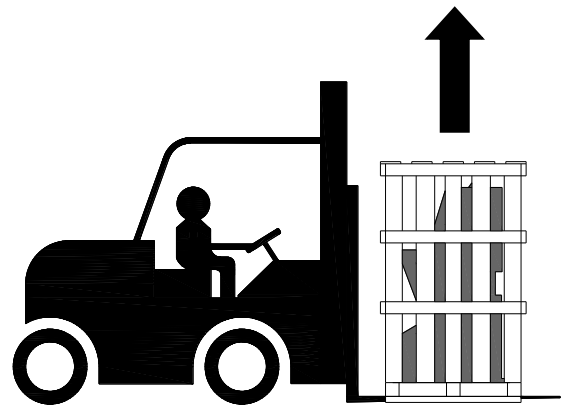
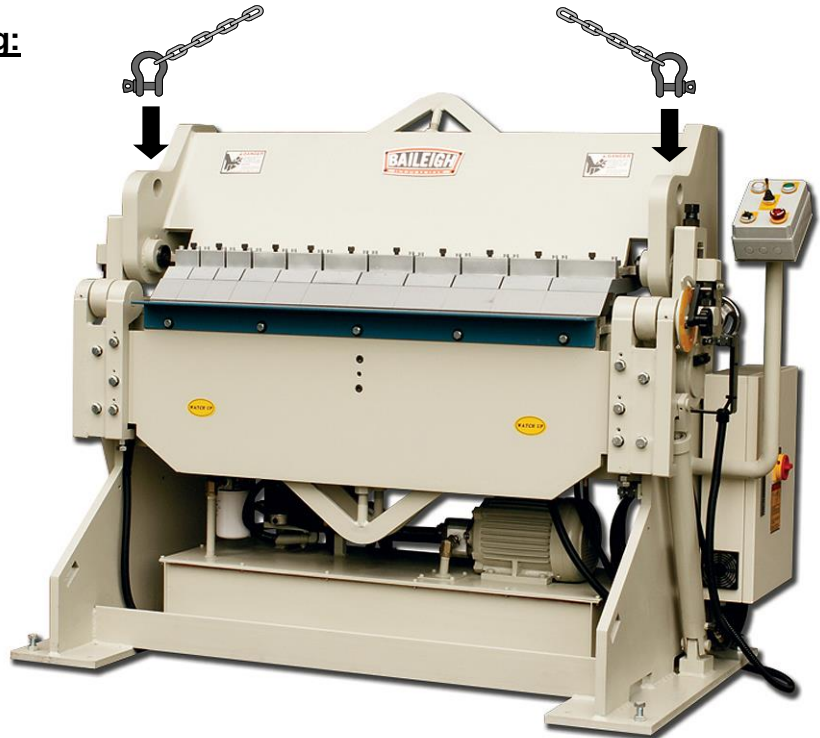



- Remove the securing bolts that attach the machine to the pallet.
- Approaching the machine from the side, lift the machine on the frame taking care that there are no cables or pipes in the area of the forks.
- Move the machine to the required position and lower gently to the floor.
- Level the machine so that all the supporting feet are taking the weight of the machine and no rocking is taking place.

INSTALLATION

IMPORTANT:

Consider the following when looking for a suitable location to place the machine:

- Overall weight of the machine.
- Weight of material being processed.
- Sizes of material to be processed through the machine.
- Space needed for auxiliary stands, work tables, or other machinery.
- Clearance from walls and other obstacles.
- Maintain an adequate working area around the machine for safety.
- Have the work area well illuminated with proper lighting.
- Keep the floor free of oil and make sure it is not slippery.
- Remove scrap and waste materials regularly, and make sure the work area is free from obstructing objects.
- If long lengths of material are to be fed into the machine, make sure that they will not extend into any aisles.
- **LEVELING:** The machine should be sited on a level, concrete floor. Provisions for securing it should be in position prior to placing the machine. The accuracy of any machine depends on the precise placement of it to the mounting surface.
- **FLOOR:** This tool distributes a large amount of weight over a small area. Make certain that the floor is capable of supporting the weight of the machine, work stock, and the operator. The floor should also be a level surface. If the unit wobbles or rocks once in place, be sure to eliminate by using shims.
- **WORKING CLEARANCES:** Take into consideration the size of the material to be processed. Make sure that you allow enough space for you to operate the machine freely.



- **POWER SUPPLY PLACEMENT:** The power supply should be located close enough to the machine so that the power cord is not in an area where it would cause a tripping hazard. Be sure to observe all electrical codes if installing new circuits and/or outlets.

Anchoring the Machine

- Once positioned, anchor the machine to the floor, as shown in the diagram, using bolts and expansion plugs or sunken tie rods that connect through holes in the base of the stand.

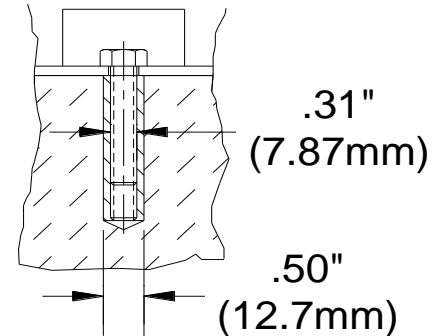

DESCRIPTION

The Baileigh Model BB-12014H Box and Pan Brake is hydraulic operated and capable of bending up to 14 ga. (1.90mm) mild steel and 18 ga. (1.21mm) stainless x 120" (3048mm) long. The machine has 26 removable fingers and a 6" (152mm) box depth allowing it to fabricate pans, boxes, channels, angles, and other shapes. Adjustable counterweights allow the operator to balance the bending leaf to correspond to material thickness. An adjustable stop gauge is included to allow the operator to perform repeat bends.



OVERALL DIMENSIONS

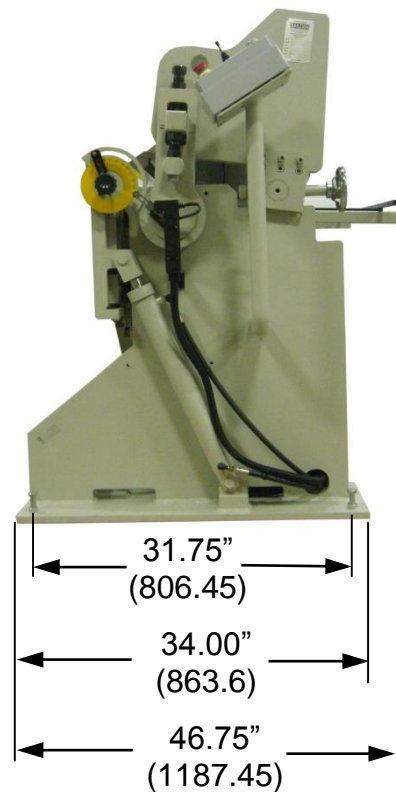
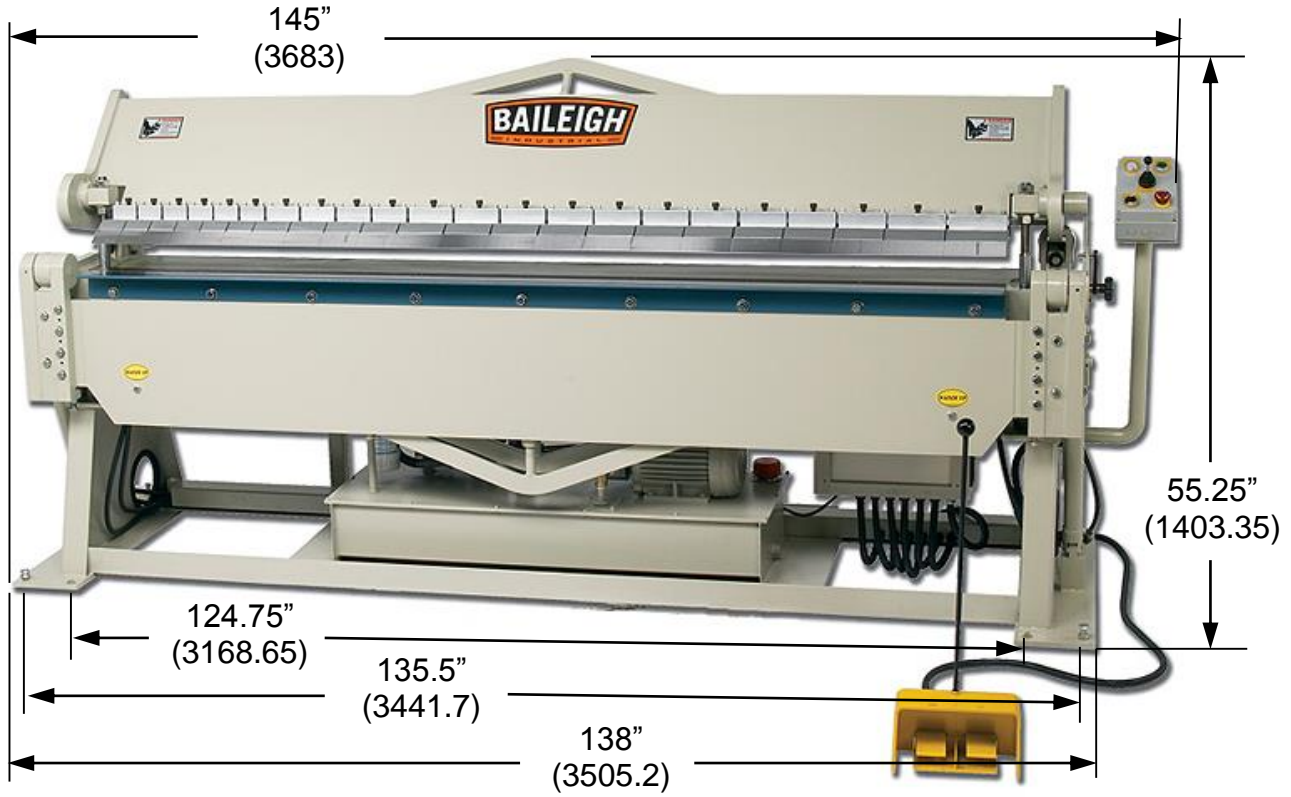



GETTING TO KNOW YOUR MACHINE

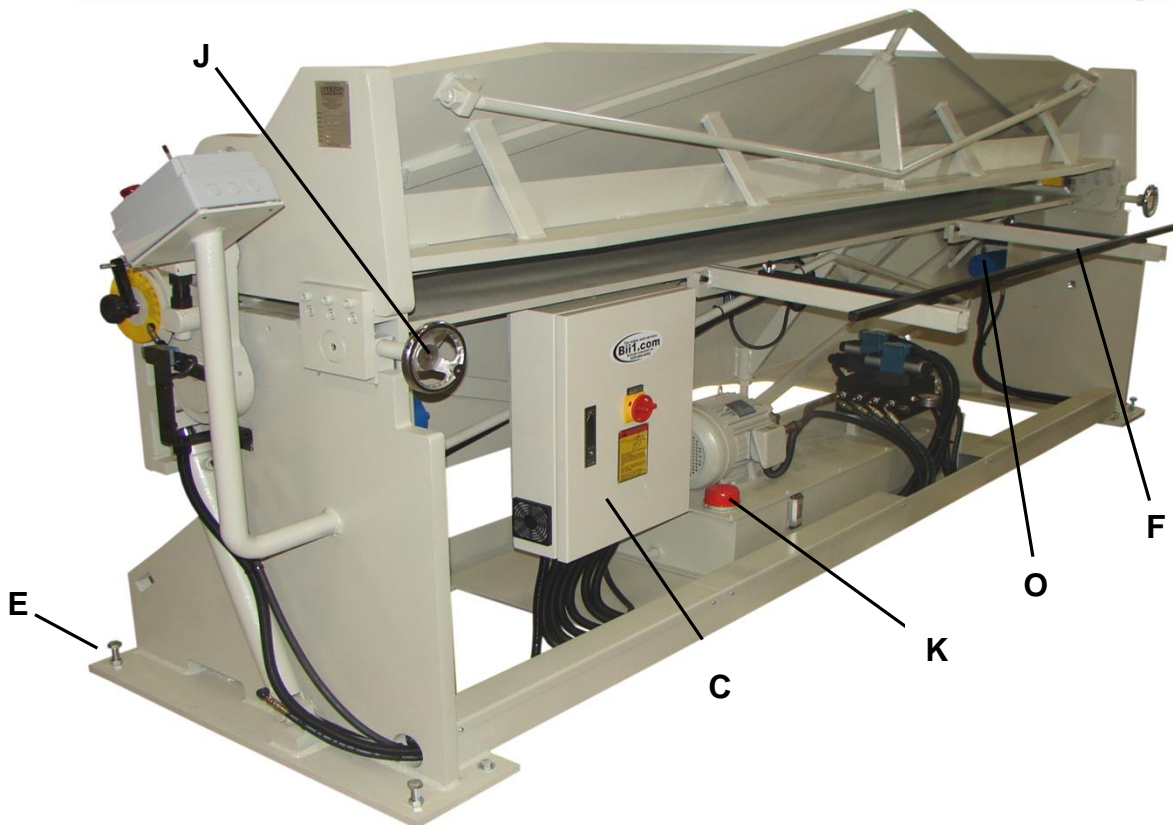
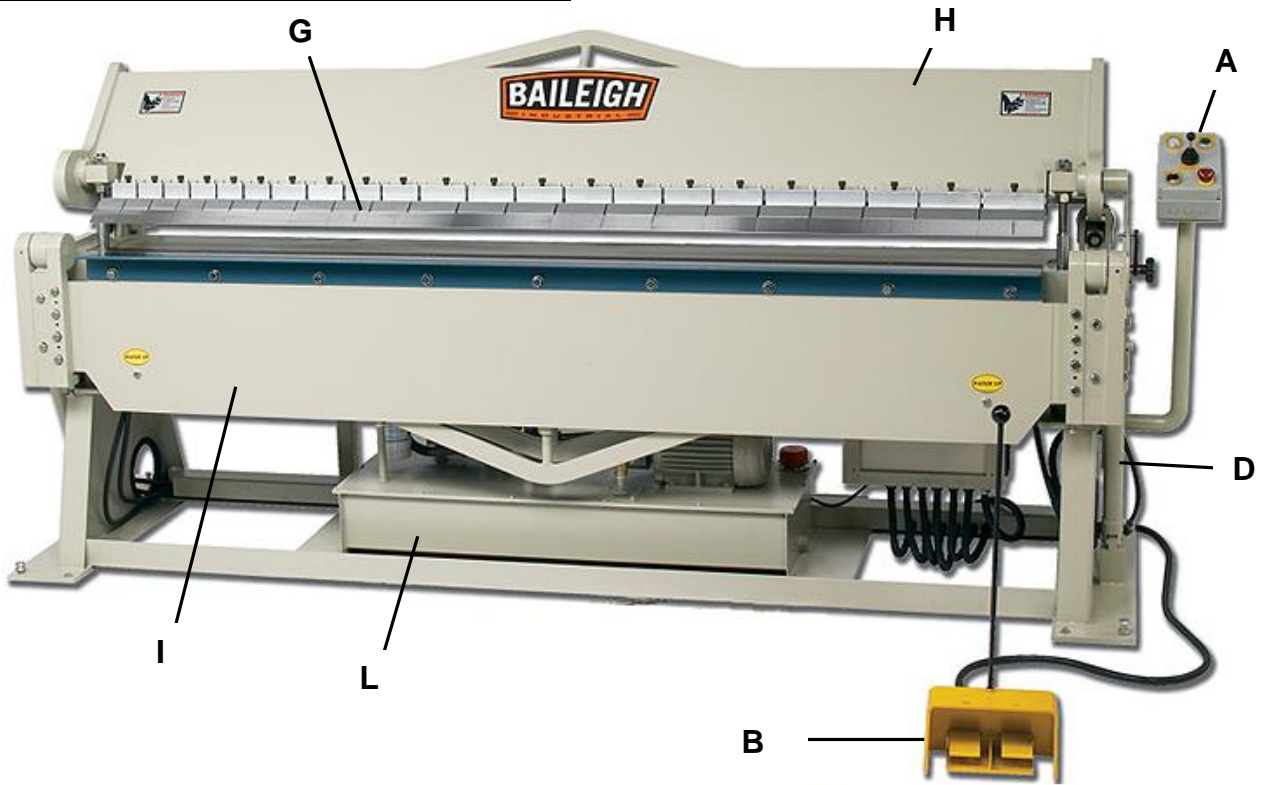

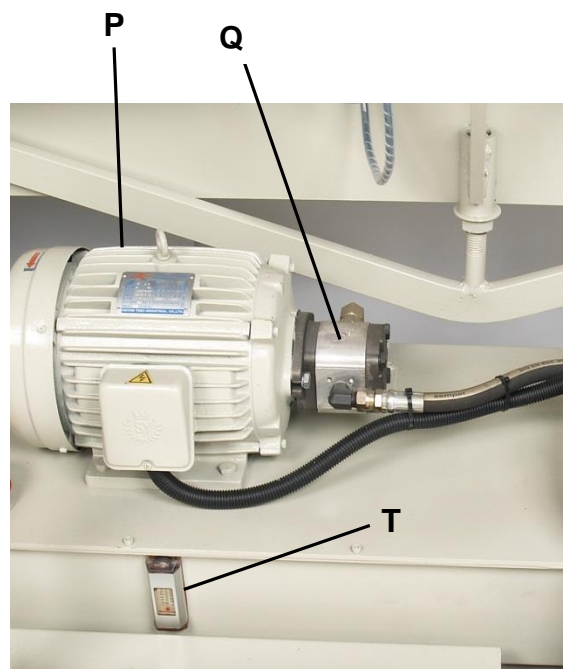
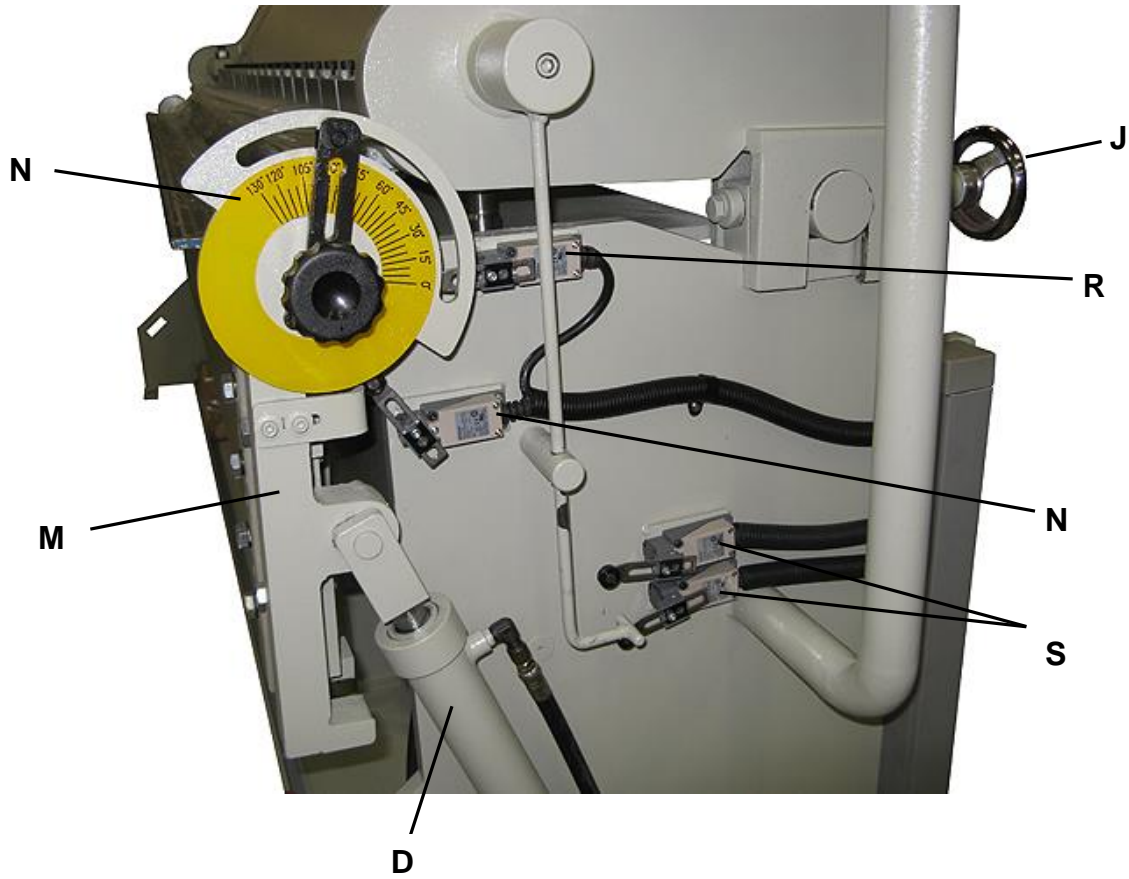



Item	Description	Function
A	Control Panel	Houses machine operator function controls
B	Footswitch Control	Operator controls Up-Down function of clamp beam
C	Electrical Enclosure	Fan cooled enclosure for electrical components
D	Hydraulic Cylinder	Two cylinders are used to move the bending leaf
E	Leveling Bolts	Used to assist in leveling the machine
F	Manual Back gauge	Operator uses as backstop for material
G	Fingers	Assorted sizes for box and pan braking
H	Clamping Beam	Holds material while bend is made
I	Bending Leaf	Adjustable from 0-135°, hydraulic cylinder driven
J	Clamp Beam Adj. Wheel	Finger setback, adjusts for material thickness
K	Hydraulic Oil Fill Cap	Remove to fill oil tank and to access filter basket
L	Hydraulic Tank	Holds 18 gallons of oil for the hydraulic system
M	Hinge	Allows the bending leaf to pivot
N	Bend Angle Indicator	Shows angle that material is to be bent at
O	Clamping Cylinders	Used to raise and lower the clamping beam
P	3 Hp. (2.23kw) Motor	Powers the hydraulic pump
Q	Hydraulic Pump	Supplies hydraulic pressure to extend the cylinders
R	Bend Angle Micro-switch	Stops the bend at the preset angle
S	Clamping Limit Switch	Stops the clamping beam at upper and lower limits
T	Oil Sight Gauge	Shows the current level of oil in the tank.



ELECTRICAL

⚠ WARNING: Baileigh Industrial is not responsible for any damage caused by wiring up to an alternative 3-phase power source other than direct 3-phase. If you are using an alternate power source, consult a certified electrician or contact Baileigh Industrial prior to energizing the machine.

⚠ CAUTION: HAVE ELECTRICAL UTILITIES CONNECTED TO MACHINE BY A CERTIFIED ELECTRICIAN!
Check if the available power supply is the same as listed on the machine nameplate.

⚠ WARNING: Make sure the grounding wire (green) is properly connected to avoid electric shock. DO NOT switch the position of the green grounding wire if any electrical plug wires are switched during hookup.

Motor Specifications

Your tool is wired for 220 volts, 60Hz alternating current. Before connecting the tool to the power source, make sure the machine is cut off from power source.

Considerations

- Observe local electrical codes when connecting the machine.
- The circuit should be protected with a time delay fuse or circuit breaker with an amperage rating slightly higher than the full load current of machine.
- A separate electrical circuit should be used for your tools. Before connecting the motor to the power line, make sure the switch is in the "OFF" position and be sure that the electric current is of the same characteristics as indicated on the tool.
- All line connections should make good contact. Running on low voltage will damage the motor.
- In the event of a malfunction or breakdown, grounding provides a path of least resistance for electric current to reduce the risk of electric shock. This tool is equipped with an electric cord having an equipment-grounding conductor and a grounding plug. The plug must be plugged into a matching outlet that is properly installed and grounded in accordance with all local codes and ordinances.



⚠ WARNING: In all cases, make certain the receptacle in question is properly grounded. If you are not sure, have a qualified electrician check the receptacle.

- Improper connection of the equipment-grounding conductor can result in risk of electric shock. The conductor with insulation having an outer surface that is green with or without yellow stripes is the equipment-grounding conductor. If repair or replacement of the electric cord or plug is necessary, do not connect the equipment-grounding conductor to a live terminal.
- Check with a qualified electrician or service personnel if the grounding instructions are not completely understood, or if in doubt as to whether the tool is properly grounded.
- Repair or replace damaged or worn cord immediately.

Power cord connection:

Open the electrical enclosure door by pushing the latch button. When the handle pops up, twist it 90°. (ccw) counter clockwise. The disconnect switch must be OFF before the door will open.

- Insert a fitting (supplied by customer) into the open hole to grip the power cord.
- Remove the (E, R, S, T) plate which covers the terminals and also remove the wire channel cover. See fig. 4.
- For three phase, connect the three power wires as shown in fig. 5 to terminals R, S & T. Connect the ground wire (typically green) to the E (Safety Ground) terminal.
- Check that the power cord has not been damaged during installation.
- Reinstall the (E, R, S, T) plate and the wire channel cover.

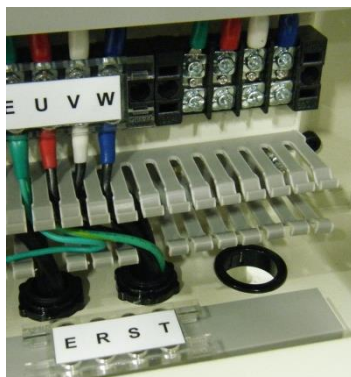

figure 4



figure 5

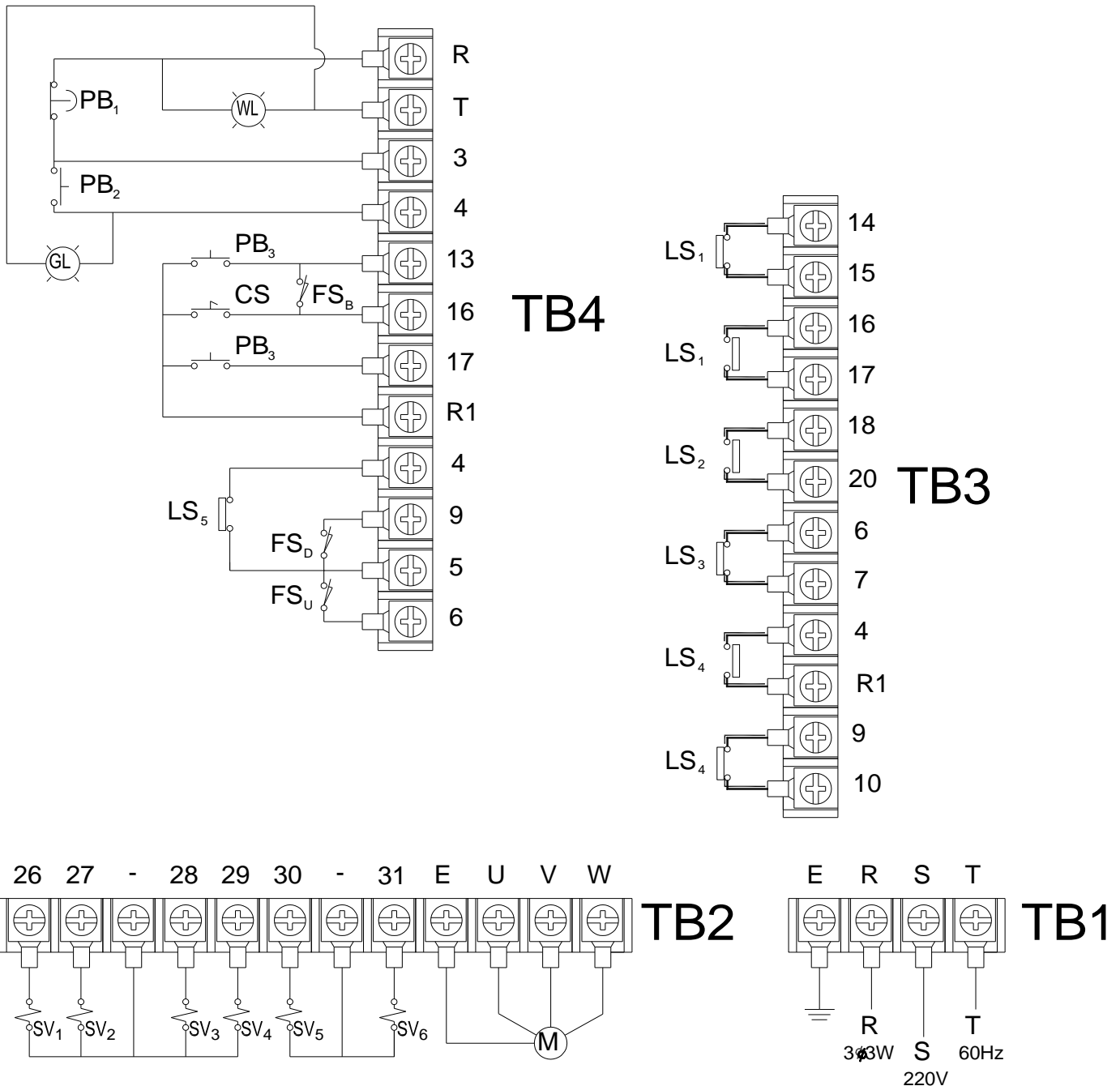

figure 6



To check the correct rotation of the motor (3 phase)

- With power connected and disconnect turned on, push the green “Start Pump” button. Press the left “DOWN” footswitch and the clamping beam “H” should come down. If not, disconnect power to the machine, and switch the R and T wires. DO NOT move the ground wire E. (Improper rotation can severely damage the hydraulic pump.)





CONTROL FUNCTIONS

POWER – Lights white when the power is supplied.

PUMP START – Push to energize the hydraulic system.

BEND INCH – Select for jogging motion of the bending leaf.

BEND AUTO – Select when a bending cycle is desired.

BEND – Pushing the joystick to the bend position raises the bending leaf to the preset angle. (Jogs in inch mode, cycles in auto mode)

RELEASE – Pushing the joystick to the release position lowers the bending leaf. (Jogs in inch mode)



Note: The bending leaf “I” will not come up until the clamping beam “H” is completely down.

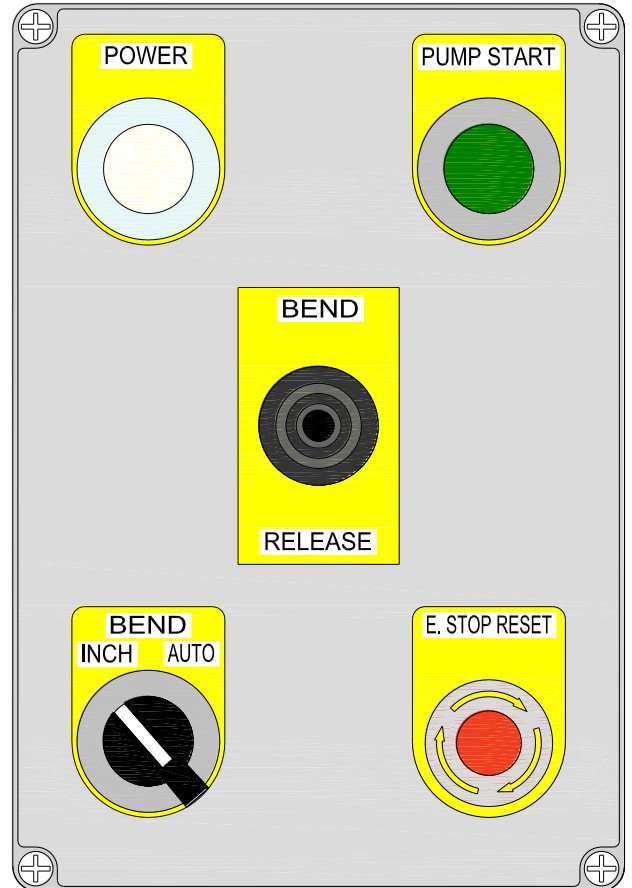

figure 7

Footswitch Functions

(Hydraulic pump must be running)

DOWN – Pressing the down pedal will bring the clamping beam down. **⚠ CAUTION: Keep hands and fingers clear.**

UP – Pressing the up pedal will raise the clamping beam.

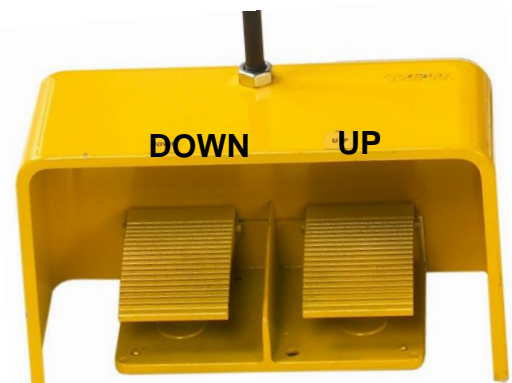

figure 8



OPERATION – MANUAL CYCLE

⚠ CAUTION: Always wear proper eye protection with side shields, safety footwear, and leather gloves to protect from burrs and sharp edges. When handling large heavy material make sure they are properly supported.

⚠ CAUTION: Keep hands and fingers clear of the clamping beam. Stand off to the side of the machine to avoid getting hit with the bending apron as it comes up to bend.

1. Set the clamping beam to the thickness of the material you will be bending. (fig. 9) shows the adjusting bolts set for 14 ga. as read on the gauge. See the section on clamping beam pressure adjustments for setting the bolts.
2. Adjust the finger setback or “W” dimension (fig. 10) with the formula: $W = (\text{material thickness}) \times 1.2$. This will help keep the material from tearing when the bend is made. To make the adjustment, loosen the setscrews on both ends of the machine as indicated with the arrow in (fig. 11). Turn the handwheels to set the “W” dimension along the full length of the clamping beam.
3. If you are doing box and pan braking, arrange the fingers accordingly. (See the section on finger removal).

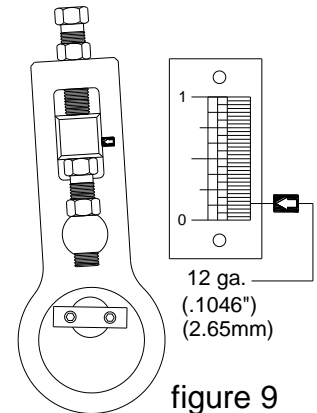

figure 9

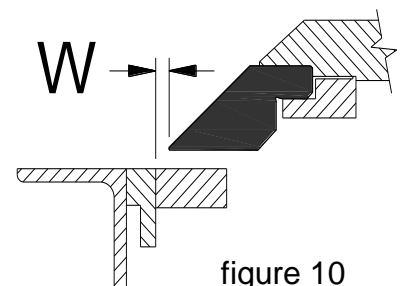

figure 10



figure 11



4. Turn on the main disconnect switch (fig. 12). (The white "POWER" light will be lit.)
5. Press the "PUMP START" button to energize the pump and motor.
6. Set the angle indicator to the desired degree of bend. (fig. 13)
7. Set the Bend selector switch to "INCH".
8. Load the material into the front of the machine and lower the clamping beam so that the bend line on the material just sticks out from beneath the die fingers.
9. Press the joystick to the bend position.
10. After the bend has been made, remove the piece part. If making many pieces with the same dimension, use the back gauge to eliminate scribing bend lines each time.



figure 12



figure 13



OPERATION – AUTO CYCLE

⚠ CAUTION: Always wear proper eye protection with side shields, safety footwear, and leather gloves to protect from burrs and sharp edges. When handling large heavy material make sure they are properly supported.

⚠ CAUTION: Keep hands and fingers clear of the clamping beam. Stand off to the side of the machine to avoid getting hit with the bending apron as it comes up to bend.

1. Set the clamping beam to the thickness of the material you will be bending. (fig. 14) shows the adjusting bolts set for 14 ga. as read on the gauge. See the section on clamping beam pressure adjustments for setting the bolts.
2. Adjust the finger setback or “W” dimension (fig. 15) with the formula: $W = (\text{material thickness}) \times 1.2$. This will help keep the material from tearing when the bend is made. To make the adjustment, loosen the setscrews on both ends of the machine as indicated with the arrow in (fig. 16). Turn the handwheels to set the “W” dimension along the full length of the clamping beam.
3. If you are doing box and pan braking, arrange the fingers accordingly. (See the section on **finger removal**).

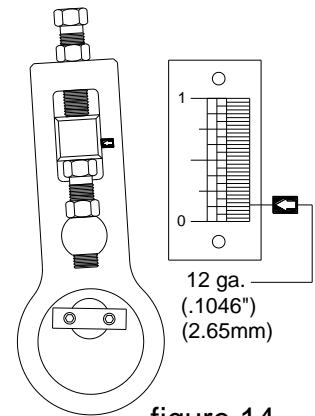

figure 14

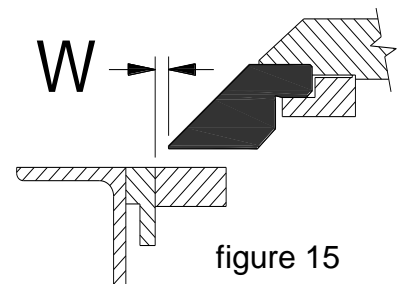

figure 15



figure 16



4. Turn on the main disconnect switch (fig. 17). The white “**POWER**” light will be lit.
5. Press the “**PUMP START**” button to energize the pump and motor.
6. Set the angle indicator to the desired degree of bend. (fig.18)
7. Set the Bend selector switch to “**AUTO**”.
8. Load the material into the front of the machine and lower the clamping beam so that the bend line on the material just sticks out from beneath the die fingers.
9. Press the joystick to the bend position. The bend apron will automatically bend the piece part to the desired angle and return to the start position.
10. After the bend has been made, remove the piece part. If making many pieces with the same dimension, use the back gauge to eliminate scribing bend lines each time.



figure 17



figure 18



FINGER REMOVAL

⚠ WARNING: Make sure the electrical disconnect is **OFF** before working on the machine.

When doing box and pan braking it will be necessary to remove and relocate finger assemblies. This is done by loosening the center socket capscrew as shown in (fig. 19), gripping the finger assembly firmly, and either removing or repositioning it. There are (3) 3" (76.2mm), (2) 4", (101.6mm), (5) 5" (127mm), and (1) 6" (152.4mm) fingers to accommodate your bending needs.

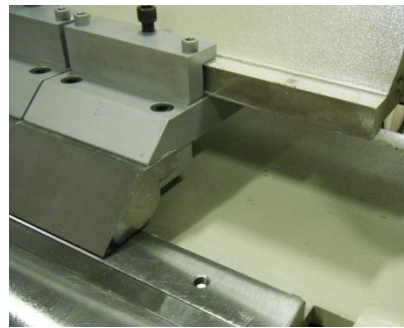

figure 19

A properly adjusted brake should form a consistent bend from end to end. To correctly align your brake, check the following three adjustments.

BENDING ALLOWANCE

In order to bend sheet metal accurately, you will need to consider the total length of each bend. This is referred to as bend allowance. Subtract the bend allowance from the sum of the outside dimensions of the piece part to obtain the actual overall length or width of the piece. Because of differences in sheet metal hardness, and whether the bend is made with the grain or against it, exact allowances must sometimes be made by trial and error. However, bend allowances for general use can be obtained from metal working books or from the Internet.

UNDERSTANDING SPRINGBACK

Springback, also known as elastic recovery, is the result of the metal wanting to return to its original shape after undergoing compression and stretch. After the bending leaf is removed from the metal and the load is released, the piece part relaxes, forcing the bent portion of the metal to return slightly to its original shape. The key to obtaining the correct bend angle is to over bend the metal a little and allow it to spring back to the desired angle. All metals exhibit a certain amount of spring back.



MATERIAL SELECTION

⚠ CAUTION: It must be determined by the customer that materials being processed through the machine are NOT potentially hazardous to operator or personnel working nearby.

When selecting materials keep these instructions in mind:

- Material must be clean and dry. (without oil)
- Material should have a smooth surface so it processes easily.
- Dimensional properties of material must be consistent and not exceed the machine capacity values.
- Chemical structure of material must be consistent.
- Buy certificated steel from the same vendor when possible.

MACHINE ADJUSTMENTS

A properly adjusted brake should form a consistent bend from end to end. To correctly align your brake, check the following three adjustments.

- Clamp alignment (end to end)
- Clamping beam pressure adjustment
- Radius set back

If none of the three adjustments listed above work, contact Baileigh Industrial at (920) 684-4990 and ask for the service department.

To test your brakes alignment, make several sample strips; both 2" x 3" and near full length. Use material the same thickness as will be used in your application.

Clamp Alignment (end to end)

Make a 90° test bend about 4" in from each end of the machine. Stack the bent strips on top of each other and check that they are bent to the same degree.

If a strip is over bent, increase the setback distance on that side. If a strip is under bent, decrease the setback distance on that side. Again, move the fingers past the desired set back point, and then forward to remove the slack.



Clamping Beam Pressure Adjustments

Test clamping pressure by placing a small strip about 4" from each end of the brake, and closing the clamp. Check to make sure the clamping pressure is enough to keep the material from slipping and no more.



IMPORTANT: Excessive clamping pressure can “pre-load and permanently distort the brake.

To increase the clamping pressure, follow the steps below: (fig. 20)

1. Back off locknuts “B” and “D”.
2. Turn adjusting bolt “A” ccw (**counterclockwise**) to back off about 1/16" from the square slider shaft.
3. Turn bolt “C” ccw (**counterclockwise**) until the square slider shaft pushes against the bottom of bolt “A”.
4. Retighten locknuts “B” and “D” and check the clamping pressure. Repeat the above steps for more clamping pressure.
5. To decrease the clamping pressure, reverse the above adjusting bolt procedure. (Use the measuring gauge to keep track of the material thickness.)

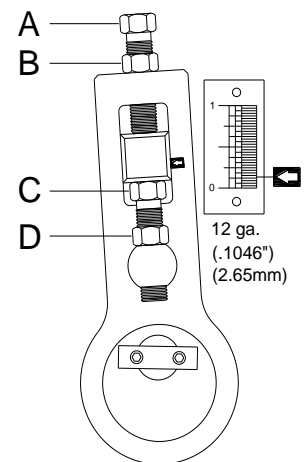

figure 20

Set Back / Radius

“Set back” is how far the front edge of the fingers are from the inside edge of the apron (fig. 21). The amount of setback depends on the thickness of the material to be formed.

- For most applications, adjust the finger setback with the formula: “Setback” = material thickness x 1.2. This will help keep the material from tearing when the bend is made. For 16 ga. (.062”) or heavier material, it may be desired to adjust the setback up to 2 times the material thickness to achieve the desired results.
- To make the adjustment, loosen the setscrews on both ends of the machine as indicated with the arrow in (fig. 22). Turn the hand wheels to adjust the “Set back dimension” along the full length of the clamping beam. First move the fingers back, passed the desired “set back”, and then forward to remove any slack. Double check that the clamping pressure is minimal.
- Re-tighten the two setscrews and double check the setback distance.

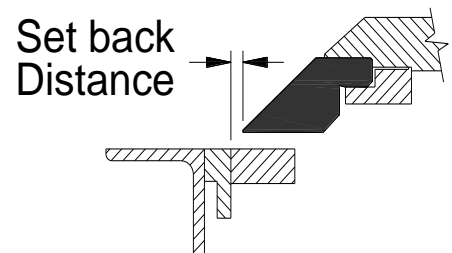

figure 21



figure 22



FACTORY SETTINGS for CLAMPING BEAM

The factory settings for 14 ga. (.0747" [1.897mm]) mild steel. To return your machine to these settings, the arrow for the material thickness gauge needs to be set at slightly less than the 5/64" increment as shown in the figure 23. The right side of the gauge is divided into 1/32"s of an inch. To decrease the reading on the gauge:

1. Back off locknuts "B" and "D".
2. Turn Adjusting bolt "A" ccw (**counterclockwise**) to back off about 1/16" from the square slider shaft.
3. Turn bolt "C" ccw (**counterclockwise**) until the square slider shaft pushes against the bottom of bolt "A".
4. Check the reading on the gauge. It should be less than it was. Repeat steps 2 and 3 if necessary to bring you down to .0747" (1.897mm).
5. If bending 16 ga. (.0598" [1.519mm]) line up the arrow to read slightly less than 1/16" on the gauge.
6. When bolts "A" and "C" are tight against the square slider and you have the gauge set properly, tighten locknuts "B" and "D".
7. To increase the dimension on the gauge, reverse the above adjusting bolt procedure.

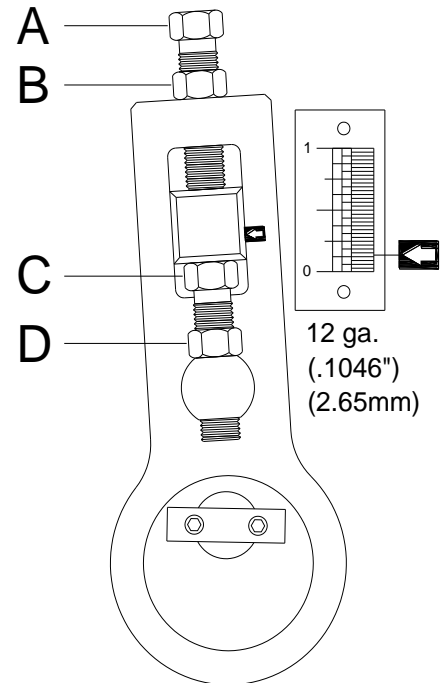

figure 23



CLAMPING BEAM ROLLER SWITCH SETTING

The position of the clamping beam is monitored by two roller actuated micro switches. If the collar has slipped or been readjusted and you need to return to factory settings:

1. Lower the clamping beam.
2. Loosen the set screw on the collar (fig. 24).
3. Rotate the collar until the dimension (fig. 25) from the tip of the actuator bolt to the wall is reached. (clamping beam down)
4. Tighten the collar.
5. Raise the clamping beam.

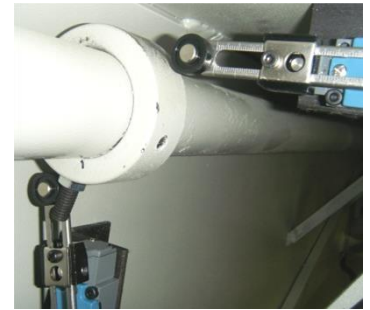

figure 24

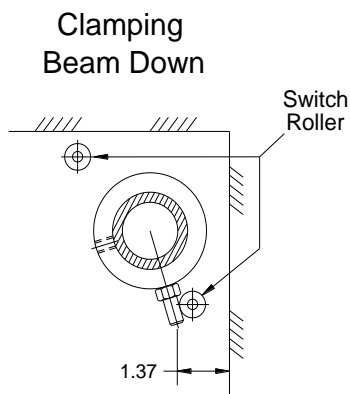

figure 25

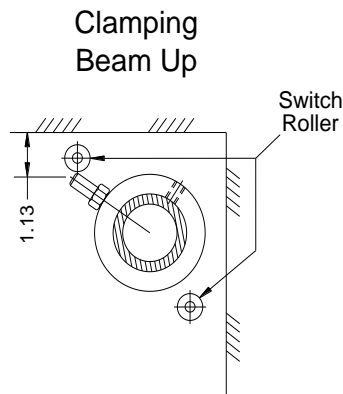

figure 26



figure 27

6. Check the “clamping beam up” dimension (fig. 26).
7. Make sure the micro switches are secure and have not been repositioned.



Top Leaf Adjustment



IMPORTANT: The top leaf and bending leaf adjustments were made at the factory based upon full capacity (length and thickness) mild steel. Additional adjustments are generally not needed. Different materials and material strength and hardness variation may require adjusting the leaf to obtain a satisfactory bend.

Normal bending should provide a consistent bend angle (A) over the entire length of the material. If the angle remains open (B) in the middle of the material, the leaf may need to be adjusted to reduce bend angle variation.

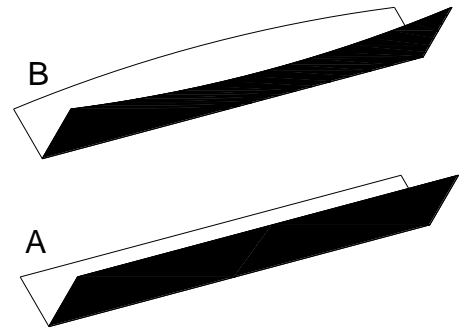

Note: The brake needs to be leveled and secured to the floor to provide consistent accurate results.

Crowning adjustment is made by tightening or loosening the center leaf nuts (C and D).

1. Move the clamp handles to the forward position.
2. If the bend is open on the middle as in example (B), evenly tighten the top leaf center truss nut (C) and the lower leaf center truss nut (D) 1/2 turn each and test the bend angle.
3. Repeat the test bend and continue to adjust until the bend is even over the entire length of the material.

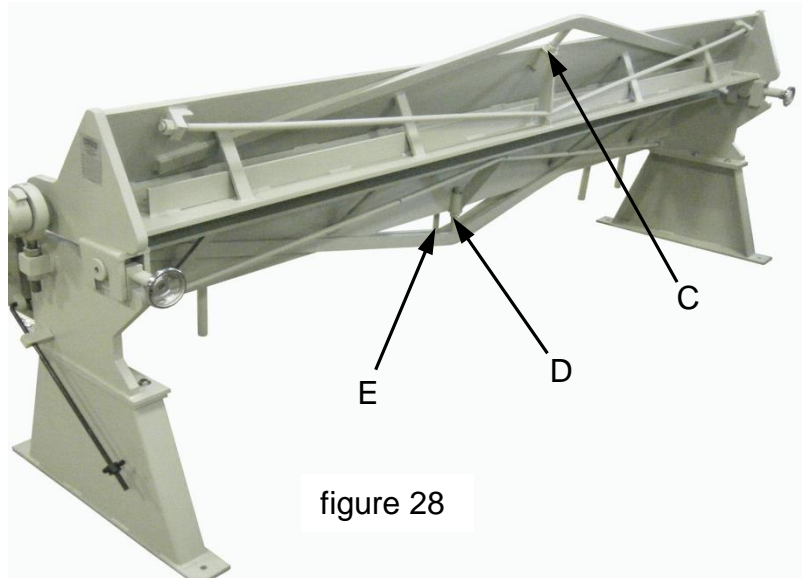

figure 28



Bending Leaf Edge Alignment

Bending accuracy is dependent on the top surface of the bending leaf and the attached bending wing being flush with the top face of the clamping block when the bending leaf is in the lowered position.

1. Adjust bending leaf center truss nut (E) up or down as needed until the center of the bending leaf is perfectly aligned (on the same plane) with the clamping leaf edge.
2. Loosen the hinge to leaf bolts (F) only slightly to allow for the leaf to move with the adjusting bolt (G).
3. Adjust bending leaf ends with hinge adjustment bolts (G) up or down as needed until the ends of the bending leaf are perfectly aligned (on the same plane) with the clamping leaf edge.
4. Repeat these steps as needed until the entire length of the bending leaf is perfectly aligned (on the same plane) with the clamping leaf edge.
5. Tighten the hinge bolts (F) after adjustment.

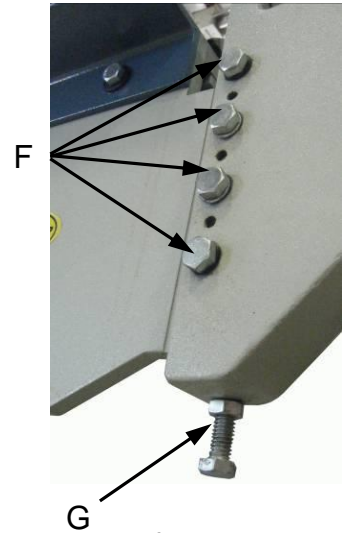

figure 29



LUBRICATION AND MAINTENANCE

 **WARNING:** Make sure the electrical disconnect is OFF before working on the machine.

Maintenance should be performed on a regular basis by qualified personnel. Always follow proper safety precautions when working on or around any machinery.

- Check daily for any unsafe conditions and fix immediately.
- Check that all nuts and bolts are properly tightened.
- On a weekly basis clean the machine and the area around it.
- Lubricate threaded components and sliding devices.
- Apply rust inhibitive lubricant to all non-painted surfaces.
- Lubricate the machine with recommended grease every 8 working hours using the grease gun provided. Recommended Grease (or equivalent) Esso Beacon 2, OR Shell Alvania Grease R2.
- Using an oil can with good quality #30W oil, apply 5-6 drops into each port. Repeat weekly or more often depending on usage. Wipe off any excess oil.

Storing Machine for Extended Period of Time

If this machine is to be inactive for a long period of time, prepare the machine as follows:

- Disconnect the electrical supply from the power panel.
- Clean and grease the machine.
- Cover the machine.



Note: Proper maintenance can increase the life expectancy of your machine.



Hydraulic Oil

The hydraulic oil is the primary medium for transmitting pressure and also must lubricate the running parts of the pump.

1. Use hydraulic oil #68 SHELL BRAND or an equivalent with similar specifications.
2. Keep hydraulic reservoir filled to 90% of capacity.
3. **DO NOT** rely totally on the oil gauge as they can sometimes indicate an incorrect level reading. Do a visual inspection with the oil fill cap removed as well.
4. A shortage of hydraulic oil will cause hydraulic system breakdown to major mechanical components due to overheating.
5. Change the hydraulic oil every 12 months along with the oil filter.

Oil Disposal

Used oil products must be disposed of in a proper manner following your local regulations.



HYDRAULIC TANK

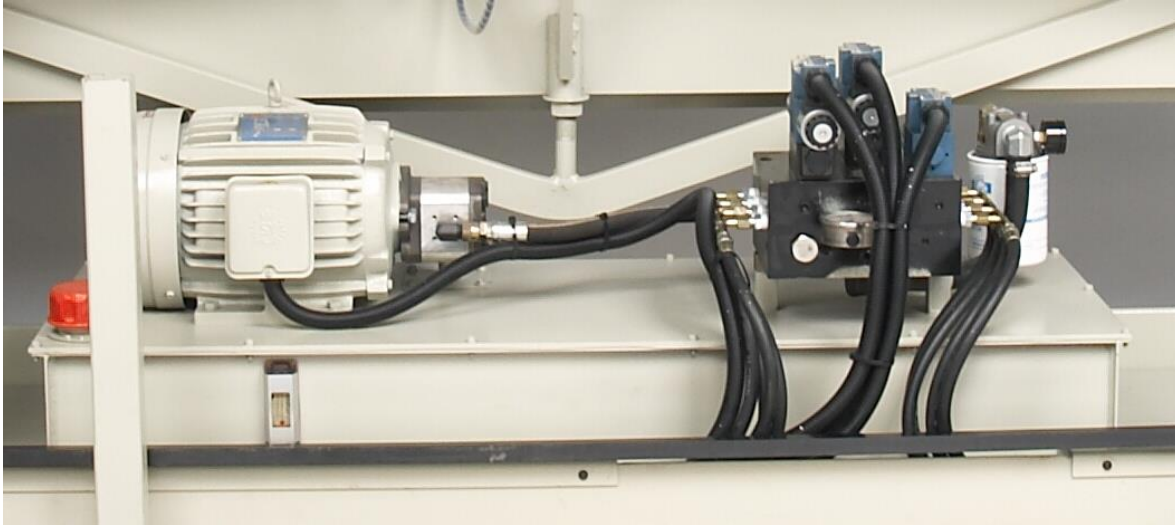

Hydraulic Parts Identification

Item	Description	Part No.	Qty.
1	Check Valve	CV10W	1
2	Relief Valve	RV11A 30AL	1
3	Solenoid Valve	4WE6D-E-D24	1
4	Directional Control Valve	4WE6E60/EG24	1
5	Solenoid Valve	4WE6J60/EG24	1
6	Counter Balance Valve	MST-02P	1
7	Mod. Pilot Operated Check Valve	MPC-02W	1
8	Pressure Gauge	AT-63, 250 Kg	2
9	Hydraulic Pump	2GG1POSRPO8E15	1
10	Electric Motor	3hp, 220/440V, 60Hz	1
11	Hydraulic Cylinder – Clamping	80mm X 160mm stroke	2
12	Hydraulic Cylinder – Bending	50mm X 350mm stroke	2
13	Strainer	SFF-08	1
14	Air Breather	HY-08	1
15	Oil Level Gauge	LG-3A	1
16	Strainer	CG050-P10/70134	1



HYDRAULIC SCHEMATIC

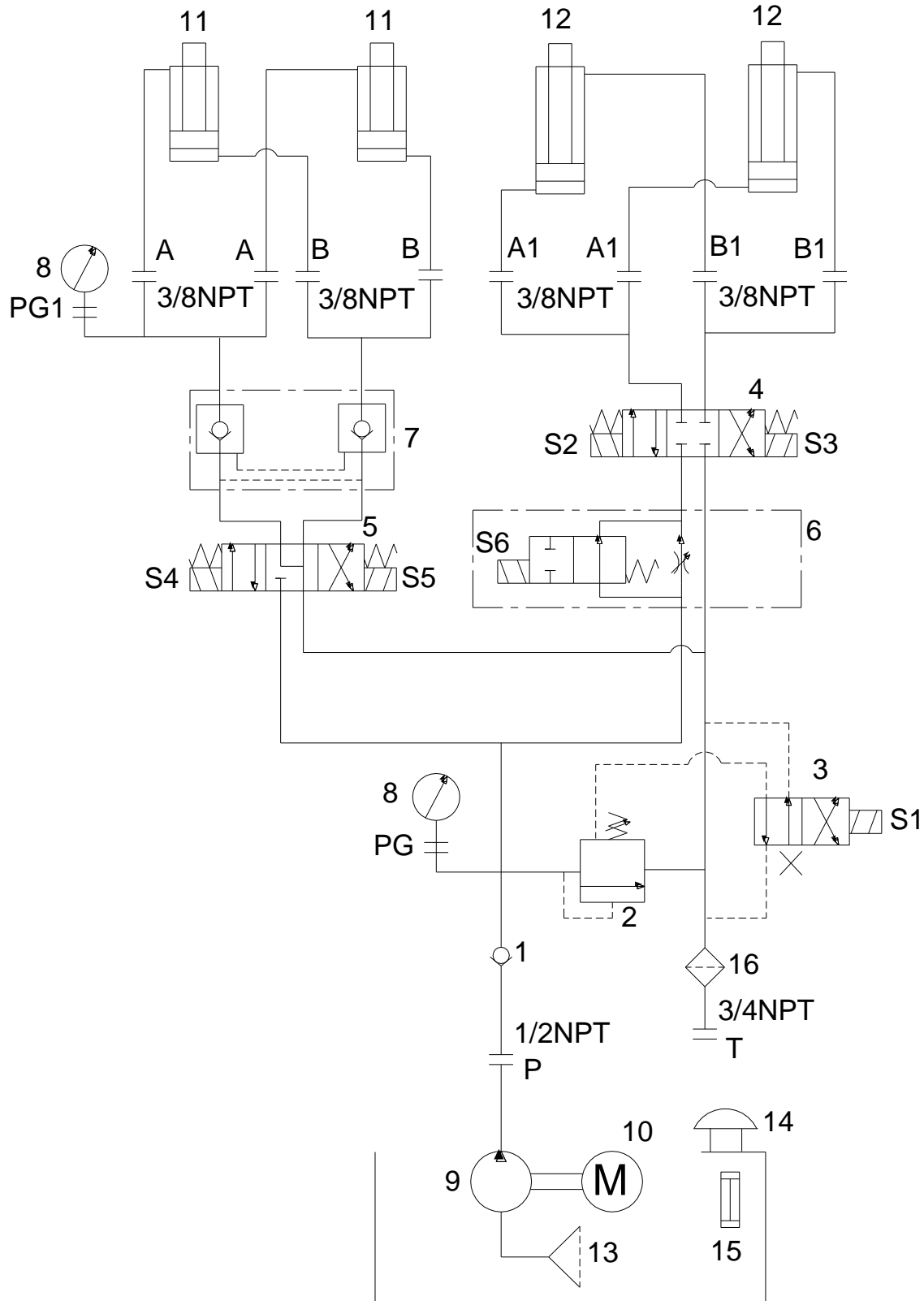



MANIFOLD BLOCK

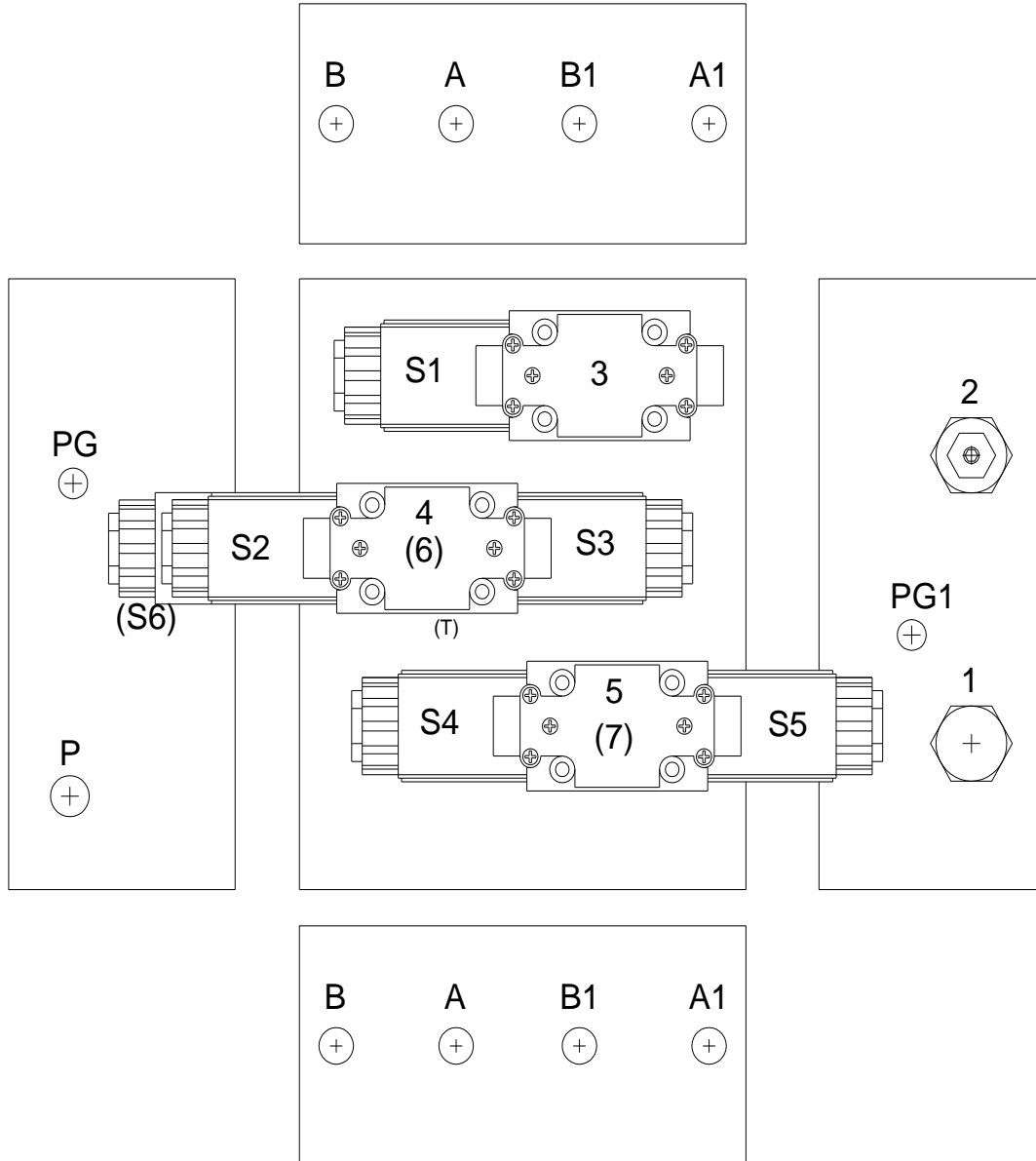

M \ S	S1	S2	S3	S4	S5	S6
CLAMP	▲			▲		
SLOW BEND	▲	▲				▲
FAST BEND	▲	▲				
FAST RELEASE	▲		▲			
SLOW RELEASE	▲		▲			▲
UNCLAMP	▲				▲	



FRAME PARTS DIAGRAM

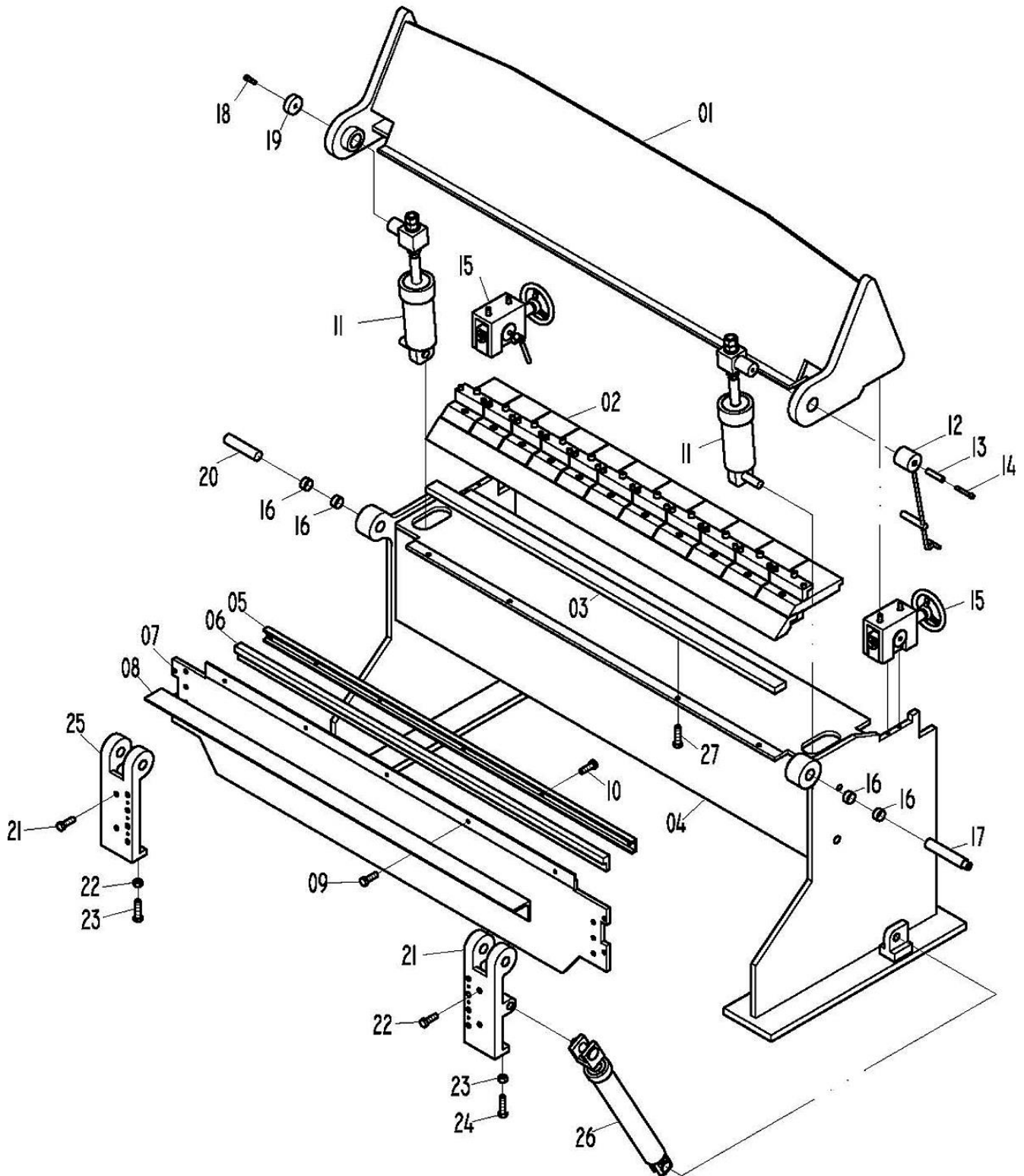



Frame Parts List

Item	Description
1	Clamping Beam Assembly
2	Upper Blade Assembly
3	Bottom Die
4	Bottom Base Assembly
5	Clamping Bar
6	Insert Bar
7	Bending Leaf
8	Angle Bar
9	Screw
10	Screw
11	Clamping Hydraulic Cylinder
12	Dog
13	Pipe Spacer
14	Screw
15	Clamping Beam Adjusting Assembly
16	Bearing
17	Hinge Pin – On Side
18	Screw
19	Shaft Filler Washer
20	Hinge Pin – Off Side
21	Hinge – On Side
22	Screw
23	Nut
24	Screw
25	Hinge – Off Side
26	Folding Hydraulic Cylinder
27	Screw



FINGERS PARTS DIAGRAM

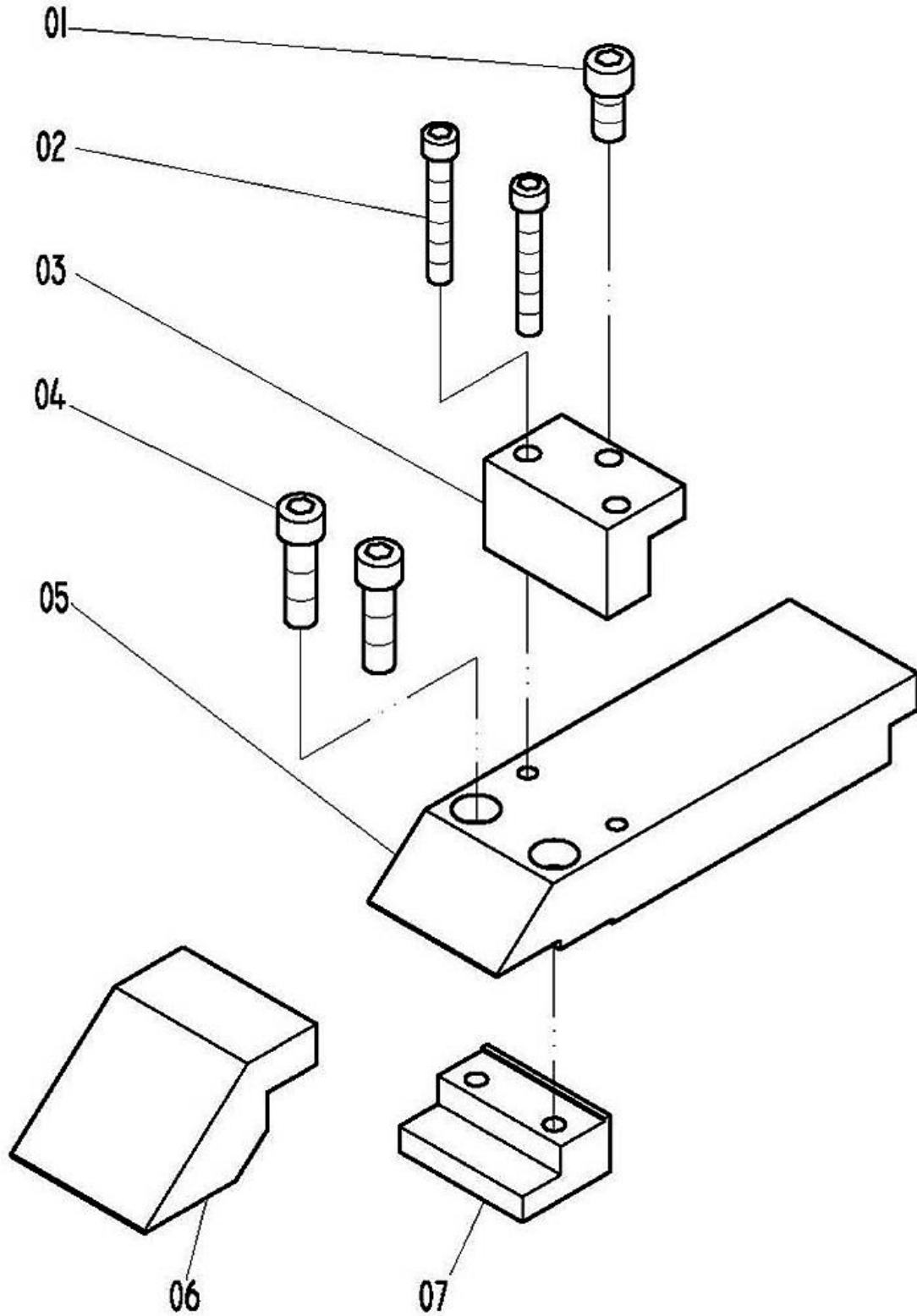



Fingers Parts List

Item	Description
1	Screw
2	Screw
3	Clamping Holder-Up
4	Screw
5	Upper Blade Base
6	Finger Blade
7	Clamping Holder-Bottom

FINGER BLADE SIZES – INCH (mm)	3" (76)	4" (102)	5" (127)	6" (152)
QTY. OF FINGERS	6	5	10	2



SETBACK PARTS DIAGRAM

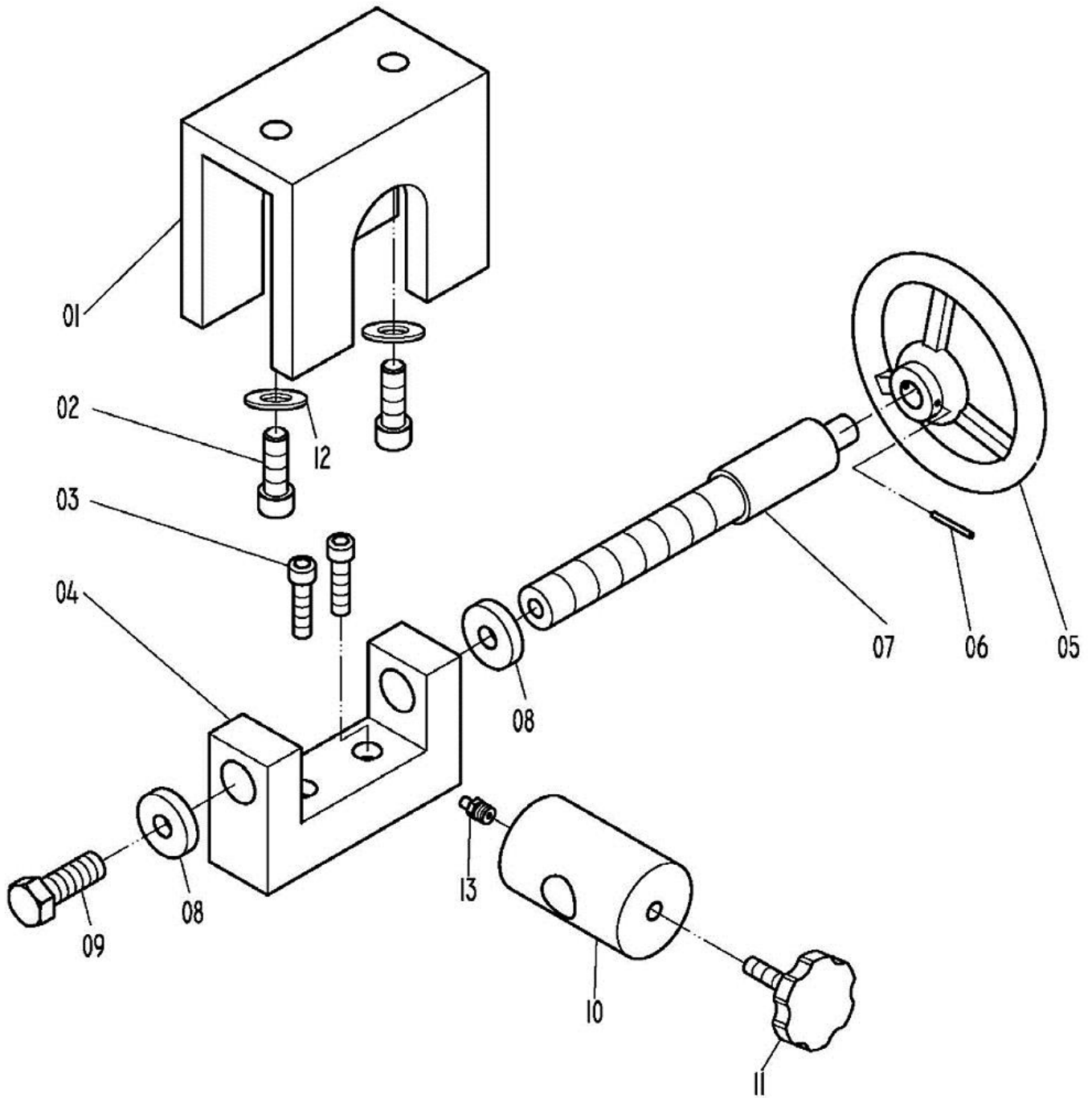



Setback Parts List

Item	Description
1	Holder
2	Screw
3	Screw
4	U Style Base
5	Hand Wheel
6	Roll Pin
7	Adjusting Screw
8	Shaft Filler Washer
9	Screw
10	Adjusting Nut
11	Bakelite Hand Knob
12	Washer
13	Grease Fitting



CLAMPING CYLINDER PARTS DIAGRAM

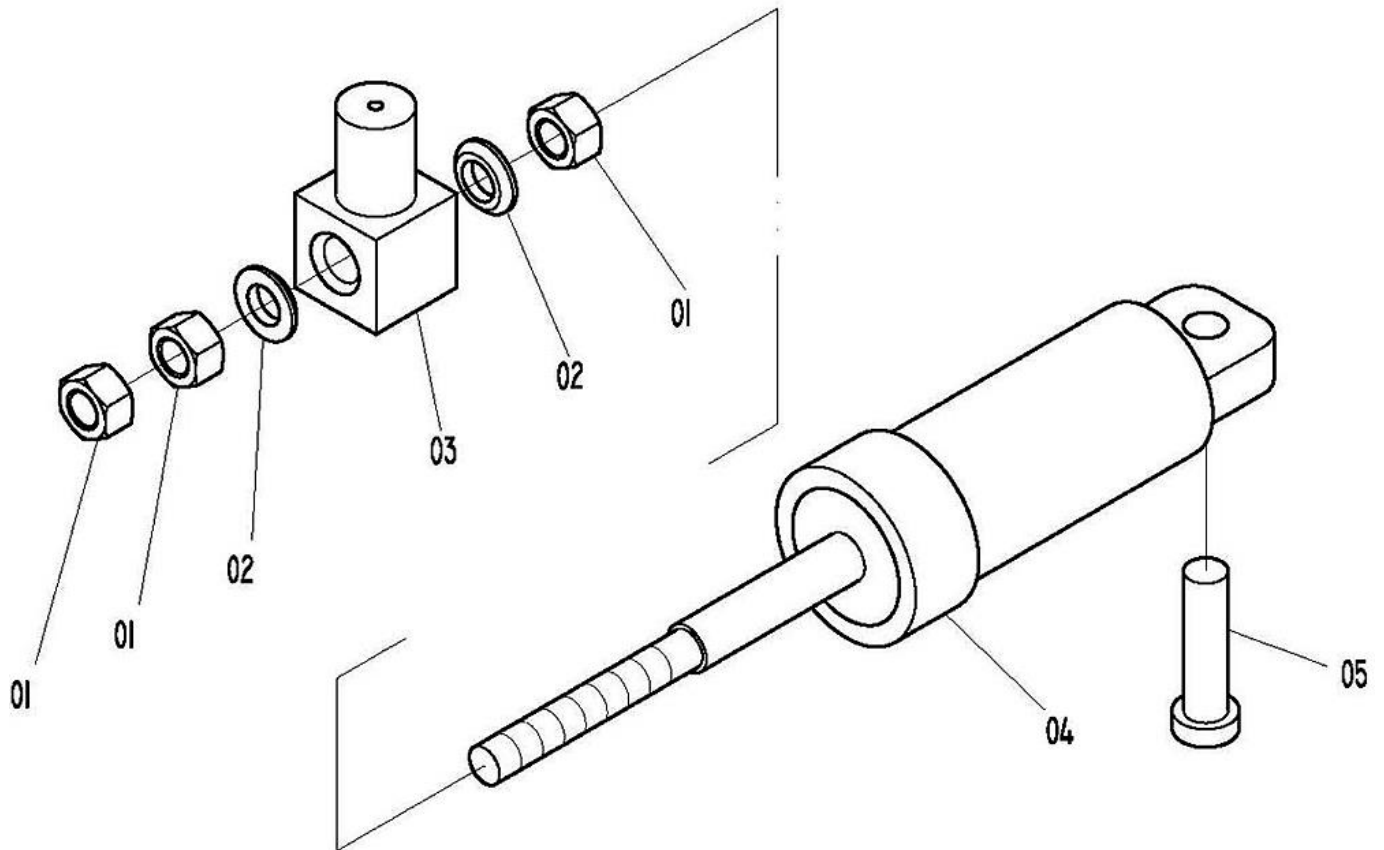

Clamping Cylinder Parts List

Item	Description
1	Nut
2	Washer
3	Swivel Pin
4	Cylinder
5	Pin



BENDING CYLINDER PARTS DIAGRAM

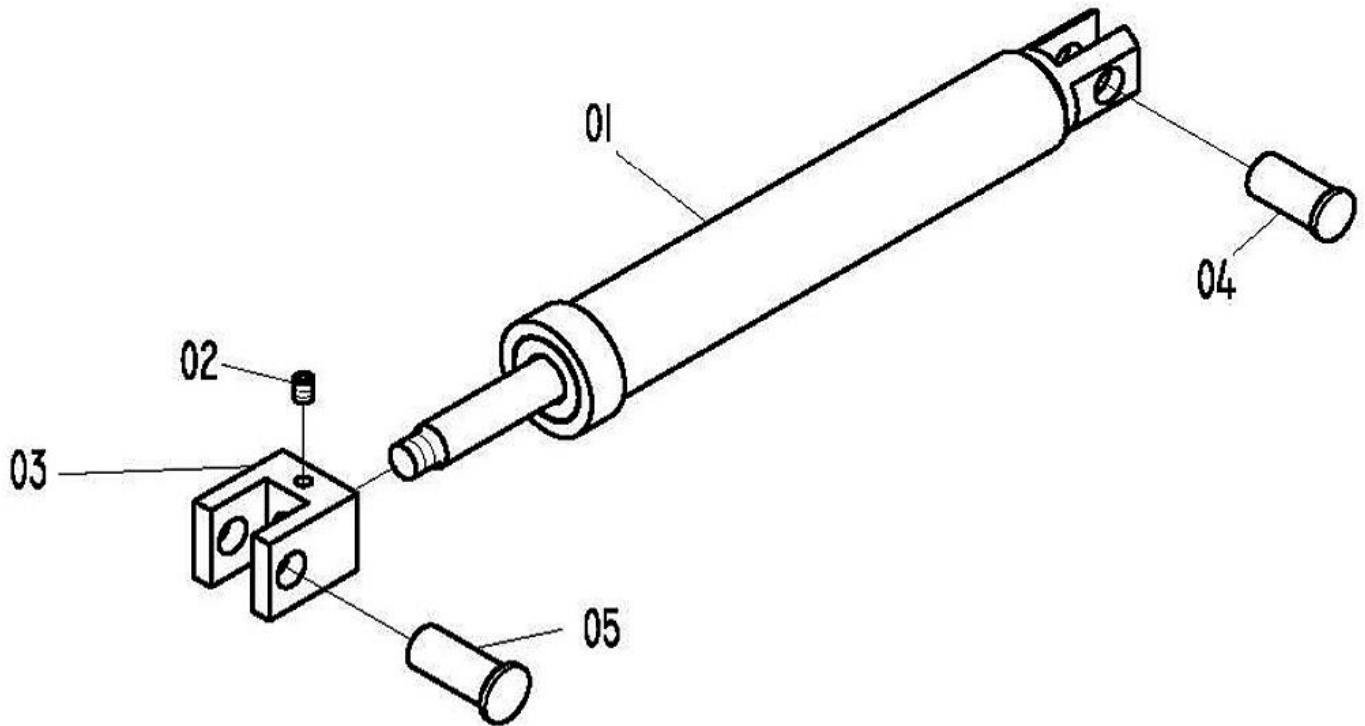

Bending Cylinder Parts List

Item	Description
1	Cylinder
2	Set Screw
3	Clevis
4	Cylinder Pin
5	Clevis Pin



BACK GAUGE PARTS DIAGRAM

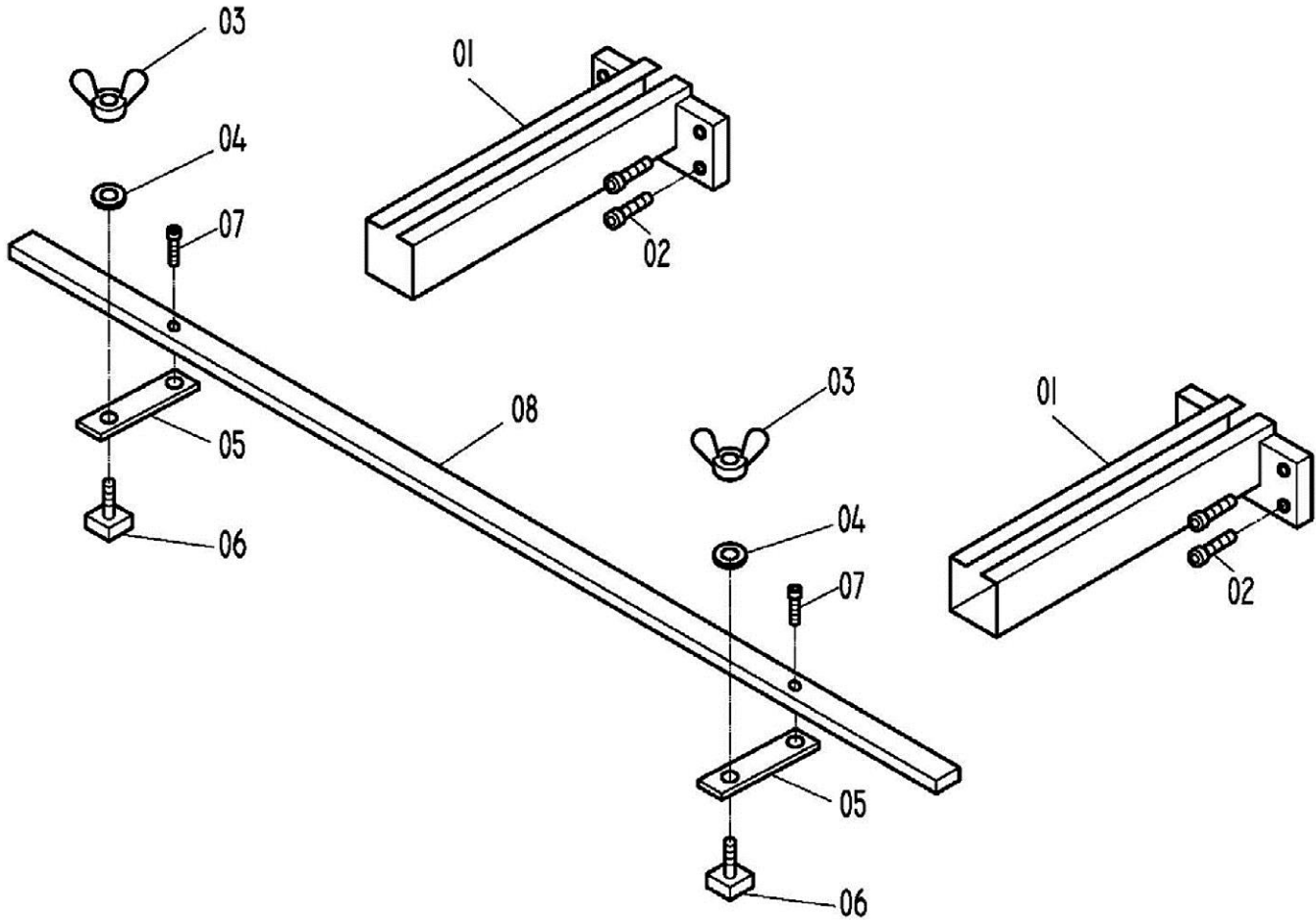

Back Gauge Parts List

Item	Description
1	Back Arm Extend
2	Screw
3	Wing Nut
4	Washer
5	Connecting Plate
6	T Screw
7	Screw
8	Stop Plate



ELECTRICAL COMPONENTS

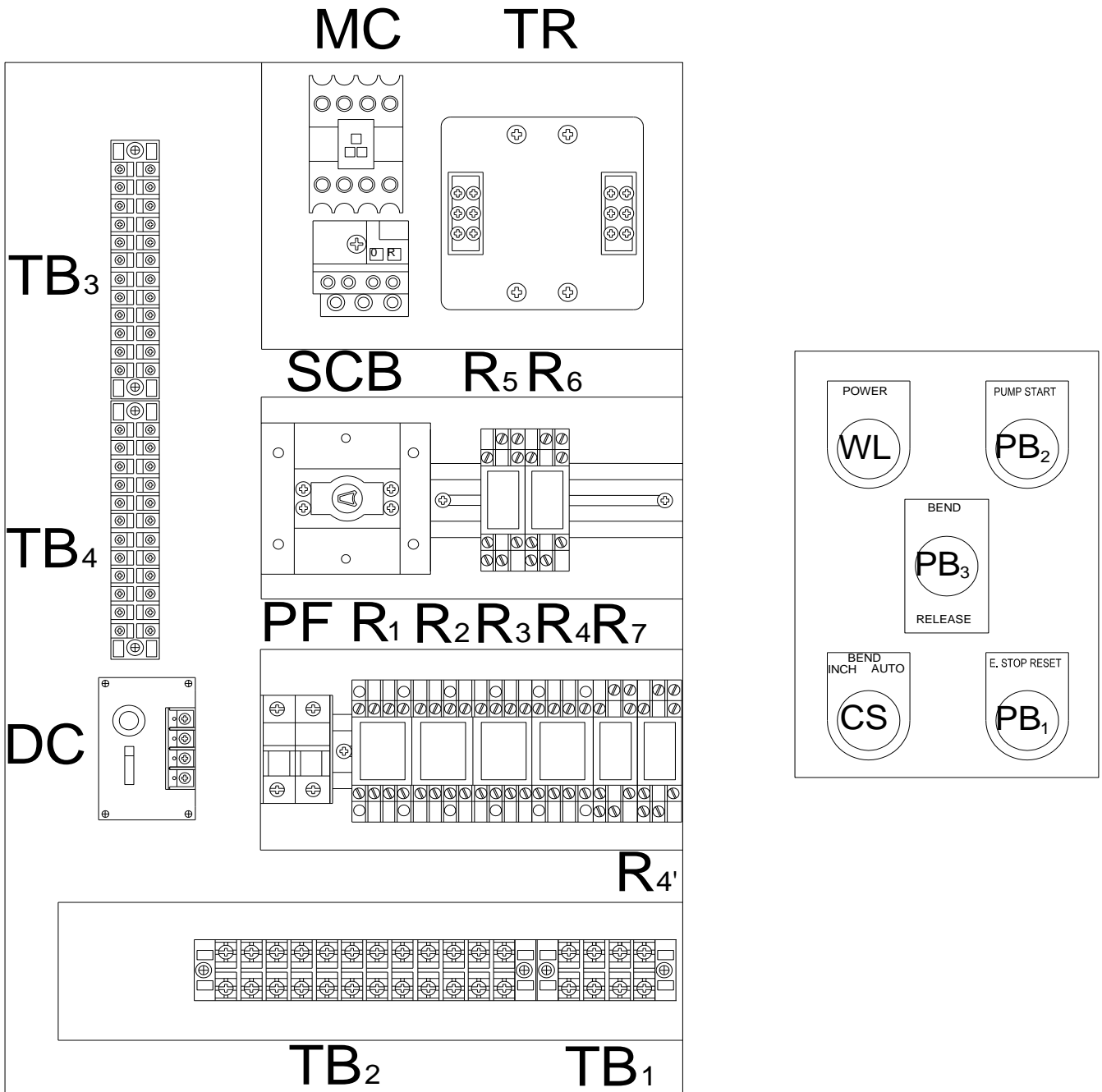



Electrical Parts Identification

Item	Description	Part No.
SCB	Main Switch	P1-25
MC, OL	Magnetic Switch	HUO-11 24VAC 10A
TR	Transformer	1Ø 220-440/24V 80VA 60Hz
PF1, PF2	Fuses	10*30mm 2A, 6A
DC	Power Supply	DC 24V 8A 2000uf
R1 – R4	Power Relay	MY-4 AC 24V
R5 – R7, R4'	Power Relay	MY-2 AC 24V
TB1	Terminal Buss	4P 30A
TB2	Terminal Buss	12P 30A
TB3, TB4	Terminal Buss	12P 15A
WL	Pilot Light	30Ø 24V White
PB1	Push Button	30Ø 1A1B Red (Lock)
PB2	Push Button	30Ø 1A 24V Green
PB3	Monolevel Switch	25Ø XD4 PA22
CS	Select Switch	30Ø 1A Black



TERMINAL ENDS

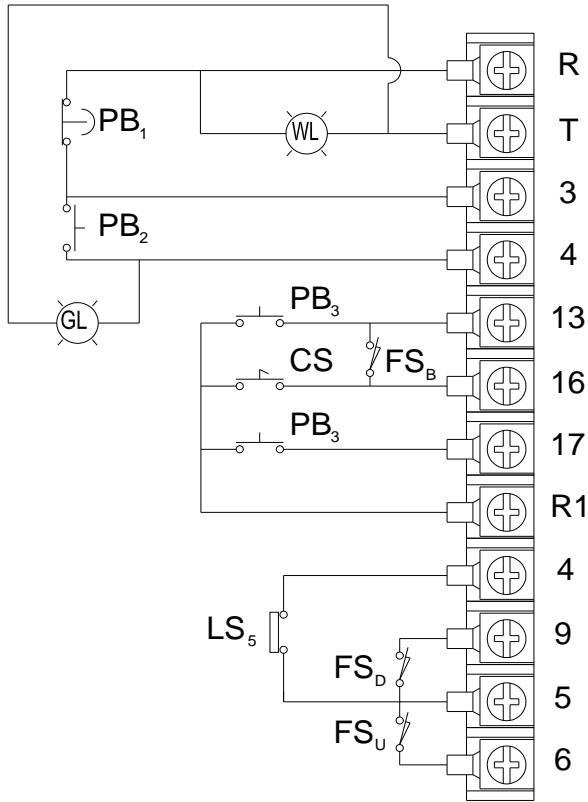

TB4

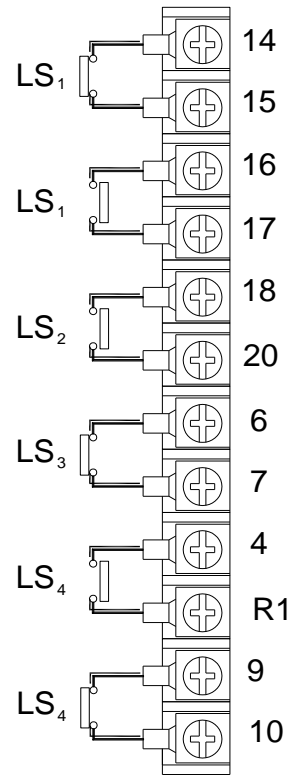

TB3

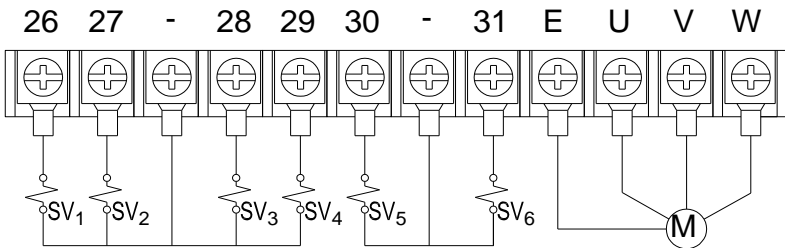

TB2

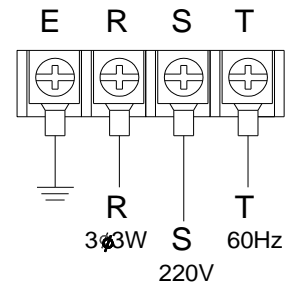

TB1



ELECTRICAL SCHEMATIC 1

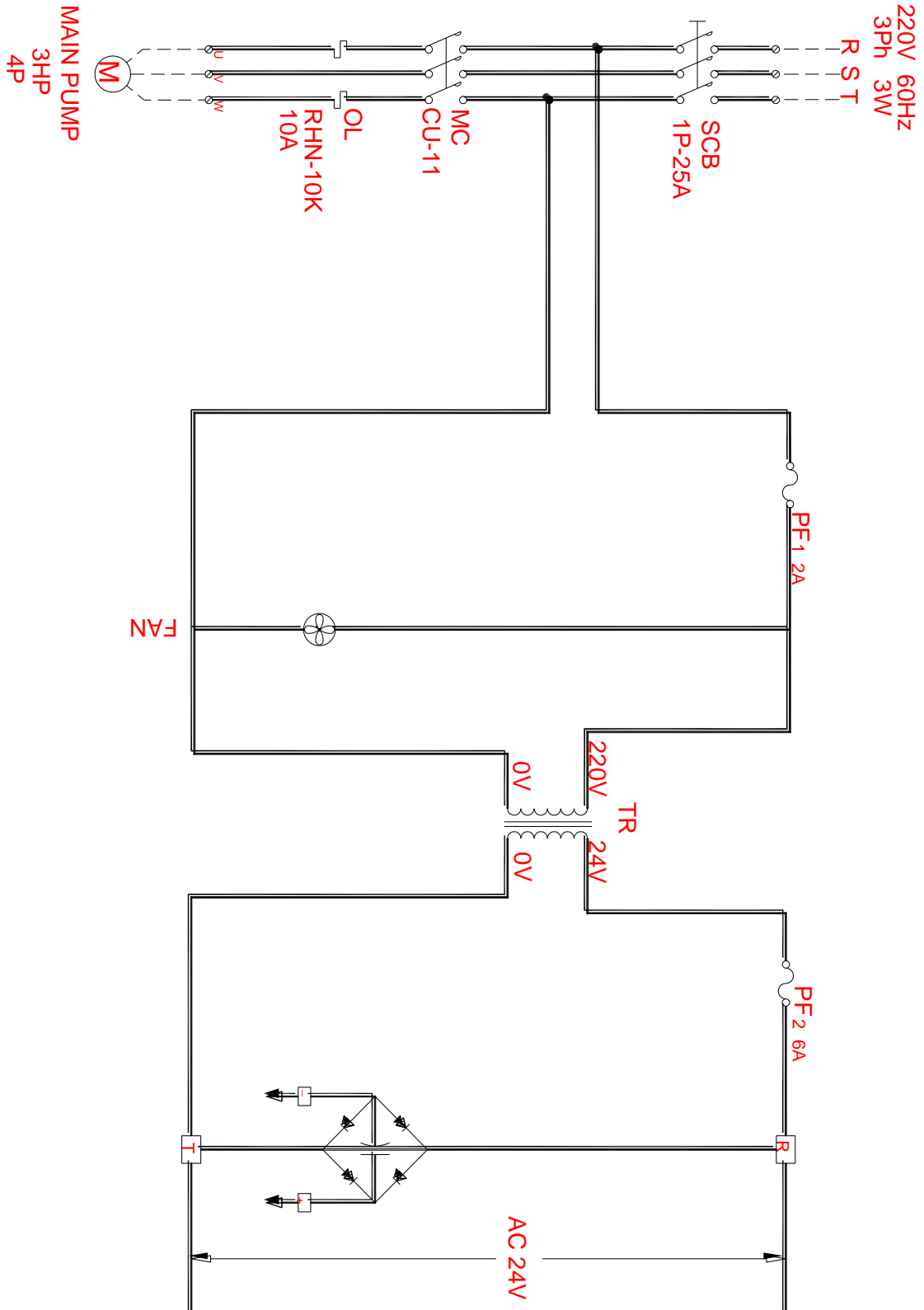



ELECTRICAL SCHEMATIC 2

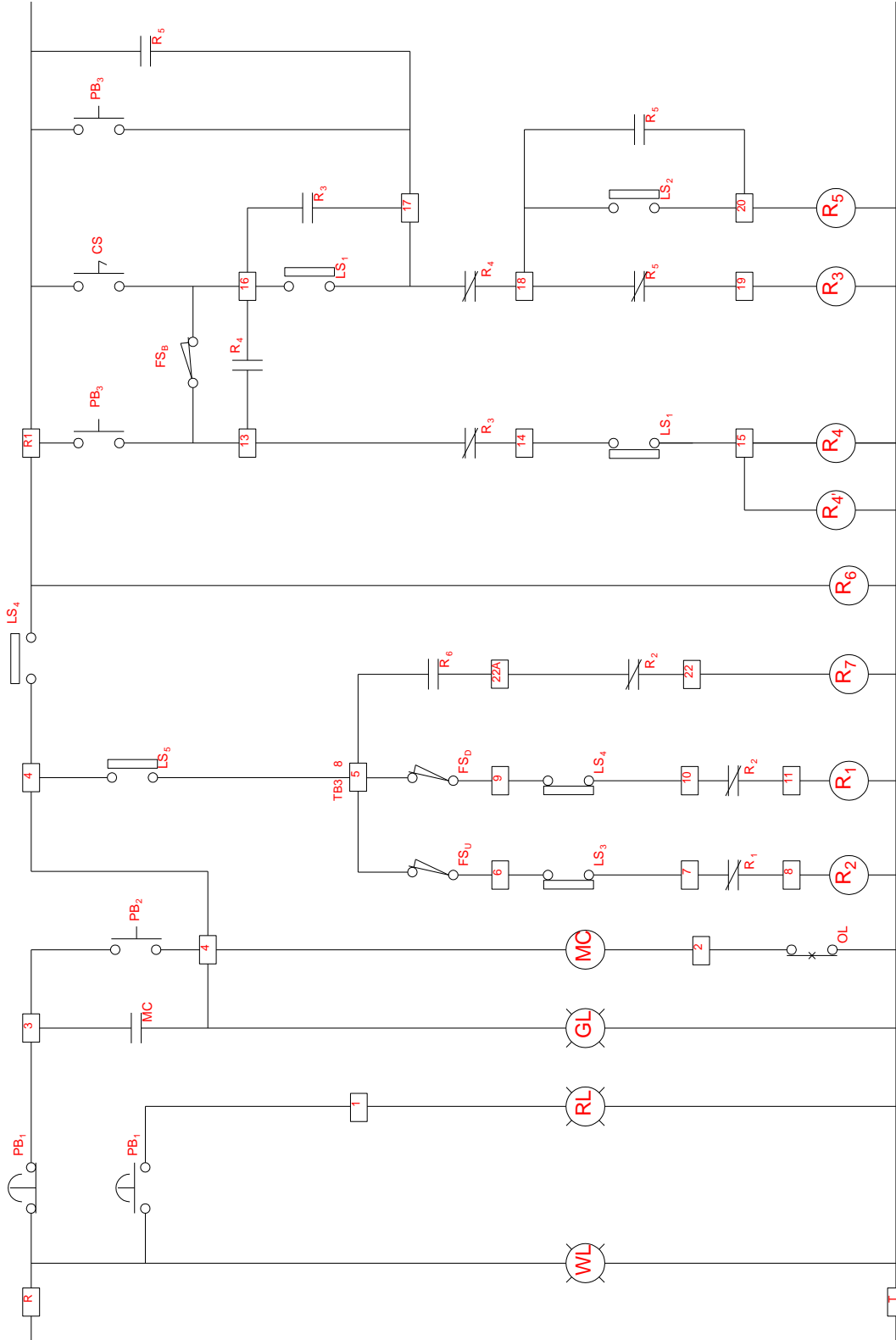



ELECTRICAL SCHEMATIC 3

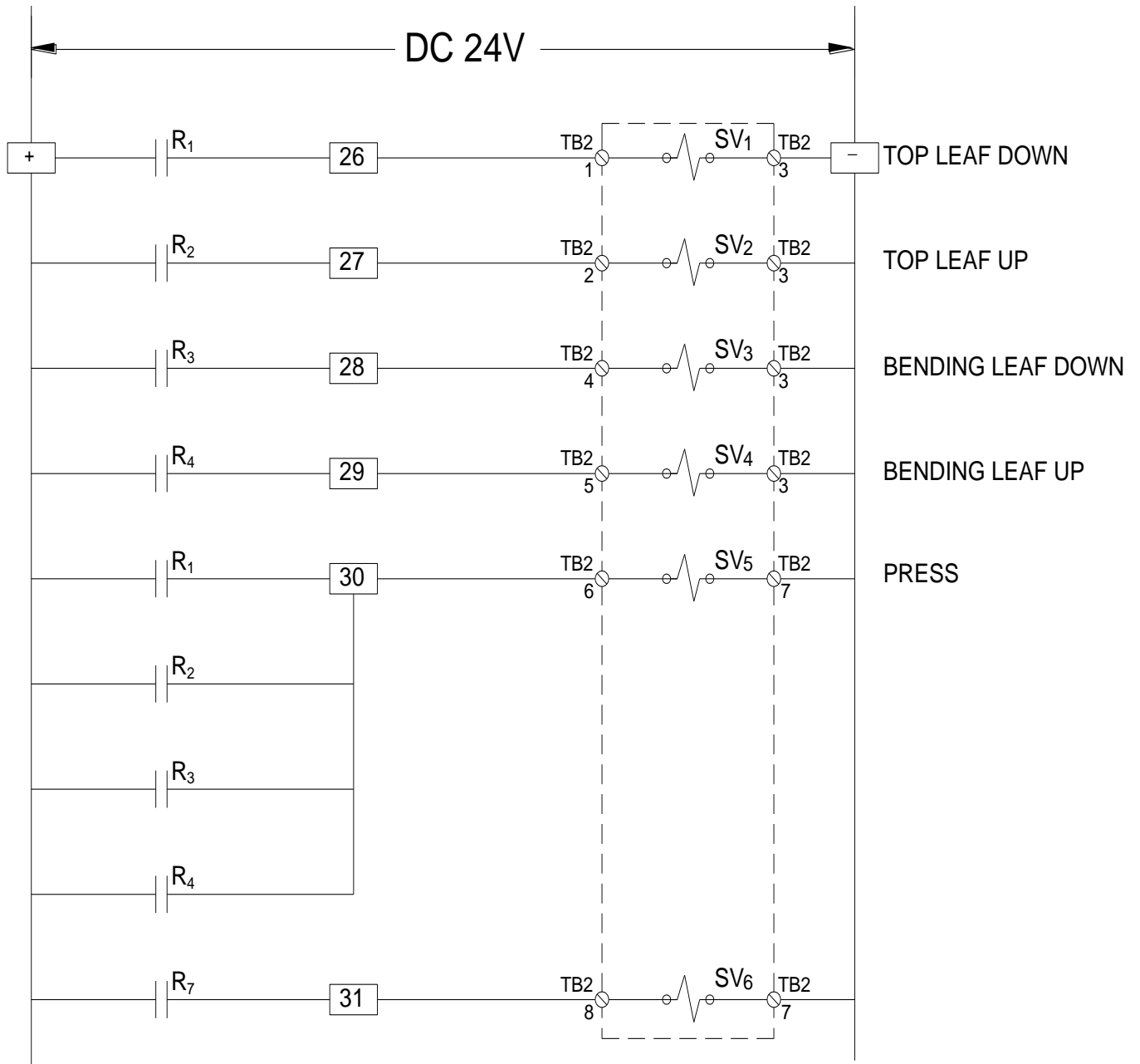



TROUBLESHOOTING

 **WARNING:** Make sure the electrical disconnect is OFF before working on the machine.

FAULT	PROBABLE CAUSE	REMEDY
Heavy resistance during bends.	Exceeding machine capacities.	Use materials within machine capabilities.
Bend radius is not consistent.	Brake blades and die are not aligned.	Adjust brake alignment.
Brake blade points are chipping.	Brake blades and die are not aligned.	Adjust brake alignment.
Piece part shows scoring marks after bend.	Brake blades or die has scratches.	Polish out scratches.

NOTES



BAILEIGH INDUSTRIAL, INC. 1625 DUFEEK DRIVE MANITOWOC, WI 54220

PHONE: 920. 684. 4990 FAX: 920. 684. 3944

www.baileigh.com

BAILEIGH INDUSTRIAL, INC. 1455 S. CAMPUS AVENUE ONTARIO, CA 91761

PHONE: 920. 684. 4990 FAX: 920. 684. 3944

BAILEIGH INDUSTRIAL LTD. UNIT D SWIFT POINT

SWIFT VALLEY INDUSTRIAL ESTATE, RUGBY

WEST MIDLANDS, CV21 1QH UNITED KINGDOM

PHONE: +44 (0)24 7661 9267 FAX: +44 (0)24 7661 9276

WWW.BAILEIGHINDUSTRIAL.CO.UK

BAILEIGH INDUSTRIAL GMBH HOFENER STRAÙE 64

70736 FELLBACH

DEUTCHSLAND

WWW.BAILEIGHINDUSTRIAL.DE

BAILEIGH INDUSTRIAL PTY. LTD.

P.O Box 1573, 126 MELROSE DRIVE TULLAMARINE,

VIC 3043 AUSTRALIA

WWW.BAILEIGHINDUSTRIAL.COM.AU