



# OPERATOR'S MANUAL



## 110 TON HYDRAULIC SHOP PRESS HSP-110M-HD AND HSP-110M-1500-HD

Baileigh Industrial, Inc.  
P.O. Box 531  
Manitowoc, WI 54221-0531  
Phone: 920.684.4990  
Fax: 920.684.3944  
[sales@baileigh.com](mailto:sales@baileigh.com)

REPRODUCTION OF THIS MANUAL IN ANY FORM WITHOUT WRITTEN APPROVAL OF BAILEIGH INDUSTRIAL, INC. IS PROHIBITED. Baileigh Industrial, Inc. does not assume and hereby disclaims any liability for any damage or loss caused by an omission or error in this Operator's Manual, resulting from accident, negligence, or other occurrence.



## Table of Contents

THANK YOU & WARRANTY .....	1
INTRODUCTION.....	3
GENERAL NOTES.....	3
SAFETY INSTRUCTIONS .....	4
SAFETY PRECAUTIONS .....	6
TECHNICAL SPECIFICATIONS .....	9
TECHNICAL SUPPORT .....	9
UNPACKING AND CHECKING CONTENTS.....	10
Cleaning .....	10
TRANSPORTING AND LIFTING .....	11
INSTALLATION.....	12
Anchoring the Machine.....	13
DIMENSIONS .....	15
GETTING TO KNOW YOUR MACHINE .....	16
ASSEMBLY AND SET UP .....	18
ELECTRICAL.....	20
Power cord connection: .....	21
OPERATION PREPLANNING .....	22
Workpiece Considerations.....	22
General Information.....	23
PRESS FUNCTIONS .....	24
On /Off Switch .....	24
Direction Control Valve.....	24
Pressure Gauge .....	25
Pressure Regulation Valve .....	25
Pressure Adjusting .....	25
Air Purge .....	26
Cylinder Positioning.....	26
Table Adjustment.....	27
Using the Machine:.....	28
OPERATION.....	30
UNDERSTANDING SPRINGBACK .....	31
MATERIAL SELECTION.....	31
LUBRICATION AND MAINTENANCE .....	32
Changing the Hydraulic Oil.....	33
Oil Disposal .....	33
OVERALL MACHINE PARTS DIAGRAM .....	34
Overall Machine Parts List.....	35
RAM PARTS DIAGRAM .....	36
Ram Parts List.....	37
ELECTRIC HYDRAULIC PUMP PARTS DIAGRAM.....	38
Electric Hydraulic Pump Parts List.....	39



ELECTRICAL SCHEMATIC.....	40
Electrical Parts List.....	40
TROUBLESHOOTING .....	41



## THANK YOU & WARRANTY

Thank you for your purchase of a machine from Baileigh Industrial. We hope that you find it productive and useful to you for a long time to come.

**Inspection & Acceptance.** Buyer shall inspect all Goods within ten (10) days after receipt thereof. Buyer's payment shall constitute final acceptance of the Goods and shall act as a waiver of the Buyer's rights to inspect or reject the goods unless otherwise agreed. If Buyer rejects any merchandise, Buyer must first obtain a Returned Goods Authorization ("RGA") number before returning any goods to Seller. Goods returned without a RGA will be refused. Seller will not be responsible for any freight costs, damages to goods, or any other costs or liabilities pertaining to goods returned without a RGA. Seller shall have the right to substitute a conforming tender. Buyer will be responsible for all freight costs to and from Buyer and repackaging costs, if any, if Buyer refuses to accept shipment. If Goods are returned in unsalable condition, Buyer shall be responsible for full value of the Goods. Buyer may not return any special order Goods. Any Goods returned hereunder shall be subject to a restocking fee equal to 30% of the invoice price.

**Specifications.** Seller may, at its option, make changes in the designs, specifications or components of the Goods to improve the safety of such Goods, or if in Seller's judgment, such changes will be beneficial to their operation or use. Buyer may not make any changes in the specifications for the Goods unless Seller approves of such changes in writing, in which event Seller may impose additional charges to implement such changes.

**Limited Warranty.** Seller warrants to the original end-user that the Goods manufactured or provided by Seller under this Agreement shall be free of defects in material or workmanship for a period of twelve (12) months from the date of purchase, provided that the Goods are installed, used, and maintained in accordance with any instruction manual or technical guidelines provided by the Seller or supplied with the Goods, if applicable. The original end-user must give written notice to Seller of any suspected defect in the Goods prior to the expiration of the warranty period. The original end-user must also obtain a RGA from Seller prior to returning any Goods to Seller for warranty service under this paragraph. Seller will not accept any responsibility for Goods returned without a RGA. The original end-user shall be responsible for all costs and expenses associated with returning the Goods to Seller for warranty service. In the event of a defect, Seller, at its sole option, shall repair or replace the defective Goods or refund to the original end-user the purchase price for such defective Goods. Goods are not eligible for replacement or return after a period of 30 days from date of receipt. The foregoing warranty is Seller's sole obligation, and the original end-user's exclusive remedy, with regard to any defective Goods. This limited warranty does not apply to: (a) die sets, tooling, and saw blades; (b) periodic or routine maintenance and setup, (c) repair or replacement of the Goods due to normal wear and tear, (d) defects or damage to the Goods resulting from misuse, abuse, neglect, or accidents, (e) defects or damage to the Goods resulting from improper or unauthorized alterations, modifications, or changes; and (f) any Goods that has not been installed and/or maintained in accordance with the instruction manual or technical guidelines provided by Seller.

**EXCLUSION OF OTHER WARRANTIES.** THE FOREGOING LIMITED WARRANTY IS IN LIEU OF ALL OTHER WARRANTIES, EXPRESS OR IMPLIED. ANY AND ALL OTHER EXPRESS, STATUTORY OR IMPLIED WARRANTIES, INCLUDING BUT NOT LIMITED TO, ANY WARRANTY OF MERCHANTABILITY OR FITNESS FOR ANY PARTICULAR PURPOSE ARE EXPRESSLY DISCLAIMED. NO WARRANTY IS MADE WHICH EXTENDS BEYOND THAT WHICH IS EXPRESSLY CONTAINED HEREIN.

**Limitation of Liability.** IN NO EVENT SHALL SELLER BE LIABLE TO BUYER OR ANY OTHER PARTY FOR ANY INCIDENTAL, CONSEQUENTIAL OR SPECIAL DAMAGES (INCLUDING, WITHOUT LIMITATION, LOST PROFITS OR DOWN TIME) ARISING FROM OR IN MANNER CONNECTED WITH THE GOODS, ANY BREACH BY SELLER OR ITS AGENTS OF THIS AGREEMENT, OR ANY OTHER CAUSE WHATSOEVER, WHETHER BASED ON CONTRACT, TORT OR ANY OTHER THEORY OF LIABILITY. BUYER'S REMEDY WITH RESPECT TO ANY CLAIM ARISING UNDER THIS AGREEMENT IS STRICTLY LIMITED TO NO MORE THAN THE AMOUNT PAID BY THE BUYER FOR THE GOODS.



**Force Majeure.** Seller shall not be responsible for any delay in the delivery of, or failure to deliver, Goods due to causes beyond Seller's reasonable control including, without limitation, acts of God, acts of war or terrorism, enemy actions, hostilities, strikes, labor difficulties, embargoes, non-delivery or late delivery of materials, parts and equipment or transportation delays not caused by the fault of Seller, delays caused by civil authorities, governmental regulations or orders, fire, lightening, natural disasters or any other cause beyond Seller's reasonable control. In the event of any such delay, performance will be postponed by such length of time as may be reasonably necessary to compensate for the delay.

**Installation.** If Buyer purchases any Goods that require installation, Buyer shall, at its expense, make all arrangements and connections necessary to install and operate the Goods. Buyer shall install the Goods in accordance with any Seller instructions and shall indemnify Seller against any and all damages, demands, suits, causes of action, claims and expenses (including actual attorneys' fees and costs) arising directly or indirectly out of Buyer's failure to properly install the Goods.

**Work By Others; Safety Devices.** Unless agreed to in writing by Seller, Seller has no responsibility for labor or work performed by Buyer or others, of any nature, relating to design, manufacture, fabrication, use, installation or provision of Goods. Buyer is solely responsible for furnishing, and requiring its employees and customers to use all safety devices, guards and safe operating procedures required by law and/or as set forth in manuals and instruction sheets furnished by Seller. Buyer is responsible for consulting all operator's manuals, ANSI or comparable safety standards, OSHA regulations and other sources of safety standards and regulations applicable to the use and operation of the Goods.

**Remedies.** Each of the rights and remedies of Seller under this Agreement is cumulative and in addition to any other or further remedies provided under this Agreement or at law or equity.

**Attorney's Fees.** In the event legal action is necessary to recover monies due from Buyer or to enforce any provision of this Agreement, Buyer shall be liable to Seller for all costs and expenses associated therewith, including Seller's actual attorneys' fees and costs.

**Governing Law/Venue.** This Agreement shall be construed and governed under the laws of the State of Wisconsin, without application of conflict of law principles. Each party agrees that all actions or proceedings arising out of or in connection with this Agreement shall be commenced, tried, and litigated only in the state courts sitting in Manitowoc County, Wisconsin or the U.S. Federal Court for the Eastern District of Wisconsin. Each party waives any right it may have to assert the doctrine of "forum non conveniens" or to object to venue to the extent that any proceeding is brought in accordance with this section. Each party consents to and waives any objection to the exercise of personal jurisdiction over it by courts described in this section. Each party waives to the fullest extent permitted by applicable law the right to a trial by jury.

**Summary of Return Policy.**

- 10 Day acceptance period from date of delivery. Damage claims and order discrepancies will not be accepted after this time.
- You must obtain a Baileigh issued RGA number PRIOR to returning any materials.
- Returned materials must be received at Baileigh in new condition and in original packaging.
- Altered items are not eligible for return.
- Buyer is responsible for all shipping charges.
- A 30% re-stocking fee applies to all returns.

Baileigh Industrial makes every effort to ensure that our posted specifications, images, pricing and product availability are as correct and timely as possible. We apologize for any discrepancies that may occur. Baileigh Industrial reserves the right to make any and all changes deemed necessary in the course of business including but not limited to pricing, product specifications, quantities, and product availability.

**For Customer Service & Technical Support:**

Please contact one of our knowledgeable Sales and Service team members at:  
(920) 684-4990 or e-mail us at [sales@baileigh.com](mailto:sales@baileigh.com)



## **INTRODUCTION**

*The quality and reliability of the components assembled on a Baileigh Industrial machine guarantee near perfect functioning, free from problems, even under the most demanding working conditions. However if a situation arises, refer to the manual first. If a solution cannot be found, contact the distributor where you purchased our product. Make sure you have the serial number and production year of the machine (stamped on the nameplate). For replacement parts refer to the assembly numbers on the parts list drawings.*

*Our technical staff will do their best to help you get your machine back in working order.*

### **In this manual you will find: (when applicable)**

- Safety procedures
- Correct installation guidelines
- Description of the functional parts of the machine
- Capacity charts
- Set-up and start-up instructions
- Machine operation
- Scheduled maintenance
- Parts lists

## **GENERAL NOTES**

After receiving your equipment remove the protective container. Do a complete visual inspection, and if damage is noted, **photograph it for insurance claims** and contact your carrier at once, requesting inspection. Also contact Baileigh Industrial and inform them of the unexpected occurrence. Temporarily suspend installation.

Take necessary precautions while loading / unloading or moving the machine to avoid any injuries.

Your machine is designed and manufactured to work smoothly and efficiently. Following proper maintenance instructions will help ensure this. Try and use original spare parts, whenever possible, and most importantly; **DO NOT** overload the machine or make any unauthorized modifications.



**Note:** This symbol refers to useful information throughout the manual.





## IMPORTANT

### PLEASE READ THIS OPERATORS MANUAL CAREFULLY

It contains important safety information, instructions, and necessary operating procedures. The continual observance of these procedures will help increase your production and extend the life of the equipment.

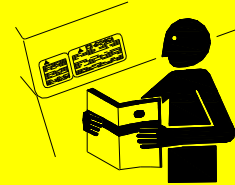

## SAFETY INSTRUCTIONS

### LEARN TO RECOGNIZE SAFETY INFORMATION

This is the safety alert symbol. When you see this symbol on your machine or in this manual, **BE ALERT TO THE POTENTIAL FOR PERSONAL INJURY!**



Follow recommended precautions and safe operating practices.

### UNDERSTAND SIGNAL WORDS

A signal word – **DANGER**, **WARNING**, or **CAUTION** is used with the safety alert symbol. **DANGER** identifies a hazard or unsafe practice that will result in severe **Injury or Death.**



Safety signs with signal word **DANGER** or **WARNING** are typically near specific hazards.



General precautions are listed on **CAUTION** safety signs. **CAUTION** also calls attention to safety messages in this manual.





**SAVE THESE INSTRUCTIONS.**  
**Refer to them often and use them to instruct others.**



**PROTECT EYES**

Wear safety glasses or suitable eye protection when working on or around machinery.

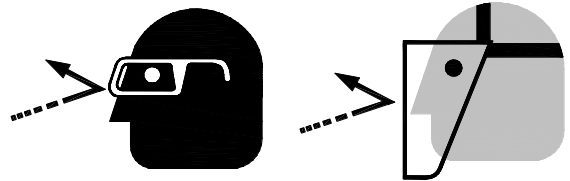

**PROTECT AGAINST NOISE**

Prolonged exposure to loud noise can cause impairment or loss of hearing. Wear suitable hearing protective devices such as ear muffs or earplugs to protect against objectionable or uncomfortable loud noises.

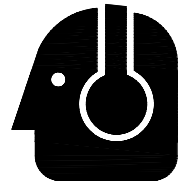

**HYDRAULIC HOSE FAILURE**

Exercise **CAUTION** around hydraulic hoses in case of a hose or fitting failure.

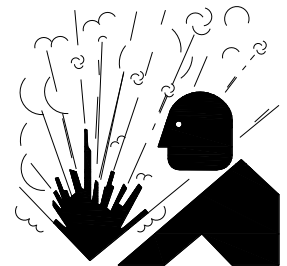

**BEWARE OF CRUSH HAZARD**

**NEVER** place your hands, fingers, or any part of your body in the die area of this machine. Keep hands and fingers away from the ram and tooling when the machine is in operation.

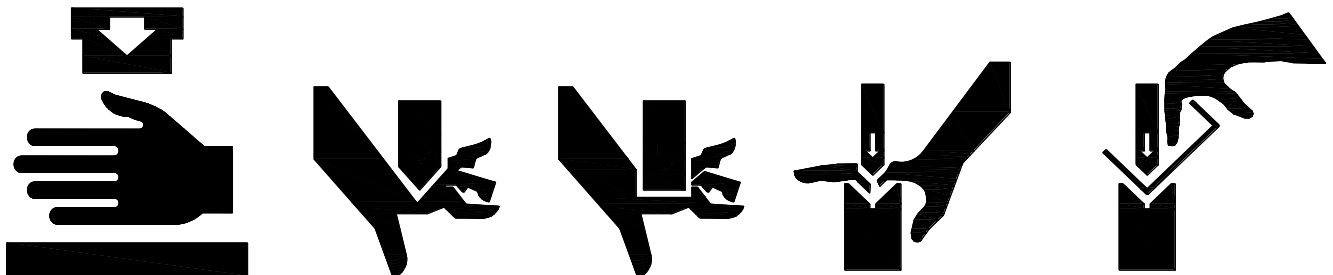





### HIGH VOLTAGE

**USE CAUTION IN HIGH VOLTAGE AREAS. DO NOT** assume the power to be off.  
**FOLLOW PROPER LOCKOUT PROCEDURES.**

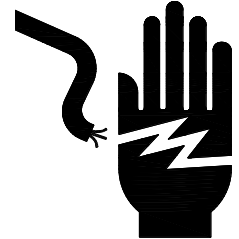

### EMERGENCY STOP BUTTON

In the event of incorrect operation or dangerous conditions, the machine can be stopped immediately by pressing the **E-STOP** button. Twist the emergency stop button clockwise (cw) to reset. Note: Resetting the E-Stop will not start the machine.



## SAFETY PRECAUTIONS



Metal working can be dangerous if safe and proper operating procedures are not followed. As with all machinery, there are certain hazards involved with the operation of the product. Using the machine with respect and caution will considerably lessen the possibility of personal injury. However, if normal safety precautions are overlooked or ignored, personal injury to the operator may result.

Safety equipment such as guards, hold-downs, safety glasses, dust masks and hearing protection can reduce your potential for injury. But even the best guard won't make up for poor judgment, carelessness or inattention. **Always use common sense** and exercise **caution** in the workshop. If a procedure feels dangerous, don't try it.

**REMEMBER: Your personal safety is your responsibility.**



**WARNING: FAILURE TO FOLLOW THESE RULES MAY RESULT IN SERIOUS PERSONAL INJURY**

1. **Only trained and qualified personnel can operate this machine.**
2. **Make sure guards are in place and in proper working order before operating machinery.**
3. **Remove any adjusting tools.** Before operating the machine, make sure any adjusting tools have been removed.



4. **Keep work area clean.** Cluttered areas invite injuries.
5. **Overloading machine.** By overloading the machine you may cause injury from flying parts. **DO NOT** exceed the specified machine capacities.
6. **Dressing material edges.** Always chamfer and deburr all sharp edges.
7. **Do not force tool.** Your machine will do a better and safer job if used as intended. **DO NOT** use inappropriate attachments in an attempt to exceed the machines rated capacity.
8. **Use the right tool for the job.** **DO NOT** attempt to force a small tool or attachment to do the work of a large industrial tool. **DO NOT** use a tool for a purpose for which it was not intended.
9. **Dress appropriate.** **DO NOT** wear loose fitting clothing or jewelry as they can be caught in moving machine parts. Protective clothing and steel toe shoes are recommended when using machinery. Wear a restrictive hair covering to contain long hair.
10. **Use eye and ear protection.** Always wear ISO approved impact safety goggles. Wear a full-face shield if you are producing metal filings.
11. **Do not overreach.** Maintain proper footing and balance at all times. **DO NOT** reach over or across a running machine.
12. **Stay alert.** Watch what you are doing and use common sense. **DO NOT** operate any tool or machine when you are tired.
13. **Check for damaged parts.** Before using any tool or machine, carefully check any part that appears damaged. Check for alignment and binding of moving parts that may affect proper machine operation.
14. **Observe work area conditions.** **DO NOT** use machines or power tools in damp or wet locations. Do not expose to rain. Keep work area well lighted. **DO NOT** use electrically powered tools in the presence of flammable gases or liquids.
15. **Keep children away.** Children must never be allowed in the work area. **DO NOT** let them handle machines, tools, or extension cords.
16. **Store idle equipment.** When not in use, tools must be stored in a dry location to inhibit rust. Always lock up tools and keep them out of reach of children.
17. **DO NOT operate machine if under the influence of alcohol or drugs.** Read warning labels on prescriptions. If there is any doubt, **DO NOT** operate the machine.
18. **DO NOT** touch live electrical components or parts.
19. **Turn off** power before checking, cleaning, or replacing any parts.
20. Be sure **all** equipment is properly installed and grounded according to national, state, and local codes.
21. Inspect power and control cables periodically. Replace if damaged or bare wires are exposed. **Bare wiring can kill!**



22. **DO NOT** bypass or defeat any safety interlock systems.

23. Keep visitors a safe distance from the work area.

 **IMPORTANT:** Maximum pressing force can be exerted for a short time only. Do not use maximum force when the ram is extended further than 3/4 of its length. This can damage the piston rod.



Maximum force with long stroke

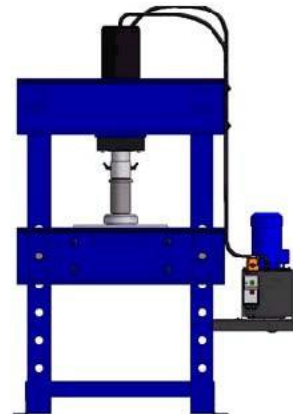

Maximum force with short stroke



**Note:** Not observing the maximum working period can result in overheating the hydraulic oil and heating up the hydraulic unit. The machine can get damaged and the operator may suffer burns.



## TECHNICAL SPECIFICATIONS

Model	HSP-110M-HD	HSP-110M-1500-HD
Press Power	110tons (100metric tons)	
Maximum pressure	3814psi (263bar)	
Stroke	11.8" (300mm)	
Piston diameter	Ø8.66"x6.3"mm (Ø220x160mm)	
Advance Speed	.31"/sec) (8mm/sec)	
Working Speed	.20"/sec) (5mm/sec)	
Return Speed	.39"/sec) (10mm/sec)	
Table Width	42.12" (1070mm)	61.81" (1570mm)
Power	220V, 3ph, 60hz	
Motor	7.5hp (5.5kw) 220V / 3ph / 60hz / 25A	
Oil Capacity	25.5gal (97L)	
Oil Type	HL46	
Dimensions W x D x H	80.7" x 39.4" x 86.6" (2050 x 1000 x 2200mm)	98.4" x 39.4" x 86.6" (2500 x 1000 x 2200mm)
Weight	3307lbs (1500kg)	3748lbs (1700kg)

## TECHNICAL SUPPORT

Our technical support department can be reached at 920.684.4990, and asking for the support desk for purchased machines. Tech Support handles questions on machine setup, schematics, warranty issues, and individual parts needs: (other than die sets and blades).

For specific application needs or future machine purchases contact the Sales Department at: [sales@baileigh.com](mailto:sales@baileigh.com), Phone: 920.684.4990, or Fax: 920.684.3944.



**Note:** The photos and illustrations used in this manual are representative only and may not depict the actual color, labeling or accessories and may be intended to illustrate technique only.



**Note:** The specifications and dimensions presented here are subject to change without prior notice due to improvements of our products.



## UNPACKING AND CHECKING CONTENTS

Your Baileigh machine is shipped complete in one crate. Separate all parts from the packing material and check each item carefully. Make certain all items are accounted for before discarding any packing material.

**⚠ WARNING: SUFFOCATION HAZARD!** Immediately discard any plastic bags and packing materials to eliminate choking and suffocation hazards to children and animals.  
If any parts are missing, do not plug in the power cable, or turn the power switch on until the missing parts are obtained and installed correctly.

### Cleaning

**⚠ WARNING: DO NOT USE** gasoline or other petroleum products to clean the machine. They have low flash points and can explode or cause fire.

**⚠ CAUTION:** When using cleaning solvents work in a well-ventilated area. Many cleaning solvents are toxic if inhaled.

Your machine may be shipped with a rustproof waxy coating and/or grease on the exposed unpainted metal surfaces. Fully and completely remove this protective coating using a degreaser or solvent cleaner. Moving items will need to be moved along their travel path to allow for cleaning the entire surface. For a more thorough cleaning, some parts will occasionally have to be removed. **DO NOT USE** acetone or brake cleaner as they may damage painted surfaces.

Follow manufacturer's label instructions when using any type of cleaning product. After cleaning, wipe unpainted metal surfaces with a light coating of quality oil or grease for protection.



**Important:** This waxy coating is **NOT** a lubricant and will cause the machine to stick and lose performance as the coating continues to dry.





## TRANSPORTING AND LIFTING



**IMPORTANT:** Lifting and carrying operations should be carried out by skilled workers, such as a truck operator, crane operator, etc. If a crane is used to lift the machine, attach the lifting chain carefully, making sure the machine is well balanced.

### Follow these guidelines when lifting with truck or trolley:

- The lift truck must be able to lift at least 1.5 – 2 times the machines gross weight.
- Make sure the machine is balanced. While transporting, avoid rough or jerky motion, and maintain a safe clearance zone around the transport area.
- Use a fork lift with sufficient lifting capacity and forks that are long enough to reach the complete width of the machine.
- Remove the securing bolts that attach the machine to the pallet.
- Approaching the machine from the side, lift the machine on the frame taking care that there are no cables or pipes in the area of the forks.
- Move the machine to the required position and lower gently to the floor.
- Level the machine so that all the supporting feet are taking the weight of the machine and no rocking is taking place.

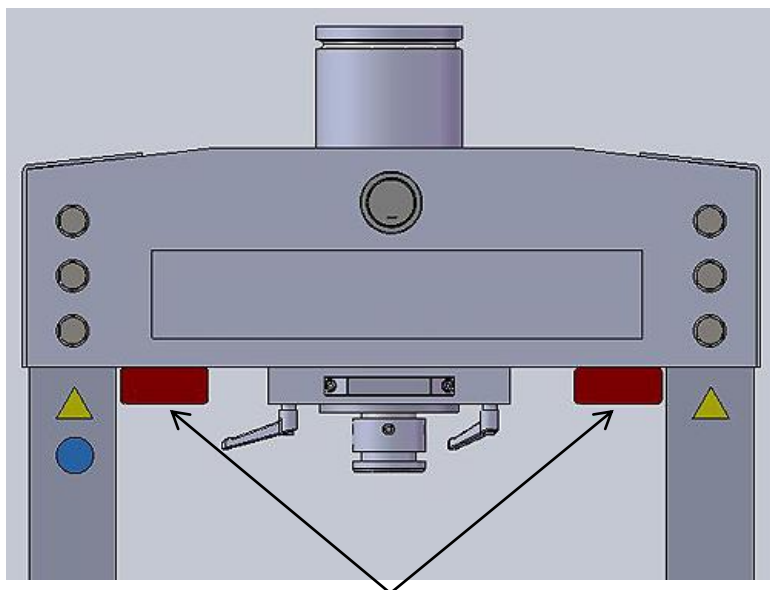

Lift with Forks Here

### Follow these guidelines when lifting crane or hoist:

- Always lift and carry the machine with the lifting holes provided at the top of the machine.
- Use lift equipment such as straps, chains, capable of lifting 1.5 to 2 times the weight of the machine.
- Take proper precautions for handling and lifting.

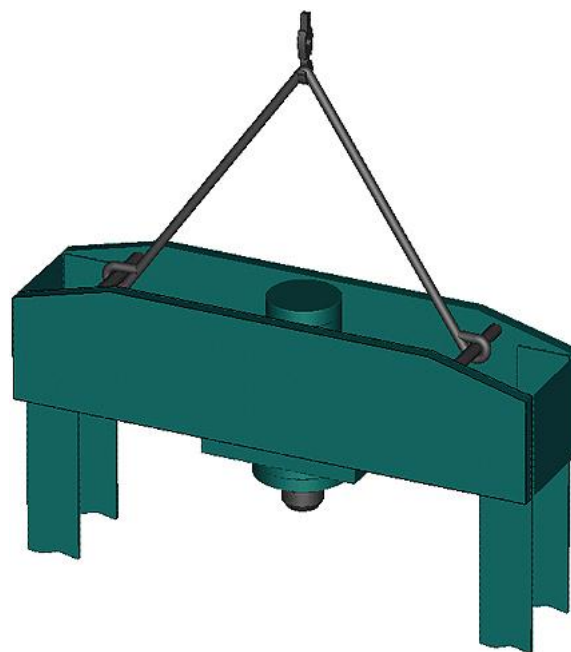





- Check if the load is properly balanced by lifting it an inch or two.
- Lift the machine, avoiding sudden accelerations or quick changes of direction.
- Locate the machine where it is to be installed, and lower slowly until it touches the floor.

## **INSTALLATION**

### **IMPORTANT:**

Consider the following when looking for a suitable location to place the machine:

- Overall weight of the machine.
- Weight of material being processed.
- Sizes of material to be processed through the machine.
- Space needed for auxiliary stands, work tables, or other machinery.
- Clearance from walls and other obstacles.
- Maintain an adequate working area around the machine for safety.
- Have the work area well illuminated with proper lighting.
- Keep the floor free of oil and make sure it is not slippery.
- Remove scrap and waste materials regularly, and make sure the work area is free from obstructing objects.
- If long lengths of material are to be fed into the machine, make sure that they will not extend into any aisles.
- **LEVELING:** The machine should be sited on a level, concrete floor. Provisions for securing it should be in position prior to placing the machine. The accuracy of any machine depends on the precise placement of it to the mounting surface.
- **FLOOR:** This tool distributes a large amount of weight over a small area. Make certain that the floor is capable of supporting the weight of the machine, work stock, and the operator. The floor should also be a level surface. If the unit wobbles or rocks once in place, be sure to eliminate by using shims.
- **WORKING CLEARANCES:** Take into consideration the size of the material to be processed. Make sure that you allow enough space for you to operate the machine freely.
- **POWER SUPPLY PLACEMENT:** The power supply should be located close enough to the machine so that the power cord is not in an area where it would cause a tripping hazard. Be sure to observe all electrical codes if installing new circuits and/or outlets.





## Anchoring the Machine

**⚠ WARNING:** Before operating the press, make sure it is firmly anchored to the floor. If it tips over on you, it could cause severe injury or death.

- Once positioned, anchor the machine to the floor, as shown in the diagram, using bolts and expansion plugs or sunken tie rods that connect through holes in the base of the stand.
- Provide adequate clearance for the equipment in an environment that is clean, non-flammable, non-corrosive, and dust free.

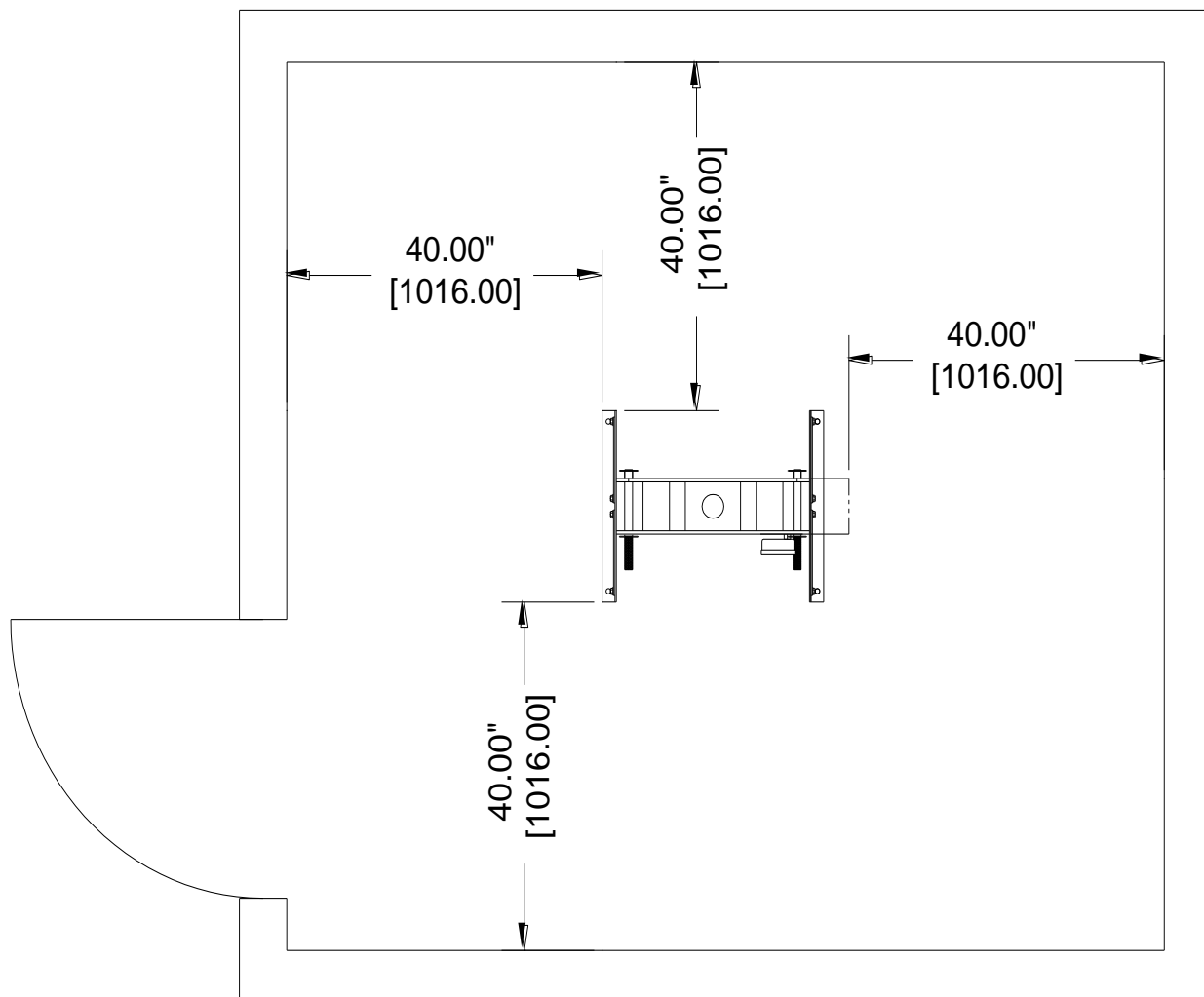

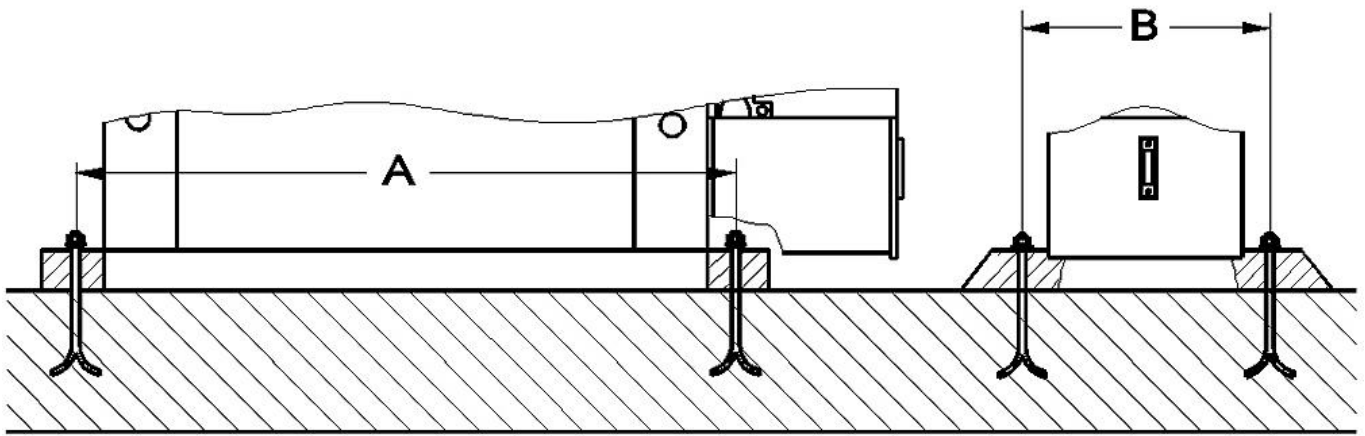

MODEL	A	B
HSP-110M-HD	57.08" (1450mm)	25.98" (660mm)
HSP-110M-1500-HD	76.77" (1950mm)	25.98" (660mm)



## DIMENSIONS

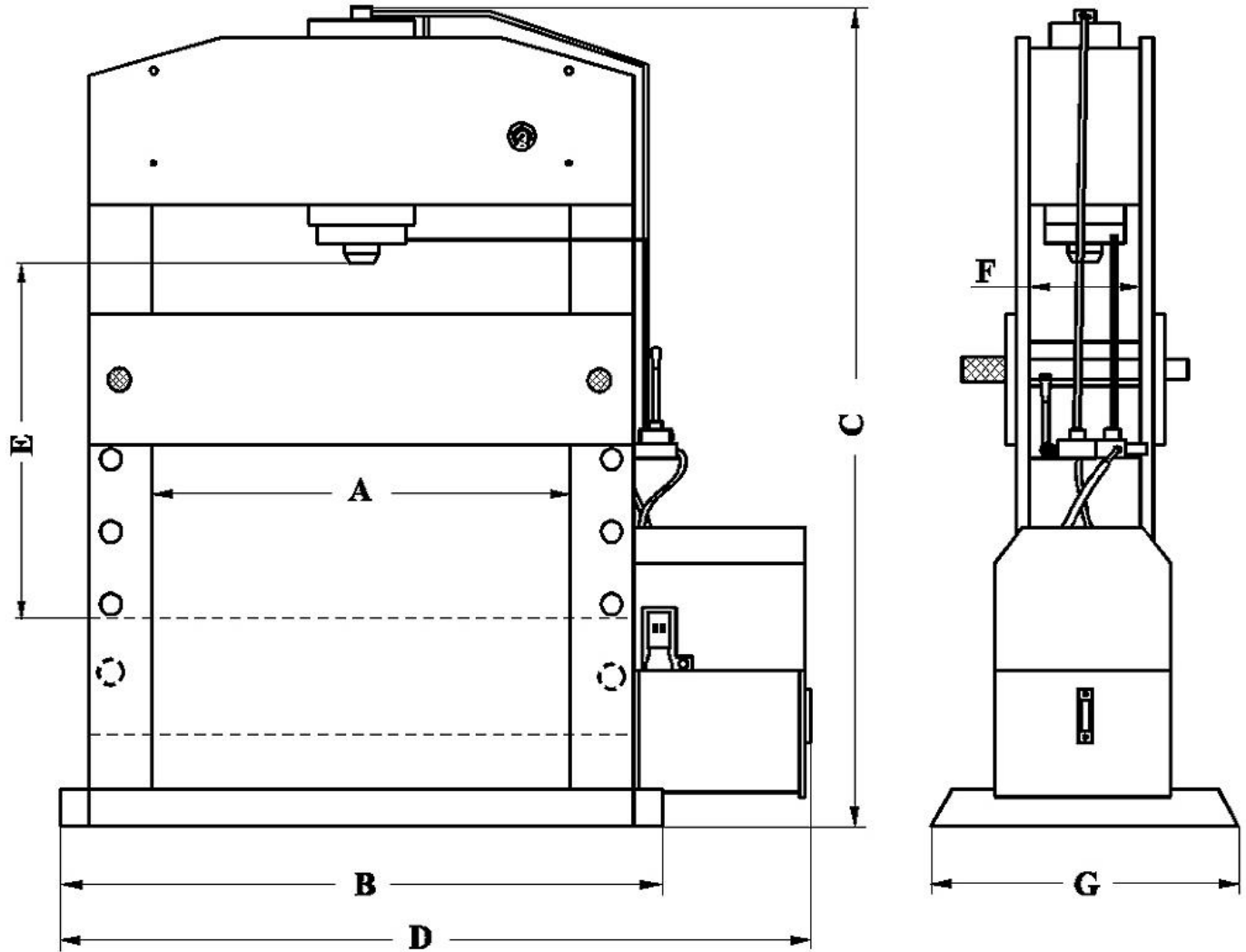

Model	A	B	C	D	E	F	G
HSP-110M-HD	42.12" (1070mm)	64.17" (1630mm)	95.67" (2430mm)	85.03" (2160mm)	32.28" (820mm)	12.40" (315mm)	39.37" (1000mm)
HSP-110M-1500-HD	61.81" (1570mm)	83.86" (2130mm)	95.67" (2430mm)	104.72" (2660mm)	32.28" (820mm)	12.40" (315mm)	39.37" (1000mm)



## GETTING TO KNOW YOUR MACHINE





Item	Description
A	Main Frame; Supports the entire machine components and work material.
B	Support Pins; Supports the work table at the desired work height.
C	Heal Blocks / V-Blocks; used to support the material during the pressing operation.
D	Work Table Lift Chain; Used to lift and lower the work table using the cylinder to provide the lifting and lowering force.
E	Serrated Saddle; presses against the work material.
F	Press Cylinder; Provides the force to complete the press operation.
G	Pressure Gauge; displays the current pressure during operation.
H	Hydraulic Operating Lever; Push or pull to raise or lower the ram.
I	Hydraulic Pump Motor (inside cabinet); Runs the hydraulic pump to create the oil flow and pressure used during operation.
J	Hydraulic Tank; Hold the hydraulic oil and support the hydraulic controls.
K	On / Off Switch. Starts and stops the electric pump motor.
L	Work Table; Moveable table to raise or lower to support the material to be pressed.



## ASSEMBLY AND SET UP



**WARNING:** For your own safety, **DO NOT** connect the machine to the power source until the machine is completely assembled and you read and understand the entire instruction manual.



**Note:** The hydraulic unit weights about 200lbs (95kg). For placing the unit in the correct position, use and assistant or safe lifting equipment to lift the unit.

During shipping, the hydraulic unit is mounted in the inside of the frame.

To place the unit in working position:

1. Remove the strapping and packing materials holding the hydraulic tank assembly on the table and to the inside of the frame.
2. Remove and retain the bolts, washers and nuts from the mounting plate on the right side of the press.
3. Position the hydraulic assembly on the right side of the press.
4. Align the bolt holes and install and tighten the bolts, washers and nuts removed from the mounting plate.
5. Route the hydraulic hoses to the hydraulic fitting and matching the number labels (1 to 1 and 2 to 2), one at a time, remove the plugs and install the hoses to the fittings. Tighten securely, however do not over tighten and distort the swivel fitting collar.
6. Route the hydraulic hoses to the top of the hydraulic cylinder and matching the number labels (1 to 1 and 2 to 2), one at a time, remove the plugs and install the hoses to the fittings. Tighten securely, however do not over tighten and distort the swivel fitting collar.
7. Fill the tank with hydraulic oil. The press is shipped without oil. Before starting up, the tank needs to be filled with hydraulic oil #46 SHELL BRAND or an equivalent with similar specifications.
8. Remove the filler plug on top of the hydraulic tank.
9. Fill the tank with approximately 26.5gal. (100L) of hydraulic oil.
10. Replace the filler plug.



**IMPORTANT: NEVER** run the motor with a low oil level. This will damage the hydraulic unit.

11. Locate, remove and retain the three screws that will secure the motor cover onto the hydraulic tank and the side of the frame.



12. Place the cover over the motor and hydraulics so that the cutout provides access to the operating controls.
13. Secure in place using the three screws removed earlier





## ELECTRICAL

**⚠ WARNING:** Baileigh Industrial is not responsible for any damage caused by wiring up to an alternative 3-phase power source other than direct 3-phase. If you are using an alternate power source, consult a certified electrician or contact Baileigh Industrial prior to energizing the machine.

**⚠ CAUTION:** HAVE ELECTRICAL UTILITIES CONNECTED TO MACHINE BY A CERTIFIED ELECTRICIAN!  
Check if the available power supply is the same as listed on the machine nameplate.

**⚠ WARNING:** Make sure the grounding wire (green) is properly connected to avoid electric shock. DO NOT switch the position of the green grounding wire if any electrical plug wires are switched during hookup.

### Motor Specifications

Your tool is wired for 220 volt, 60Hz alternating current. Before connecting the tool to the power source, make sure the machine is cut off from power source.

### Considerations

- Observe local electrical codes when connecting the machine.
- The circuit should be protected with a time delay fuse or circuit breaker with a amperage rating slightly higher than the full load current of machine.
- A separate electrical circuit should be used for your tools. Before connecting the motor to the power line, make sure the switch is in the "OFF" position and be sure that the electric current is of the same characteristics as indicated on the tool.
- All line connections should make good contact. Running on low voltage will damage the motor.
- In the event of a malfunction or breakdown, grounding provides a path of least resistance for electric current to reduce the risk of electric shock. This tool is equipped with an electric cord having an equipment-grounding conductor and a grounding plug. The plug must be plugged into a matching outlet that is properly installed and grounded in accordance with all local codes and ordinances.



**⚠ WARNING:** Make certain any receptacle in question is properly grounded. If you are not sure, have a qualified electrician check the receptacle.

- Improper connection of the equipment-grounding conductor can result in risk of electric shock. The conductor with insulation having an outer surface that is green with or without yellow stripes is the equipment-grounding conductor. If repair or replacement of the electric cord or plug is necessary, do not connect the equipment-grounding conductor to a live terminal.
- Check with a qualified electrician or service personnel if the grounding instructions are not completely understood, or if in doubt as to whether the tool is properly grounded.
- Repair or replace damaged or worn cord immediately.

**Power cord connection:**

1. Unwrap the power cord and route the cord away from the machine toward the power supply.
  - a. Route the power cord so that it will NOT become entangled in the machine in any way.
  - b. Route the cord to the power supply in a way that does NOT create a trip hazard.
2. Connect the power cord to the power supply and check that the power cord has not been damaged during installation.
3. Once hooked up, turn on the power supply and start the machine.
4. Check that the motor is running in the correct direction.
5. If not, cut the power to the machine. Swap the position of any two of the three power wires; but DO NOT change the position of the green grounding wire!

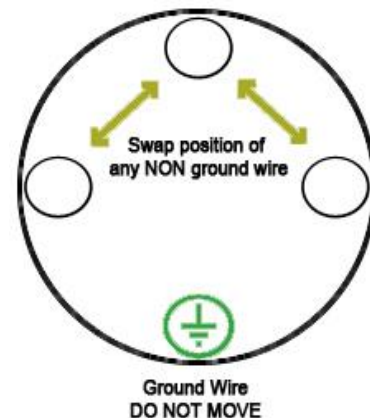



## OPERATION PREPLANNING

This is a general discussion on press operation and is not intended to be an exact step-by-step procedure. This is intended to create a broad thought process to be considered prior to using the press to stimulate the operator into thinking about as many possible scenarios that could cause injury or material damage. The operator should then take all steps they can think of to prevent or protect against such possible scenarios

**The following is a listing of some of the most common procedures the operator shall take into consideration and employ. The specific application will require the operator to address any items not covered here.**

- Provide a container or applicable padding under the press to protect the part when it drops.
- Positions the heel plates to support the workpiece, and aligns the press pin or tooling on the part to be pressed.
- Preload the workpiece prior to proceeding with the full pressing operation.
- View the setup from various angles, and verify that the ram remains aligned with and centered with the workpiece and the bed.
- Relieves the hydraulic pressure and allows the ram to return to the retracted position.



**WARNING:** Failure to center the piece part on the blocks and the ram to the piece part may cause serious injury.  
Never compress springs or objects that when compressed, could shatter, or explode out of the press causing serious injury.

## Workpiece Considerations

Before using this hydraulic press, you must inspect the workpiece. This is not a comprehensive list but rather a list of common issues. It is up to you to address any additional special items required to prepare your workpiece for press operations. Not addressing the items below can lead to galled, seized, or broken housings. Ignoring any of the items listed can lead to a workpiece or tooling being ejected from the press, which could cause severe injury or death.

- **Material Strength:** Make sure that the workpiece material is designed to withstand the intended force the press will apply.
- **Material Cleanliness:** Make sure that the workpiece is clean and that all burrs, grit, rust, or damage is removed from the pressing path. Light oiling on the components may prevent galling or seizing.



- **Pressing Path and Sequence:** Make sure that the direction of the component to be pressed on or off is correct and that the correct size of sleeve or arbor plate is used for support.
- **Fasteners and Retainers:** Make sure that all retaining rings, pins, or fasteners are removed, and no hidden secondary retainers are present.
- **Hidden Objects:** Some components house one or more pieces such as springs, retaining rings, or spacers. Make sure that the part to be dismantled with the press has the applicable caging system to catch hidden items. Should the workpiece slip or open up when the retaining ring is removed and the hydraulic pressure is relieved.
- **Special Fits:** Make sure that interference fits are correct before pressing a part on, and make sure that the applicable parts have been heated or chilled to the correct temperatures to avoid galling and seizing. Be aware, that not all parts were designed to be pressed off. If in doubt, refer to the OEM of the part you are working on.

### General Information

The Hydraulic Workshop Press is designed for:

- Bending and straightening of beams, profiles, pivots, shaft etc.
- (dis)assembly of bearings, bushings or pivots
- stamping, punching, forming of wide range of materials

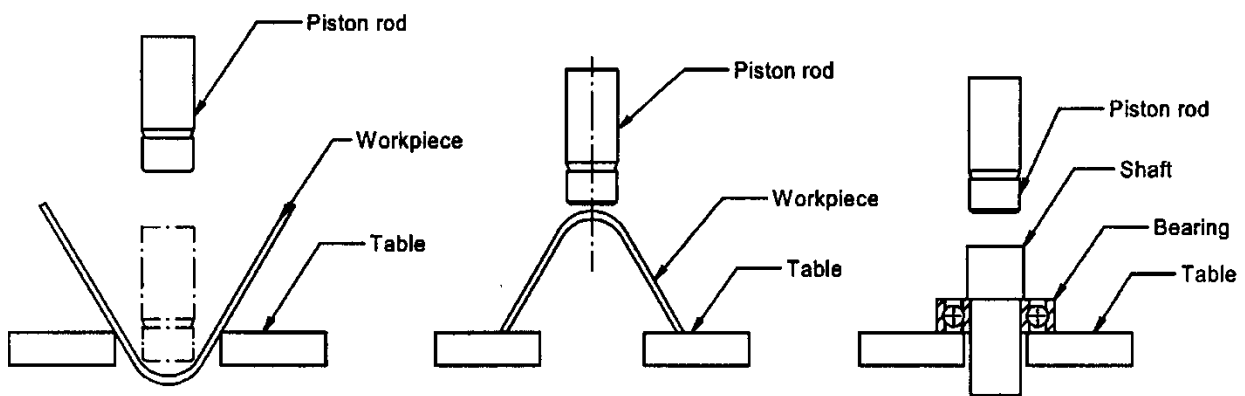

Typical use of press

This machine can be used in repair shops, workshops, etc. To enable more options, the machine can be equipped with special tools as V-block or an inner table.



## PRESS FUNCTIONS

### On /Off Switch

The On / Off switch is located on the front of the electrical panel on top of the hydraulic tank.

- Turn the switch to the ON position to supply power to the electrical controls. The indicator light on the electrical box will light up as long as the switch is ON.
- Turn the switch to the OFF position to remove power and stop the motor.

### Direction Control Valve

The direction control valve is located on the right side of the press frame.

The valve has 4 lever (A) positions labeled Fast 2, Slow 1, Stop 0, and Back R.

- Stop 0 position: When the lever has not been operated, the valve will always return to this position. There is no movement of the piston.
- Back R position: When the lever is pushed inwards, the piston will raise. As long as the valve is operated, the piston will move until it is fully retracted. When the lever is released, it will return to the stop 0 position and the piston will stop and stay in the current position.
- Slow 1 position: When the lever is pulled outwards to the first position, the piston will extend at the working speed of  $.20''/\text{sec}$  (5mm/sec). As long as the valve is held in this position, the piston will move downward. When the lever is released, the piston will stop and stay in this position. This position will develop full pressure and should be used during the actual pressing process.
- Fast 2 position: When the lever is pulled outwards to the second position, the piston will extend at the advancing speed of  $.31''/\text{sec}$  (8mm/sec). As long as the valve is held in this position, the piston will move. When the lever is released, the piston will stop and stay in this position. This position is for advancing the ram to the material to be pressed. When the ram is within  $.75''$  (19-20mm) the lever should be moved back to the Slow 1 position to complete the operation.

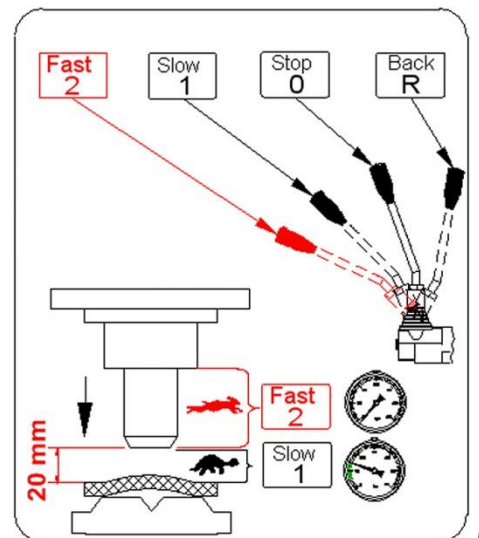





### Pressure Gauge

The pressure gauge is located in the head of the press. The gauge gives the pressure in PSI and BAR. The maximum pressure for this press is 3814psi. (263 bar). If this maximum pressure is reached, also the maximum capacity of the press is reached.

### Pressure Regulation Valve



**CAUTION: NEVER EXCEED THE MAXIMUM PRESSURE SETTING!**

The pressure regulation valve is located on the hydraulic control valve. With this valve the maximum pressure, referring to the maximum press capacity, can be changed. Turning the adjustment clockwise will increase the pressure, turning the adjustment counter clockwise will decrease the pressure. Adjusting the pressure to meet the material can be very beneficial in completing the pressing operation while reducing the change to damage the piece part. Working at reduced pressure when available will also reduce the stress on the press and the hydraulic system. Use the chart next to the pressure gauge to determine the pressing force at the pressures listed.

### Pressure Adjusting

1. Start the hydraulic unit.
2. Make sure the piston is in rest position (no force applied).
3. Set the table height in the top position.
4. Place the heel blocks on the table.
5. Remove the acorn nut.
6. Loosen the jam nut (A) and turn the adjustment screw counter clockwise 1/2 to 1 full turn to reduce the pressure. Do not overturn and remove the screw!
7. Extend the ram down until it reaches the heel blocks. Hold the lever in the down position and read the pressure on the pressure gauge.
8. Slowly turn the adjusting screw in or out as desired to set the desired pressure. **NEVER EXCEED THE MAXIMUM PRESSURE SETTING!**





9. When the pressure is set, hold the adjustment screw in position and lightly tighten the jam nut (A) to hold the screw and prevent inadvertent pressure changes.
10. Install the acorn nut.

### Air Purge

When starting up for the first time or when maintenance on the hydraulic system has been performed, the hydraulic system needs to be purged.

1. Make sure there is no work piece on the table.
2. Start the hydraulic unit.
3. Move the pump selection valve rearward to the electric pump position.
4. If not already fully retracted, using the directional control valve to fully retract the ram.
5. Extend the ram to the fully lowered position.
6. Now fully retract the ram.
7. Repeat this complete cycle at least 6 times to be sure all air is out of the system.



**IMPORTANT:** Air in the hydraulic system can cause unexpected piston movement and poor overall press operation.

### Cylinder Positioning

This press is equipped with a movable cylinder which makes it possible to position the cylinder correctly aligned with the work piece.

To move the cylinder:

1. Loosen the lever (A), 1 to 2 turn counter clockwise.
2. Move the complete cylinder to the left or right.
3. Tighten the lever again when the cylinder is in the correct position over the workpiece. Hand tightening is enough, do not use any wrench or exaggerated force to tighten the lever.







## Table Adjustment

**⚠ IMPORTANT:** NEVER lift or lower the table with tooling or material or pressure from the ram on the table. This will damage the machine voiding the warranty.

Lifting the table is performed using the lifting chain attached from the ram to the table.

1. If lifting the table; start with the piston extended to full stroke. If lowering the table; start with the piston extended about 1" (25mm).
2. Install the eye bolt into the end of the ram and hand tighten.
3. Feed the chain through the eye bolt and around the two center cross bars. Remove as much slack form the chains as possible and link the hook onto the chain.
4. Raise the piston enough to lift the table to remove the table support pins.
5. Remove the retaining pins from the back of the support pins.
6. If lowering the table, install the support pins the desired holes. If raising the table, raise the table high enough to expose the holes below the table and then install the support pins.
7. When the support pins are in the desired holes, install the retaining pins on the back of the support pins.



**Note:** The table always needs to be higher than the hole you want to place the support pin. It may be necessary to reach the desired table position in more than one step.

8. The support pin is installed correctly when the collar is tight to the table and the table slot rests fully on the pin.
9. Lower the table until it rests on both support pins.
10. Remove the lifting chain out of the working area.



**Using the Machine:**

Incorrect

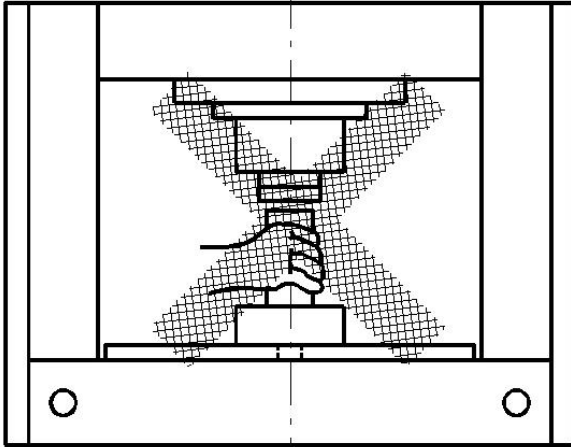

Correct

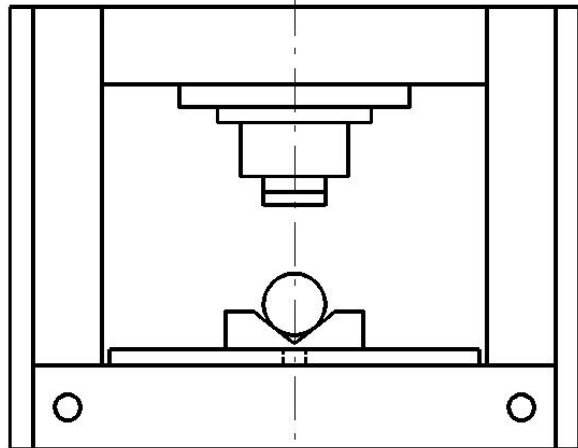
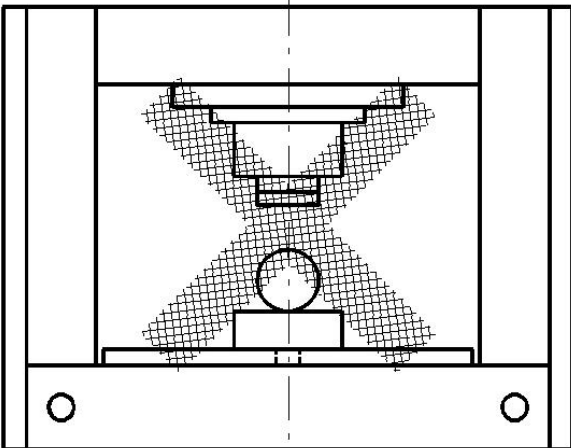
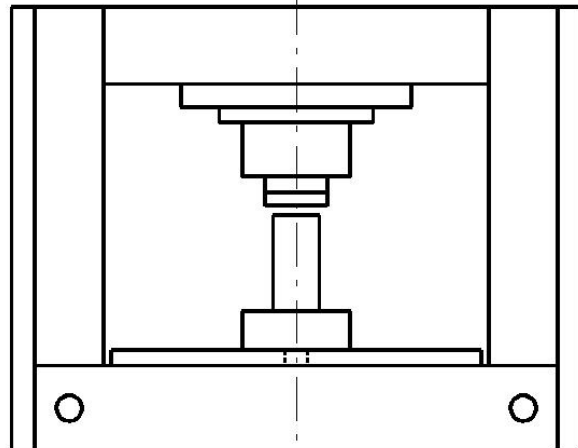
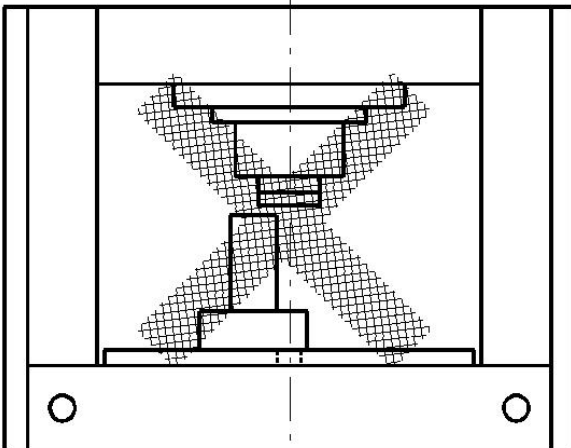
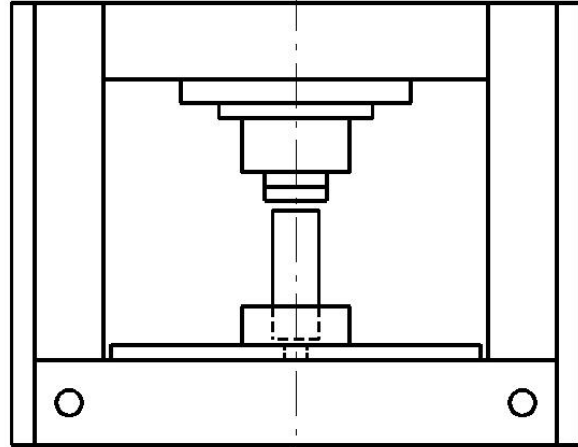

Incorrect

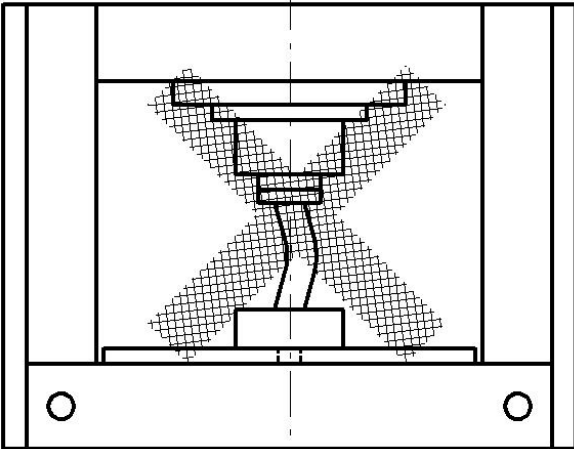

Correct

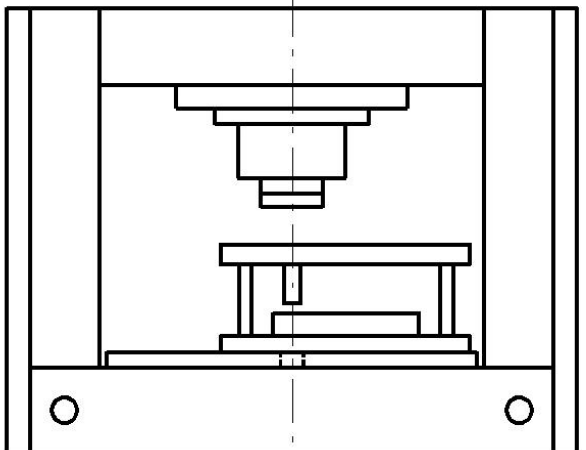
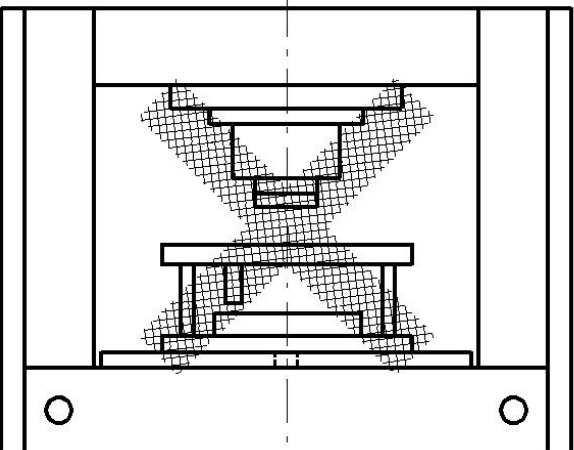
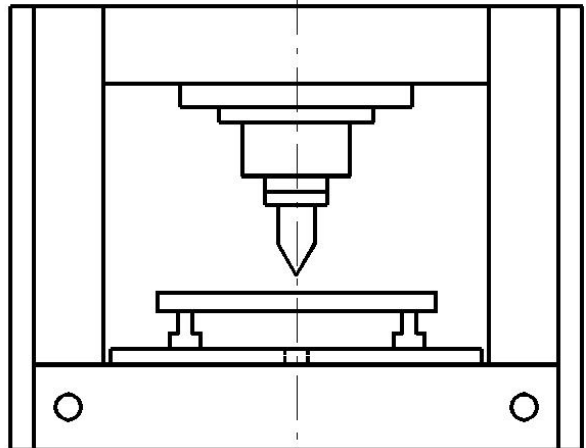
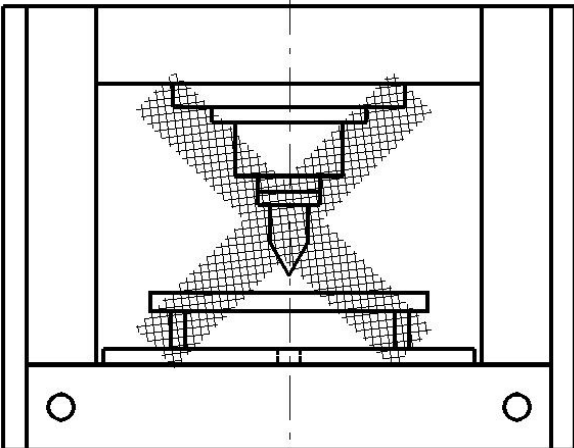
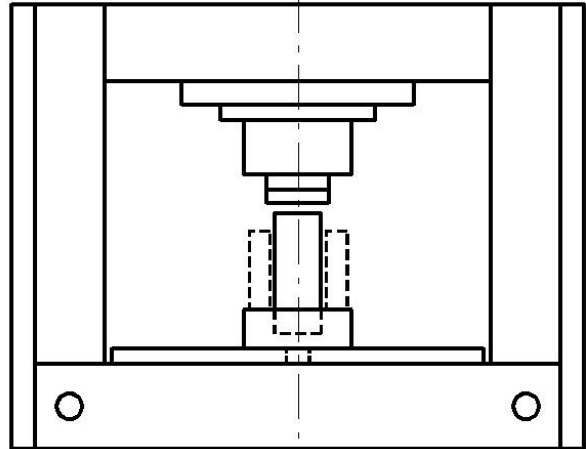



## OPERATION

 **CAUTION:** Always wear proper eye protection with side shields, safety footwear, and leather gloves to protect from burrs and sharp edges.

1. Place the work piece on the table so that it is aligned with the piston rod. If this is not possible, reposition the cylinder to achieve the best alignment.

 **WARNING:** Failure to center the piece part on the blocks and the ram to the piece part may cause serious injury. Never compress springs or objects that when compressed, could shatter, or explode out of the press causing serious injury.

2. Take care when performing operation on elements that are likely to fly off, break (especially casting element and hardened elements) or bounce up as a result of the applied force. In this case, a cover must be installed around the work piece or the operator should stand at a safe distance.
3. After correct placement of the work piece, pressing force can be applied using the directional valve as described in the previous section.



**Note:** *Upwards movement of the piston is only allowed for adjustment of the table, or returning the piston to its start position. Any other use of the return stroke (e.g. stretching) can result in broken parts and de-function of the press.*

When pressing operations are finished:

4. Return the piston back to its upper position.
5. Position the cylinder back it the center of the machine.
6. Turn of the hydraulic unit.
7. Clean up the machine and working area.



## **UNDERSTANDING SPRINGBACK**

Springback, also known as elastic recovery, is the result of the metal wanting to return to its original shape after undergoing compression and stretch. After the bending leaf is removed from the metal and the load is released, the piece part relaxes, forcing the bent portion of the metal to return slightly to its original shape. The key to obtaining the correct bend angle is to over bend the metal a little and allow it to spring back to the desired angle. All metals exhibit a certain amount of spring back.

## **MATERIAL SELECTION**

**⚠ CAUTION:** It must be determined by the customer that materials being processed through the machine are **NOT** potentially hazardous to operator or personnel working nearby.

When selecting materials keep these instructions in mind:

- Material must be clean and dry. (without oil)
- Material should have a smooth surface so it processes easily.
- Dimensional properties of material must be consistent and not exceed the machine capacity values.
- Chemical structure of material must be consistent.
- Buy certificated steel from the same vendor when possible.



## LUBRICATION AND MAINTENANCE

 **WARNING:** Make sure the electrical disconnect is OFF before working on the machine.  
Maintenance should be performed on a regular basis by qualified personnel.  
Always follow proper safety precautions when working on or around any machinery.



*Note: Proper maintenance can increase the life expectancy of your machine.*

### Daily Maintenance

- Check daily for any unsafe conditions and fix immediately. In case of leakages, damaged parts or bare electric cables; do not use the machine before it is repaired.
- Check that all nuts and bolts are properly tightened.
- Lubricate threaded components pivot points and sliding devices.
- Check hydraulic hoses and fittings for leakage.
- Keep area around machine clear of debris.
- Clean the outside of the press with a clean, soft, and dry cloth.
- When not in use, keep the press dry and covered. Keep the ram and piston fully retracted to prevent rust or corrosion.
- If press efficiency drops, purge air from the hydraulic system.

**DO NOT** allow lubricant on the frame bed or the heel blocks. Wipe off immediately.

### Weekly Maintenance

- On a weekly basis clean the machine and the area around it.
- Apply rust inhibitive lubricant to all non-painted surfaces.
- Check oil level of the hydraulic unit.
- Check electrical connections.
- Check lifting chains.

### 6 Month Maintenance

- Inspect all hydraulic fittings and hoses and tighten any loose connections.



### **Two Year Maintenance**

- Replace the hydraulic oil of the unit.

### **Changing the Hydraulic Oil**

The hydraulic oil is the primary medium for transmitting pressure and also must lubricate the running parts of the pump.

Replace the hydraulic oil at least once a year.

1. Remove top cover and motor assembly and move aside enough to access the inside of the tank.
2. Using a suitable container and a siphon pump, drain the oil from the tank.
3. Clean the inside of the tank.
4. Remove and clean the suction filter.
5. Install the filter.
6. Check the drained oil. If there are metal particles visible, or if the oil has a grey color. This can indicate worn out parts in the cylinder or the hydraulic unit.
7. Take care to prevent dirt and water getting inside the oil tank. Replace the cover.
8. Fill with hydraulic oil Tellus #46 BRAND or an equivalent with similar specifications.
9. Replace the oil fill cap.
10. Purge air from the hydraulic system.

### **Oil Disposal**

Used oil products must be disposed of in a proper manner following your local regulations.





**OVERALL MACHINE PARTS DIAGRAM**

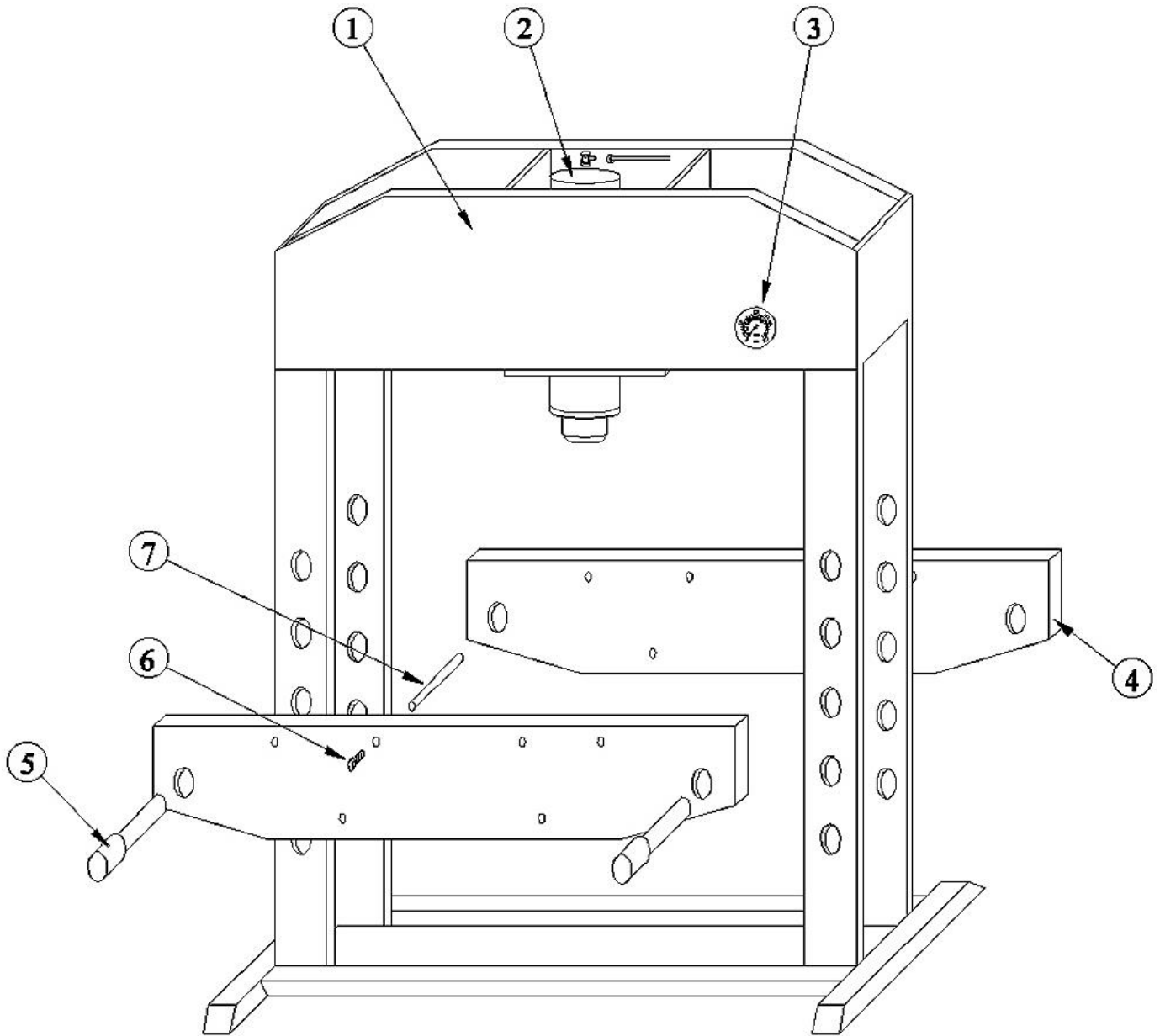



### Overall Machine Parts List

Item	Description
1	Mail Frame
2	Cylinder
3	Pressure Gauge
4	Plate
5	Plate Fixing Shaft
6	Bolt
7	Plate Shaft



**RAM PARTS DIAGRAM**

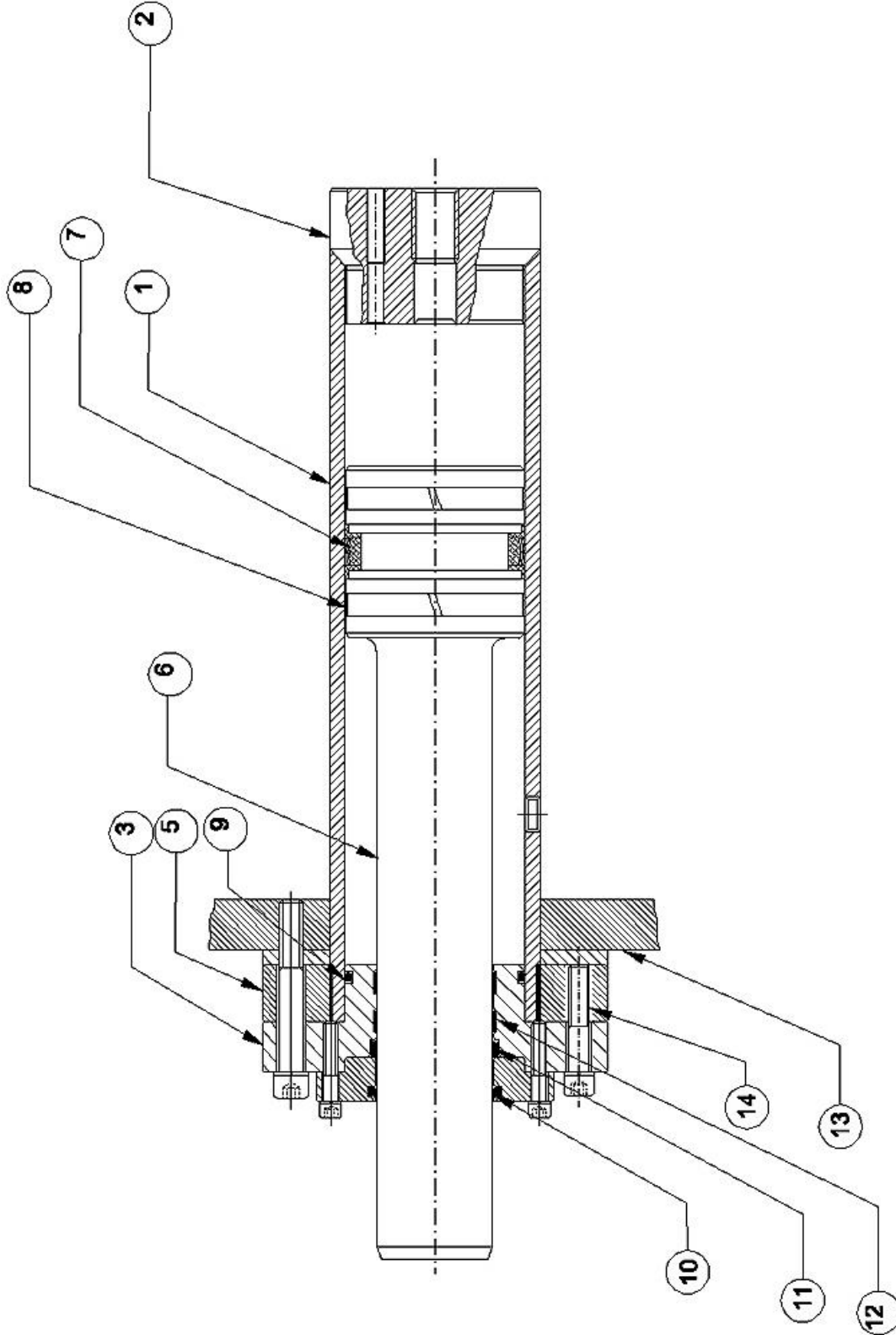



### Ram Parts List

Item	Description
1	Cylinder
2	Cylinder Cap
3	Neck Flange
4	Dust Cap
5	Cylinder Flange
6	Piston
7	Compact Seal
8	Teflon Stripe
9	O-Ring
10	Scraper
11	Neck Seal
12	Bushing Band
13	Press Frame
14	Bolt



# ELECTRIC HYDRAULIC PUMP PARTS DIAGRAM

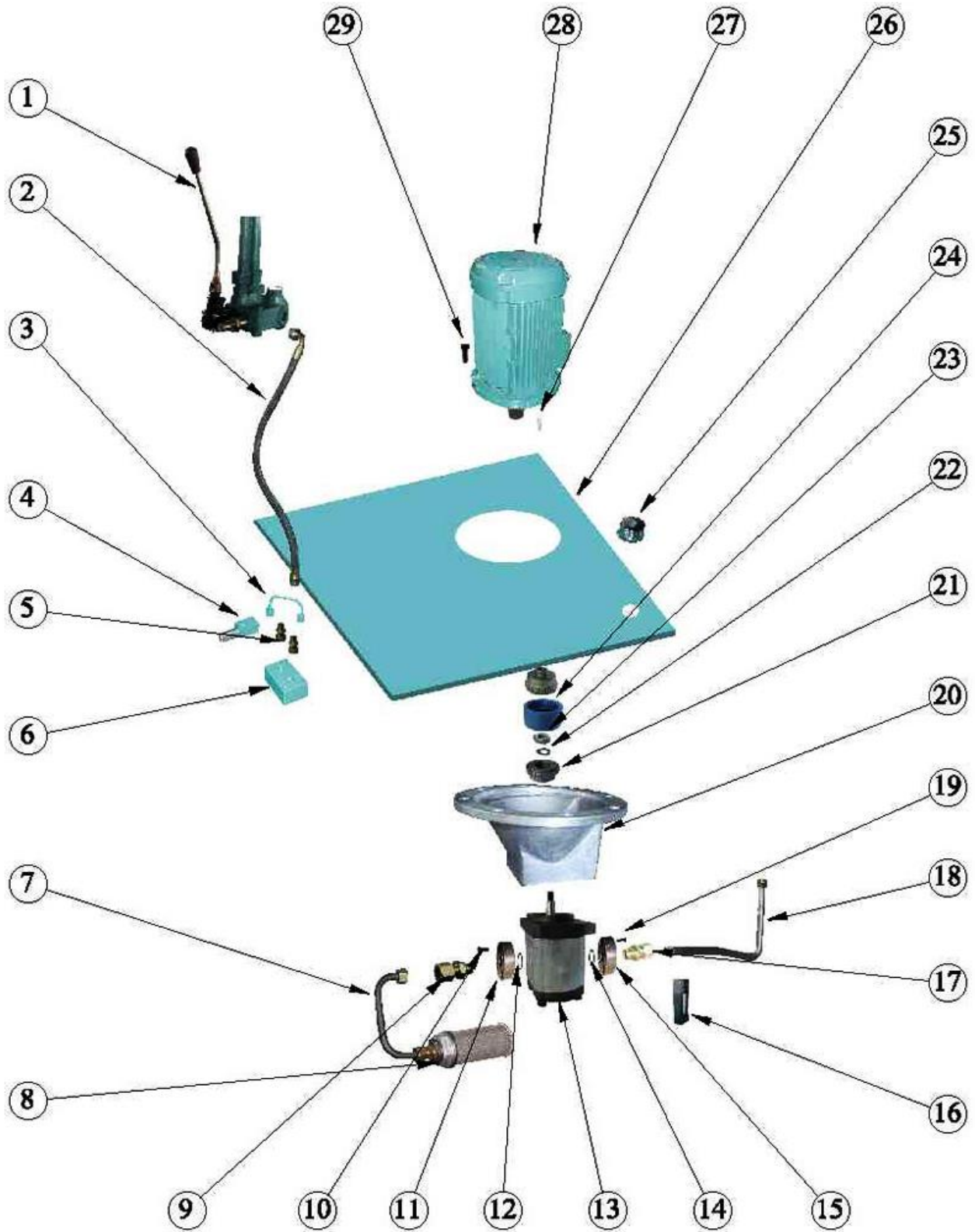



### Electric Hydraulic Pump Parts List

Item	Description
1	Head Arm Control
2	Pressure Pipe
3	Crossover Tube
4	Emergency Vent Block
5	Block Bolts
6	Distributor Block
7	Absorb Pipe
8	Absorb Filter
9	Block Pressure Bolt
10	Connecting Bolt
11	Connecting Plate
12	O – Ring
13	Hydraulic Pump
14	O – Ring
15	Connecting Plate
16	Oil Sight Gauge And Temperature Read–Out
17	Pressure Bolt
18	Pump Pressure Bolt
19	Connecting Bolt
20	Pump Flange
21	Coupling
22	O – Ring
23	Plastic Coupling
24	Motor Coupling
25	Basket
26	Oil Tank Cover
27	Motor Shaft Key
28	Motor
29	Flange Bolt





## ELECTRICAL SCHEMATIC

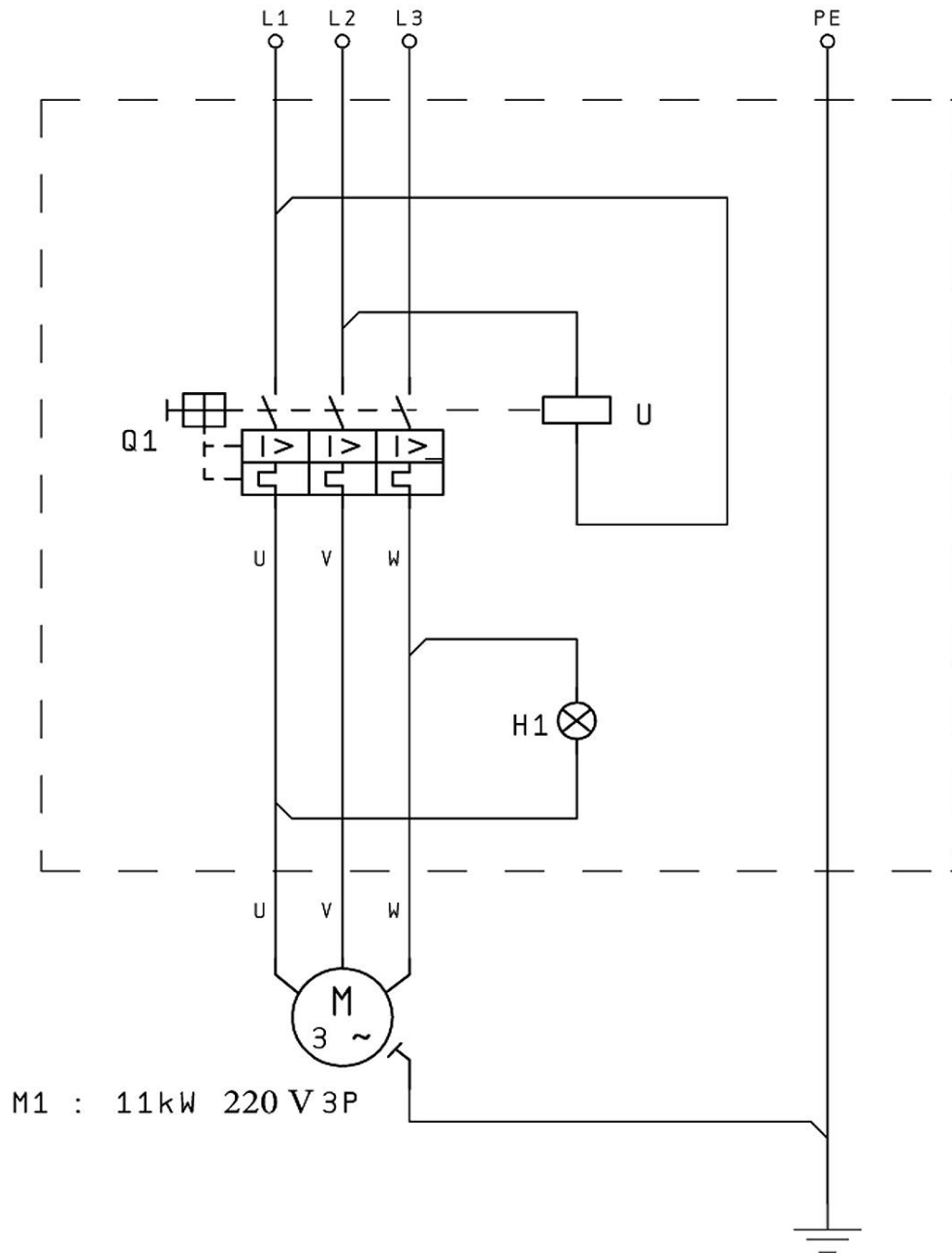

### Electrical Parts List

- Q1 Motor Protection Overload Thermal Relay (9-14A) (GV2 ME16 Telemecanique)
- H1 Indicator Lamp (GV2 SN33 Telemecanique)
- Enclosure (Plastic Box) (GV2 MC01 Telemecanique)
- Emergency Stop Module (GV2 K021 Telemecanique)



## TROUBLESHOOTING

 **WARNING:** Make sure the electrical disconnect is OFF before working on the machine.

FAULT	PROBABLE CAUSE	REMEDY
Low Pressure	Gauge Failure Plugged oil passage in relief valve or check valve. Oil leak at hose fittings. Oil leak with-in cylinder. Oil filter plugged.	Check pressure gauge. Repair or replace as needed. Clean valve(s). Replace if needed. Check and tighten any loose or leaking fittings. Replace cylinder oil seals. Clean hydraulic tank and system.
Slow operation	Oil very thick due to cold temperature. Low oil level sucking air into the system. Oil leak.	Normal oil operation temperature is 68-104°F (20-40°C). Control oil temperature as needed. Check oil level. Add oil as/if needed. Repair any oil leak(s) immediately.



NOTES



NOTES



NOTES



**BAILEIGH INDUSTRIAL, INC. 1625 DUFEEK DRIVE MANITOWOC, WI 54220**

**PHONE: 920. 684. 4990 FAX: 920. 684. 3944**

**[www.baileigh.com](http://www.baileigh.com)**

**BAILEIGH INDUSTRIAL, INC. 1455 S. CAMPUS AVENUE ONTARIO, CA 91761**

**PHONE: 920. 684. 4990 FAX: 920. 684. 3944**

**BAILEIGH INDUSTRIAL LTD. UNIT D SWIFT POINT**

**SWIFT VALLEY INDUSTRIAL ESTATE, RUGBY**

**WEST MIDLANDS, CV21 1QH UNITED KINGDOM**

**PHONE: +44 (0)24 7661 9267 FAX: +44 (0)24 7661 9276**

**[WWW.BAILEIGHINDUSTRIAL.CO.UK](http://WWW.BAILEIGHINDUSTRIAL.CO.UK)**

**BAILEIGH INDUSTRIAL GMBH HOFENER STRAÙE 64**

**70736 FELLBACH**

**DEUTCHSLAND**

**[WWW.BAILEIGHINDUSTRIAL.DE](http://WWW.BAILEIGHINDUSTRIAL.DE)**

**BAILEIGH INDUSTRIAL PTY. LTD.**

**P.O Box 1573, 126 MELROSE DRIVE TULLAMARINE,**

**VIC 3043 AUSTRALIA**

**[WWW.BAILEIGHINDUSTRIAL.COM.AU](http://WWW.BAILEIGHINDUSTRIAL.COM.AU)**