



Original

Installation And Service Manual

MOBILE SINGLE POST LIFT Model: SML-7

Cargo Claims

If there is any missing or damaged product during transportation, the buyer must notate on the shipping paperwork or refuse the shipment. NOTATE ALL DAMAGE OR REFUSE DAMAGED SHIPMENT!

DANGER

Read the entire contents of this manual before using this product. Failure to follow instructions and safety precautions could result in serious injury or even death. Make sure all other operators also read this manual. Keep this manual near the machine so that it can be seen by all users. By proceeding with installation and operation, you agree that you are fully understand the contents of this manual and take full responsibility for the use of the product.

CONTENTS

PROFILE	1
IMPORTANT SAFETY INSTRUCTIONS	3
I. PRODUCT FEATURES AND SPECIFICATIONS	5
II. INSTALLATION REQUIREMENT	8
III. INSTALLATION STEPS	19
IV. EXPLODED VIEW	23
V. TEST RUN	26
VI. OPERATION INSTRUCTIONS	27
VII. MAINTENANCE SCHEDULE	28
VIII. TROUBLE SHOOTING	29
IX. CAR LIFT SAFETY TIPS	30
X. LIFT DISPOSAL	30

PROFILE

This installation and service manual is specially prepared for you. Your new lift is the product of over a decade of continuous research, testing and development and is the most technologically advanced lift on the market today.

Please make sure to read through this manual before operating the lift.

Record the information on the nameplate label here:

Model No.: _____

Serial No.: _____

Manufacturer date: _____

WARRANTY

The warranty period for the steel structure part of new car lift is 5 years, hydraulic components, bronze bushings and sliders are under warranty for 3 years, and electrical components warranty for 2 year. Rubber pads are without warranty. During the warranty period, the manufacturer will repair or replace the defective parts free of charge including shipping costs.

This warranty does not cover damage caused by normal wear and tear, improper use, damage in transit, or damage caused by lack of maintenance.

This warranty is unique and supersedes what is expressed and implied in all other warranties. The manufacturer shall not be liable for any particular, indirect or accidental damage resulting in breach of or delay in the execution of the warranty. The manufacturer reserves the right to design and improve the product and has no obligation to make notice of the changes in advance.

The product warranty based on the above clause is based on the model number and serial number of the equipment. This information must be provided in conjunction with all warranty information at the time of service and warranty.

SAFETY WARNING LABEL



Fig.1

IMPORTANT SAFETY INSTRUCTIONS

In order to properly maintain your product and ensure operator safety, it is the responsibility of the product owner to read and follow these instructions!

1. Ensure product installation full complies with all applicable local and national rules, ordinances and regulations;
2. Ensure that all operators are properly trained, know how to operate the unit safely, and are properly supervised;
3. Do not operate the lift until you are sure all parts are in place and operating correctly;
4. Keep your hands and feet away from the machine. Keep hands and feet away from any moving parts. Keep your feet away from the lift as it descends and avoid pressing on pointed objects;
5. Keep the work area clean. A cluttered workspace can lead to injuries;
6. The machine is only approved for indoor installation and use. Outdoor installation is prohibited;
7. Only trained operators are allowed to handle the lift machine. All untrained persons must stay away from the workplace. Never allow untrained persons to handle or operate the machine;
8. Use the lift properly. Use the lift in the correct way;
9. Warning! Keep persons and objects from the lift when lifting the a vehicle;
10. If the vehicle is at risk of falling, make sure no one is around the lift;
11. Before preparing to approach or service the vehicle, ensure that the safety device is in effect;
12. Dress appropriately when operating machines, and consider wearing non-slip steel-toe shoes for safety;
13. Beware of electric shock. In order to protect the operator from electric shock, the lift in use must be grounded. Do not connect the green wire to the terminal. This is the ground wire;
14. Danger! The power supply used in this type of lift has high voltage. Please disconnect the power supply before any circuit repair. Unplug in case the power supply is accidentally switched on during maintenance;
15. Warning! There is a risk of explosion. There are parts in the equipment that produce arc light and spark. Do not operate near flammable gas. This machine should not be placed in the lounge or basement;
16. Maintain with care. Keep the machine clean for better and safer operation. Perform proper lubrication and maintenance procedures according to the manual. Keep handles or buttons clean, dry, and free of oil;
17. Stay alert. Use common sense to observe what you are doing and stay alert;

18. Check for damaged parts. Check for adjustments to moving parts, damage to parts, or anything that may affect their operation. Do not use the machine if the parts are damaged;
19. Do not remove relevant safety parts from the machine. Do not use a lift if it is damaged or missing;
20. Operate the lift only at temperature between 41°F to 104°F (5°C to 40°C).



DANGER Be very careful when installing, operating, maintaining or repairing this equipment. Failure to comply may result in property damage, product damage, injury or (in very rare cases) death. Ensure that only authorized personnel operate the equipment. All repairs must be carried out by an authorized technician. Do not modify the machine, this voids the warranty and increases the probability of personal injury or property damage. Ensure to read and follow this instructions on the label.

I. PRODUCT FEATURES AND SPECIFICATIONS

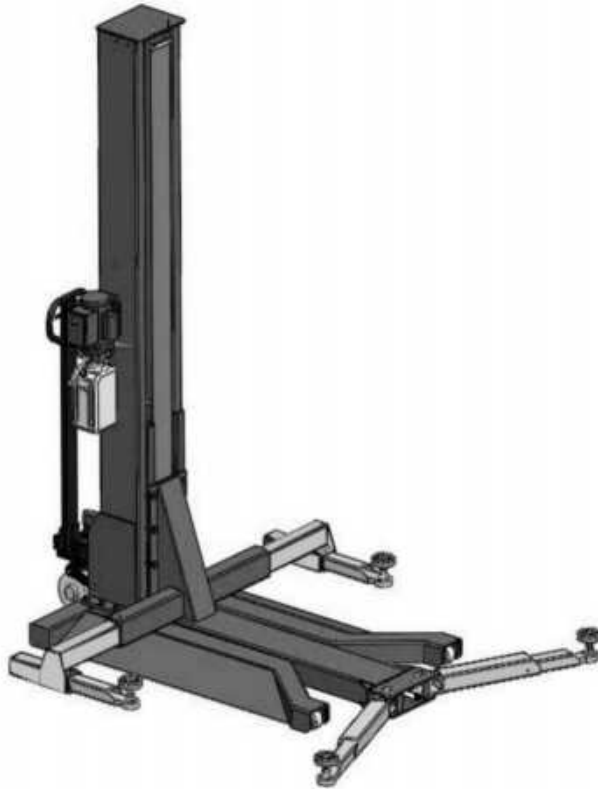

Fig.2

MOBILE SINGLE POST MODEL SML-7 FEATURES

- Lifting capacity: 7000lbs
- Compact design.
- Hydraulic cylinder is designed and made on high standard, with utilizing imported oil seal in cylinder.
- Self-lubricating UHMW polyethylene sliders and bronze bush.
- Manual safety release, with dual safety devices.
- Adjustable arms with stackable and screwed type rubber pads.

MODEL SML-7 SPECIFICATIONS

Arm Swings View

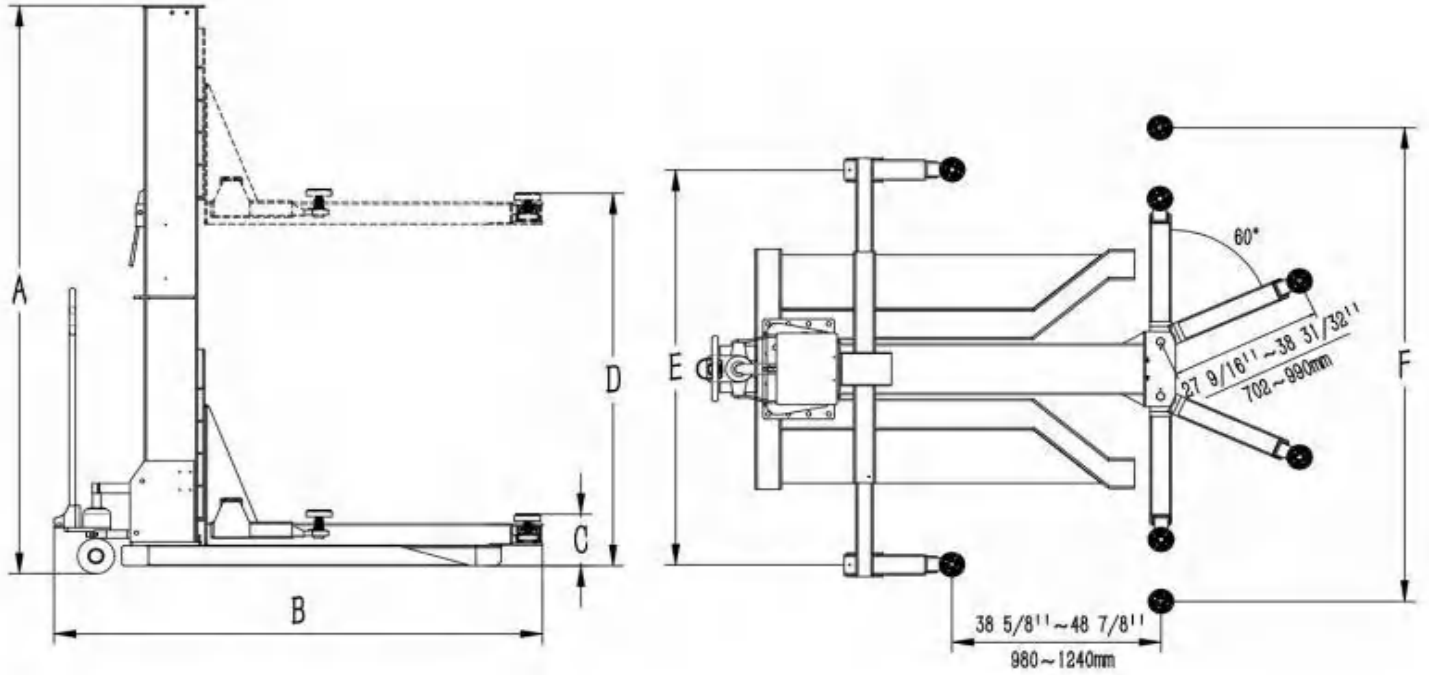

Fig.3

Model	Lifting Capacity	Lifting Time	A	B	C	D	
			Overall Height	Overall Width	Minimum Pad Height	Max. Lifting Height	
SML-7	7000lbs	84S(110V) 32S (220V)	108 7/8"	90 3/8"	4 11/32"	Without extension adapters	Include extension adapters
						71 7/8"~74 3/8"	74 27/32"~ 77 3/8"

Model	D		E	F	Motor
	Max Safety Lock Height		Inside arms stretch dimension	Outside arms stretch dimension	
SML-7	Without extension adapters	Include extension adapters	50"~75 7/8"	60 1/4"~ 76 3/4"	1.0HP
	68 5/16"~70 27/32	71 5/16"~73 13/ 16"			

II. INSTALLATION REQUIREMENT

A. TOOLS REQUIRED

✓ Level Bar



✓ Spanner Wrench(12")



✓ Wrench set: (10", 13", 14", 12",
17", 19", 24", 30")



✓ Pliers



✓ Screw sets



✓ Tape Measure(7.5m)



✓ Socket Head Wrench: (4", 5", 6")



Fig.4

B. Equipment storage and installation requirements.

- 1 . Store the equipment in a dry, non-moldy, non-flammable environment.
- 2 . When installing the device, take safety precautions according to the instructions to avoid device damage.
- 3 . Do not install the device outdoors if the installation area is not protected.
- 4 . During installation, all parts should be fastened to ensure the stability and smooth operation of the machine.
- 5 . After installation, the whole machine should be checked to make sure that every component is working properly.

C. Power supply

1. You are required to use a licensed and qualified electrician for the installation process.
2. The power supply should be 110VAC/60HZ, with a cord larger than 12AWG, and must be properly grounded.

⚠ DANGER All electrical wiring must be performed by a licensed and certified electrician. Attempting to connect the circuit without proper certification may cause damage to the lift or electrocution, resulting in serious injury or death.

III. INSTALLATION STEPS

A. Location of Installation

1. Building plan: Please refer to the building's floor plan when selecting your ideal installation location. Ensure the location you choose does not conflict with the building's floor plan.
2. Installation space: Ensure there is enough space for the lift. Accurately measure the front, back, side and top mounting dimensions and refer to the below figure data (**See Fig. 5**).
3. Overhead obstacle: Check for overhead obstacles, such as building supports, heaters, lights, wires, and low ceilings, etc..
4. Floor: install lift only on flat surface.

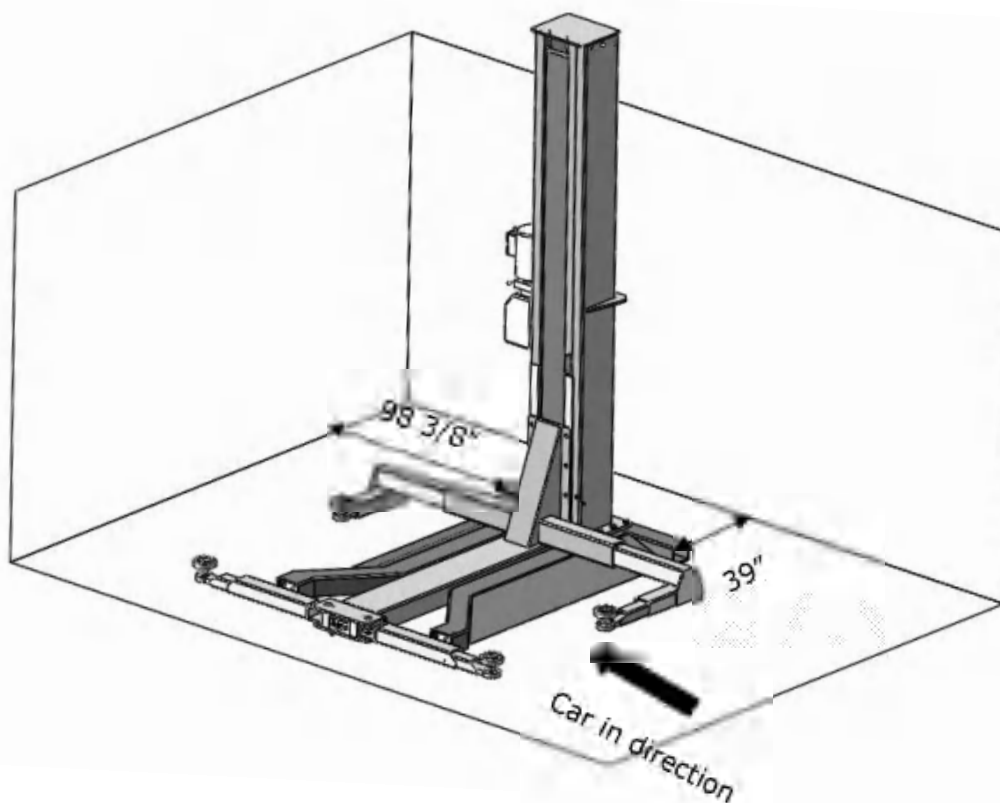

Fig.5

⚠ CAUTION Installing the lift on a surface with slopes more than 3° could lead to injury or even death. The lift is designed for installation on a flat and level surface only. (Defined as no more than 3/8" difference over the installation area). If the floor cannot be leveled, consider changing installation locations.

ATTENTION: Lift installation and concrete construction must comply with the latest version of the national standard "Automotive Lifts - Safety Requirements for Construction, Testing and Verification".

B. Check the parts before assembly

1. Received package (lift and hydraulic power unit) **(See Fig. 6)**

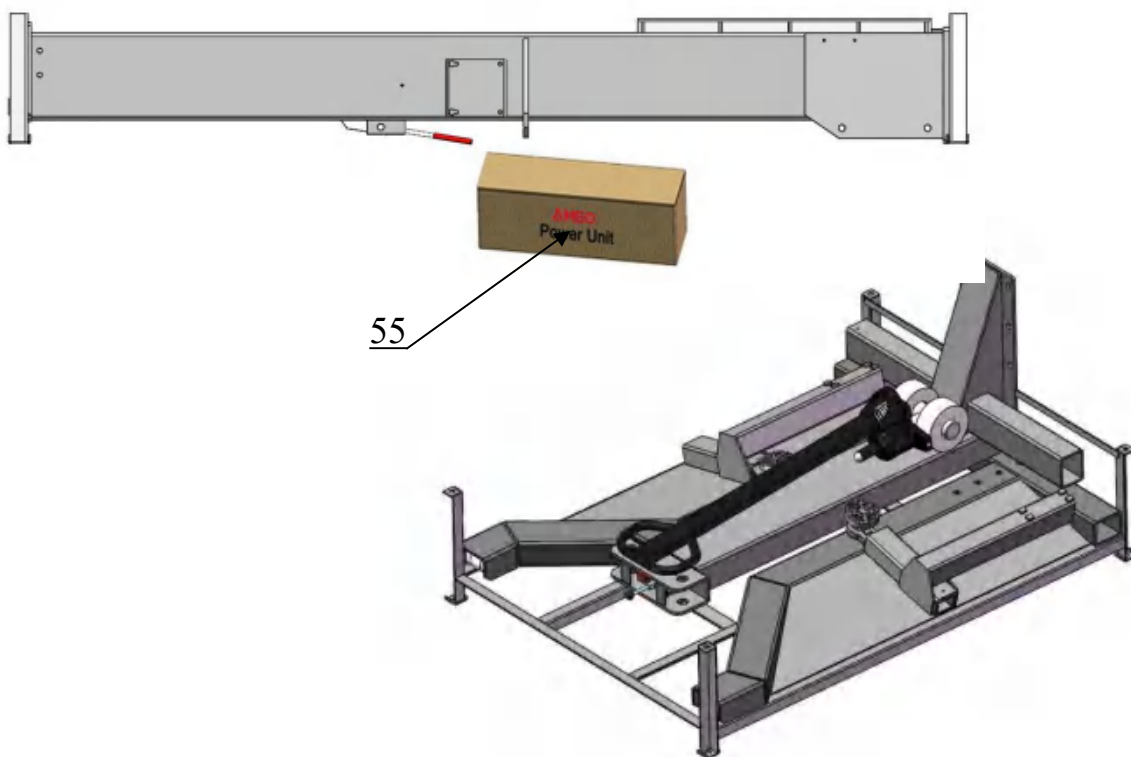

Fig.6

2. Remove the packaging of the machine ⇒ Take off the packing rack.
3. Move aside all the parts and check according to the shipment parts list (See Fig.7)

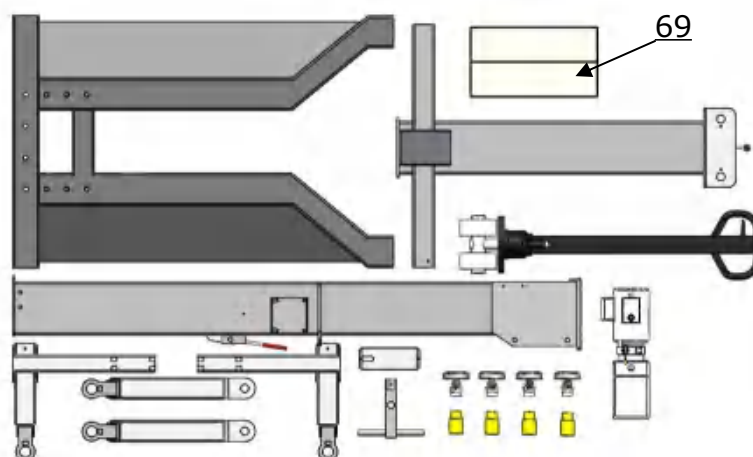

Fig.7

4. Open the parts box, and check all the parts according to the parts list.



Fig.8

5. Open parts bag 1 & parts bag 2, check all the parts according to the parts bag list.



Fig.9

C. Confirm the installation position and place the base onto it. (See Fig.10)

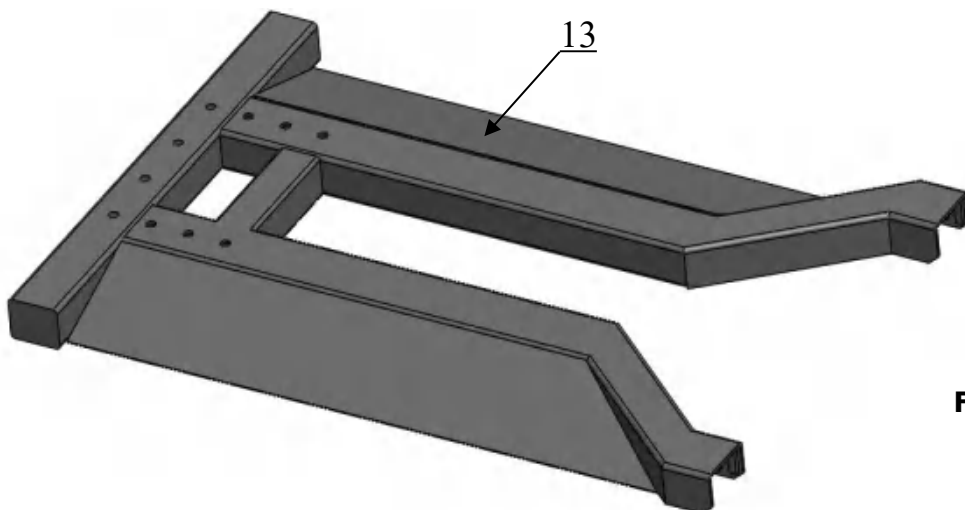

Fig.10

D. Install column, connect cylinder oil hose and install lift platform

1.Lay the column flat to the ground. (See Fig.11)

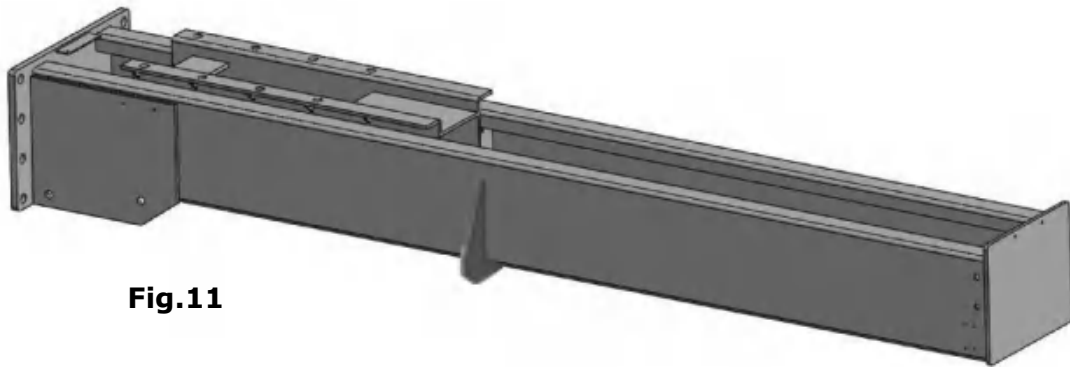
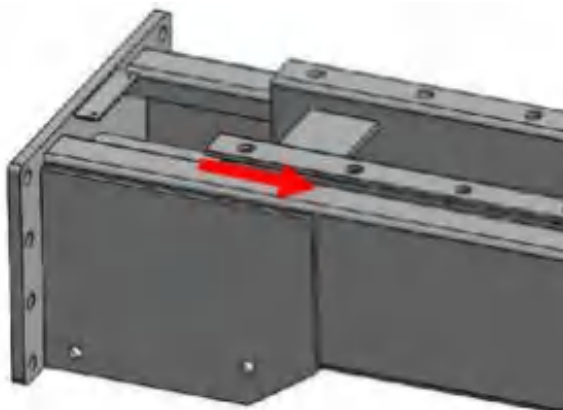
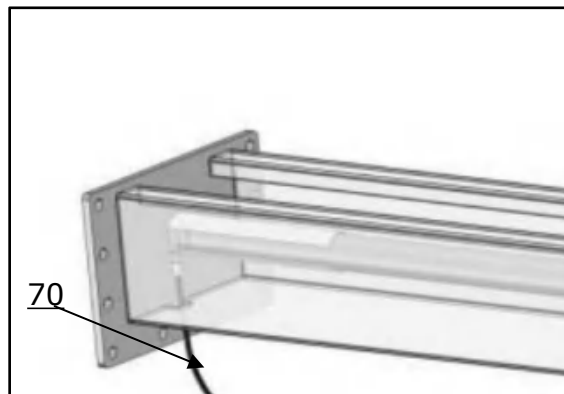

Fig.11

2.Connect oil hose to cylinder. (See Fig.12)



A: Pull out the carriage around 8" (200mm) from base plate.



70

B: Pass the oil hose through the hole on the backside of column and connect it to the cylinder fitting and tighten.

Fig.12

3. Position the column onto the base, align the mounting holes, and install with bolts. Check the column plumbness with level bar, adjust with shims if necessary. (See Fig.13)

51 M20*50 Hex bolt with flat washer, lock washer

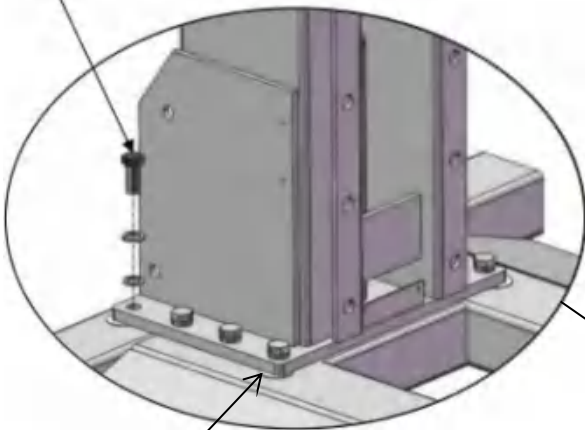

71/72 Adjust with 3/64" or 5/64" shims if necessary.

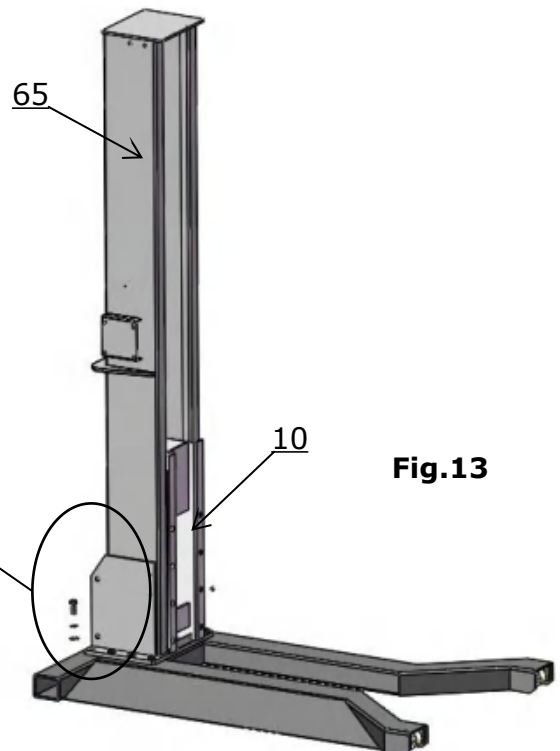

Fig.13

4. Fix lifting platform to carriage. (See Fig.14)

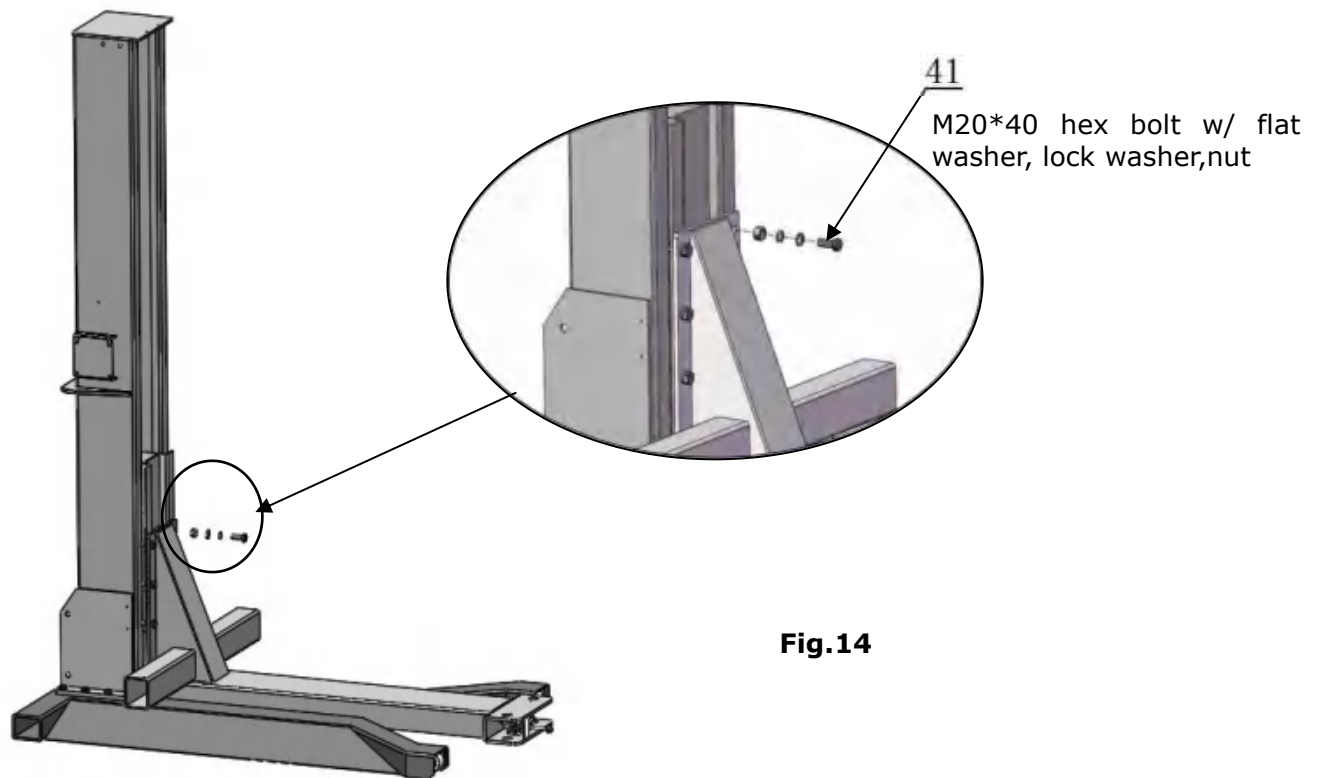

Fig.14

E. Install power unit, retainer and connect oil hose.

1. Install power unit. See fig 15.

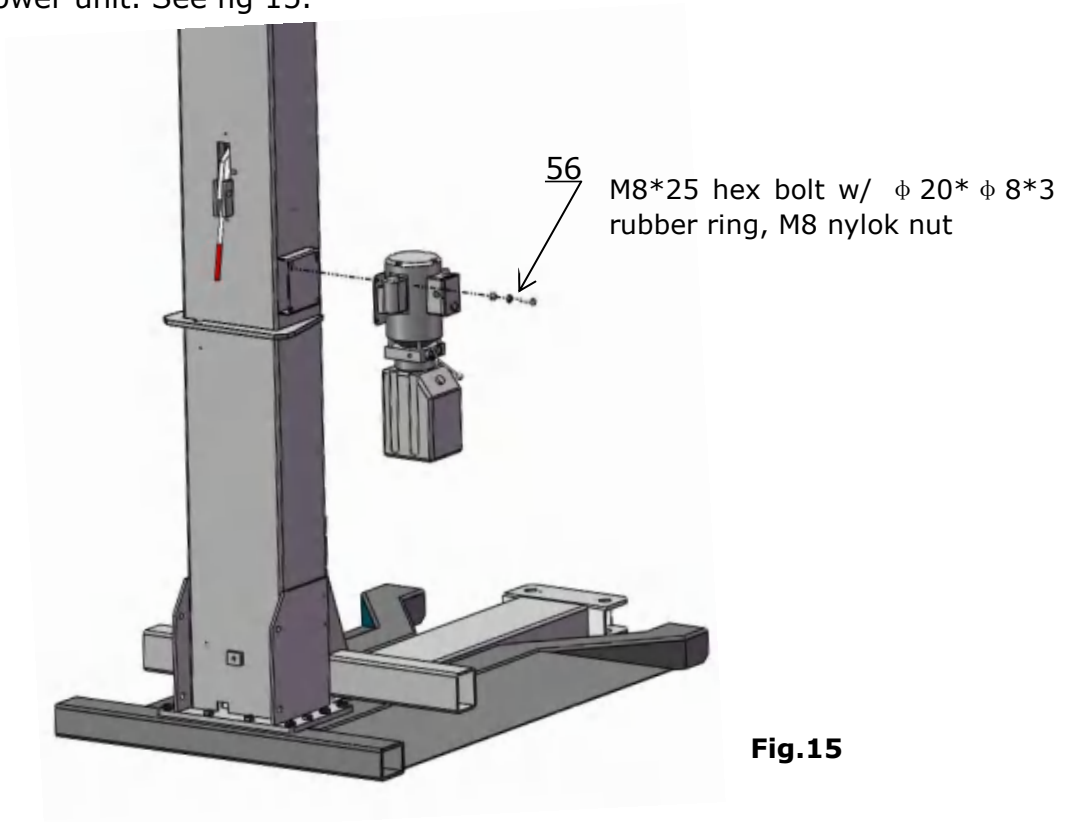
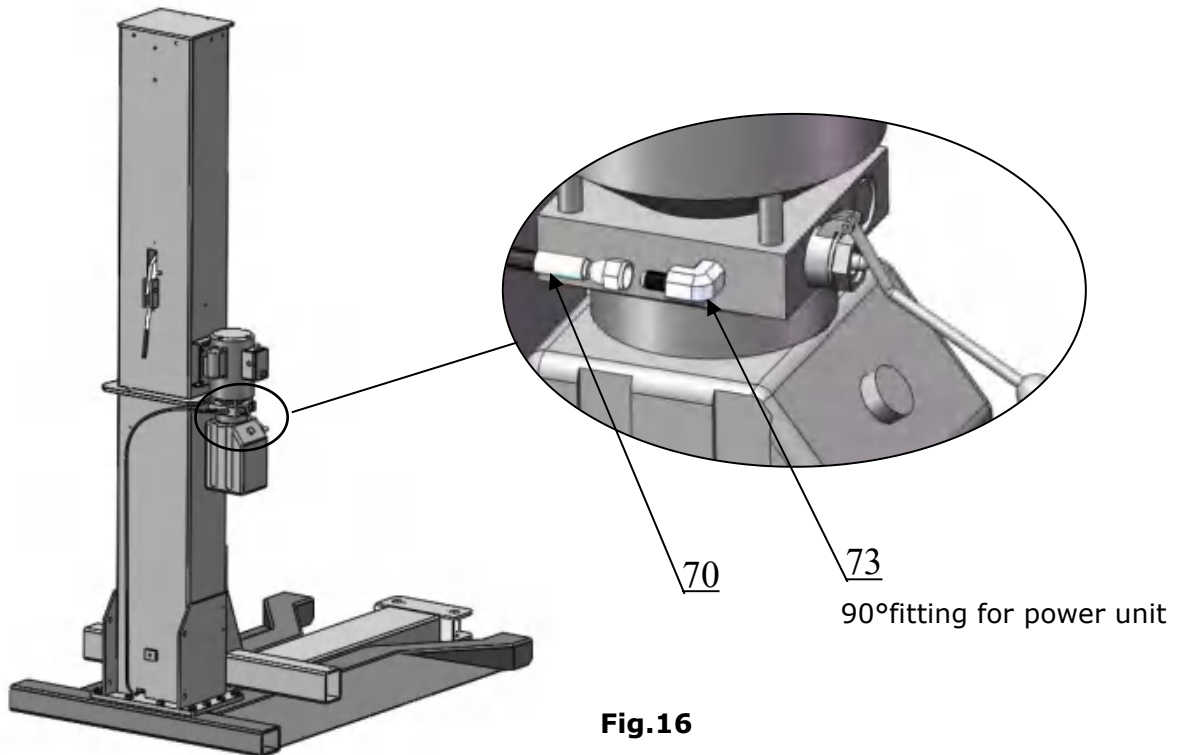

Fig.15

2. Connect oil hose.

Install the 90° fitting to the power unit, then connect it with the oil hose that comes from the cylinder.



3. Install retainer

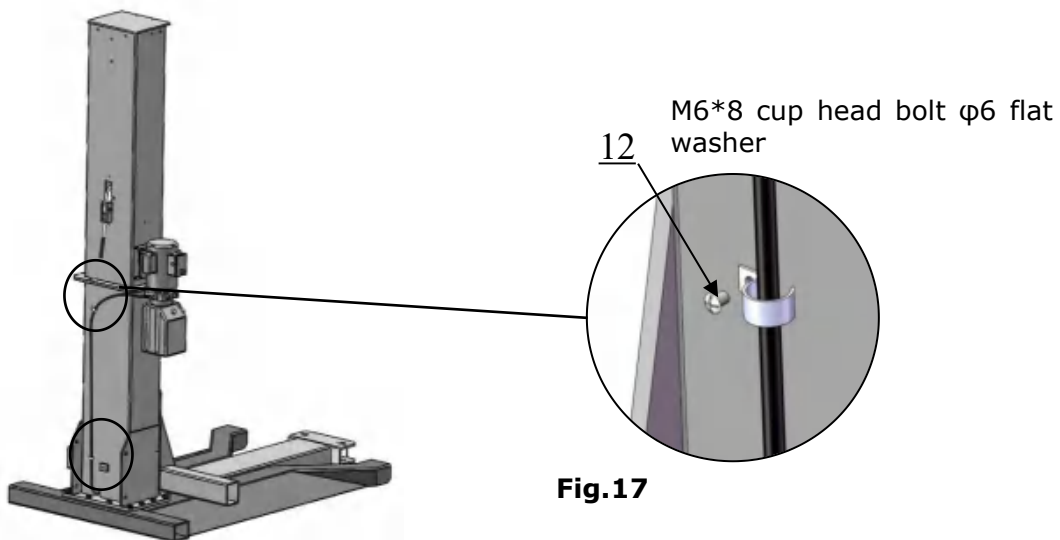

Note: Tighten all the hydraulic fittings after installation.

4. Fill the reservoir with hydraulic oil.

Note: In consideration of power unit's durability and keep the equipment running in the perfect condition, please use hydraulic oil 46#.

F. Connect the power with schematic circuit diagram according to the requirement on the motor plate.

Note: To ensure the safety of operators, the lift must be grounded. Test the lift after installation to check if works fine.

Single phase motor (see fig 18)

Connect the two hot wires of power supply respectively to the terminals of AC contactor marked L1 and L3 . Connect ground wire to ground terminal.(Follow the circuit diagram shown on the back of the motor box for wire connection)

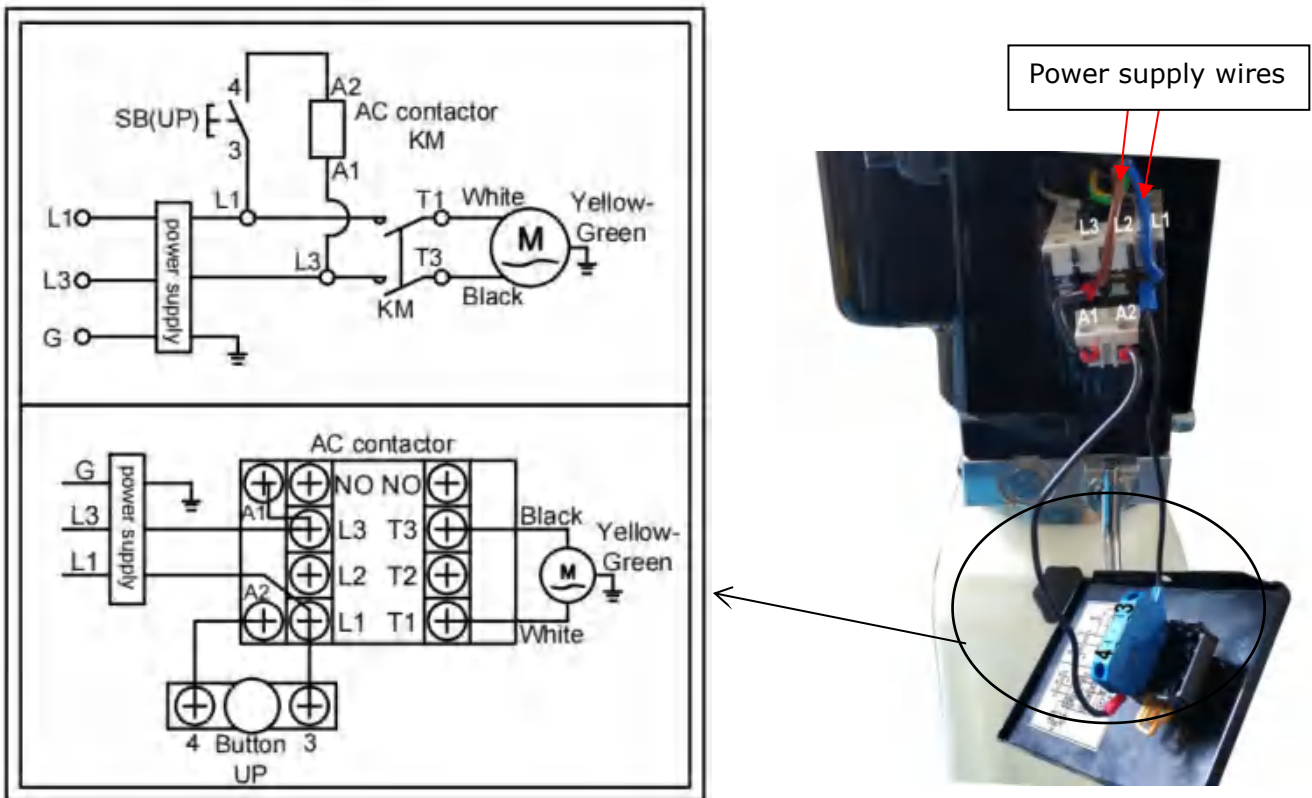
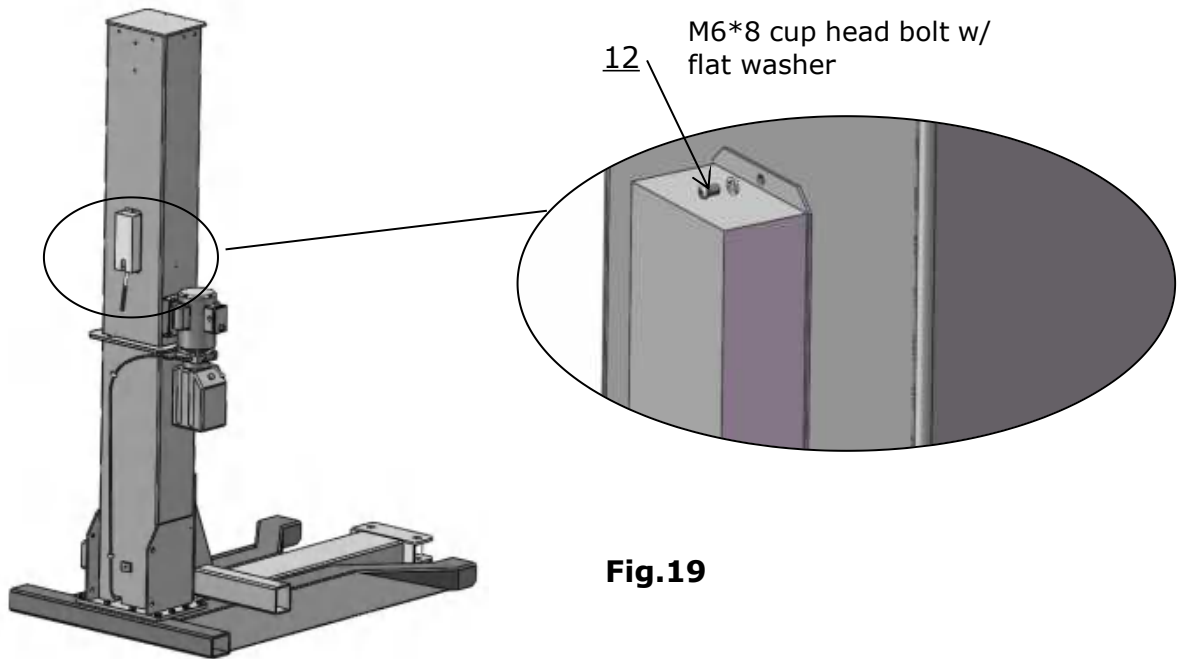

Fig.18

⚠ DANGER Do not use the lift if the wires are damaged or severely worn. If the vehicle rises without noticing damage or extreme wear, carefully lower the vehicle to the ground. Once the lift is on the ground, remove it, disconnect the power, and arrange for protection.

G. Install safety device cover (see fig.19)



H. Install lifting arms.

1. Install inside lifting arms.

Insert the inside lifting arm into square tube, tighten with M8*20 limit bolt to prevent the lifting arms from pulling out.

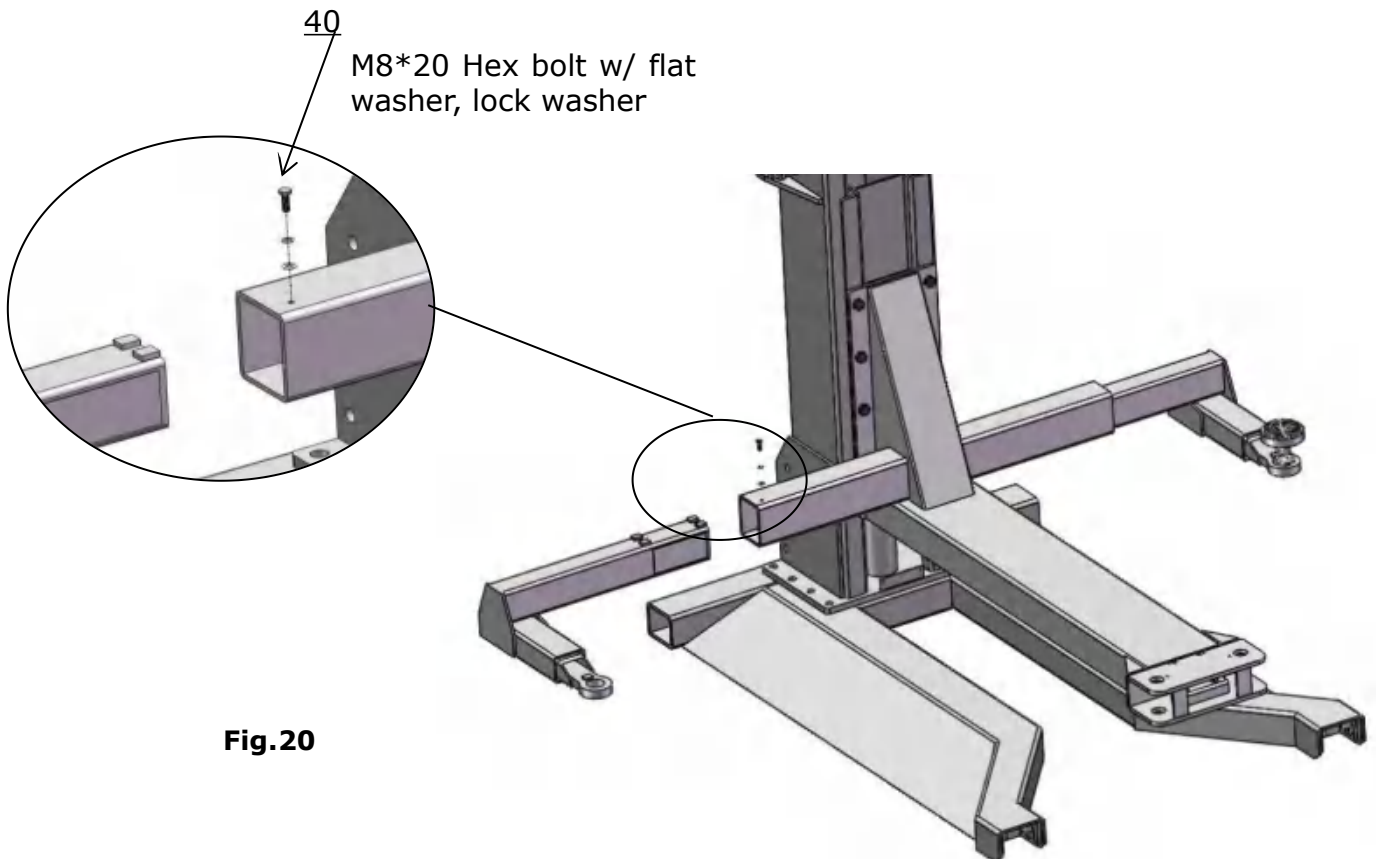

2. Install outside lifting arms.

Align the outside lifting arm with the hole, then insert the arm pin, and tighten with M8*12 flat head bolt. See fig 21.

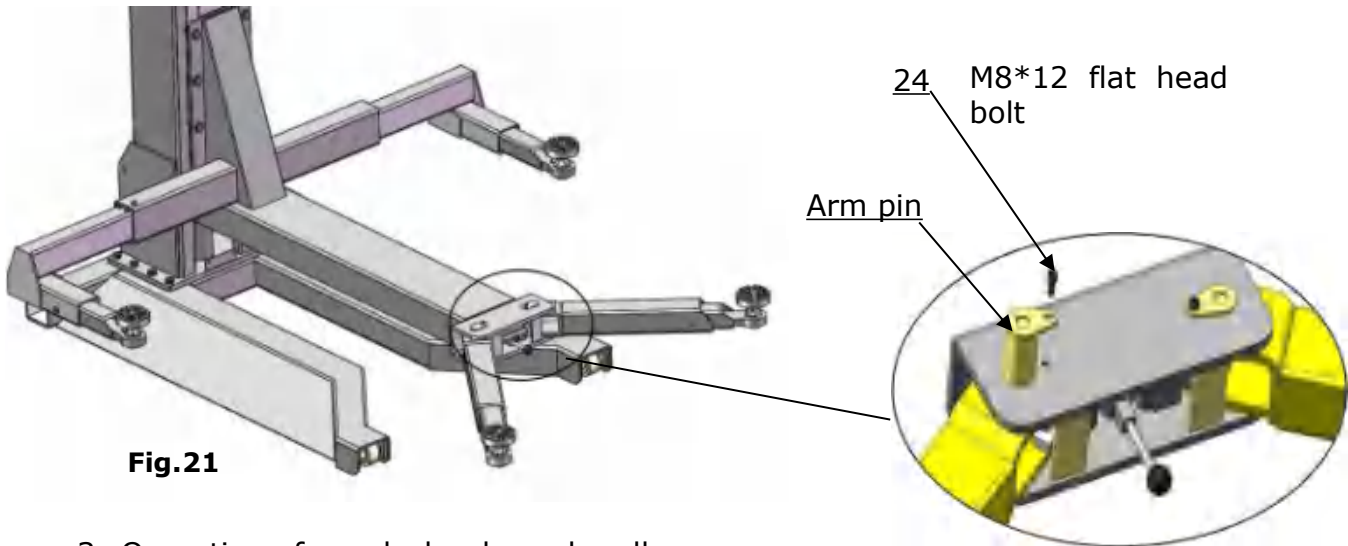

Fig.21

3. Operation of arm lock release handle

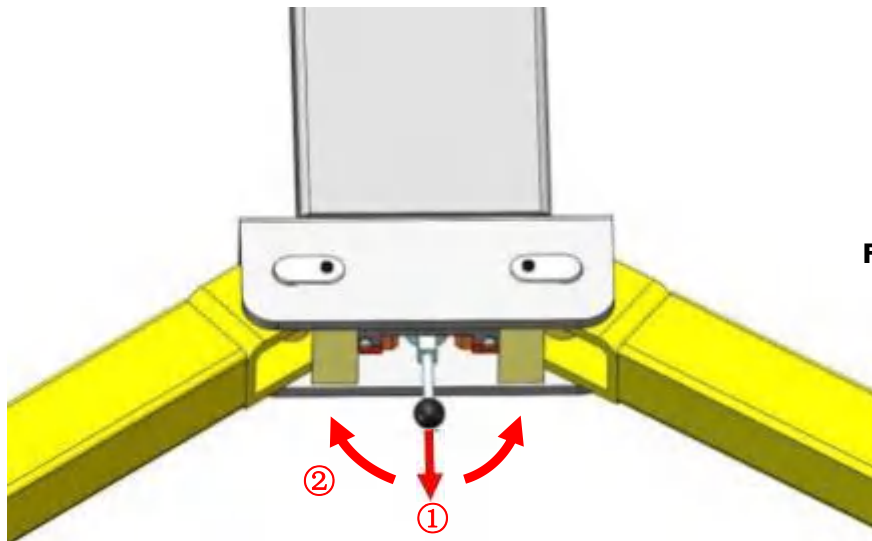

Fig.22

- ① Pull out the arm lock release handle.
- ② Turn the arm lock release handle left or right to release the both arm locks to adjust the position of arms.

⚠ DANGER Moon gear must be positioned and adjusted correctly. The lift should not be operated until the gears are fully engaged, and it is important to regularly check and adjust the arm restraint gears on all four arms. Failure to do so may result in vehicle damage, injury, or even death.

⚠ WARNING Each arm restraint assembly must be inspected and adjusted before you use the Lift each and every time. Do not operate the Lift if any of the four arm restraint systems are not functioning properly. Replace any broken components or components with broken teeth with authorized replacement parts only.

I. Install fabric curtain cover . See fig 23.

Follow the steps below to install the fabric curtain cover.

3 M6*95 hook bolt, w/ $\phi 6$ flat washer and M6 nylok

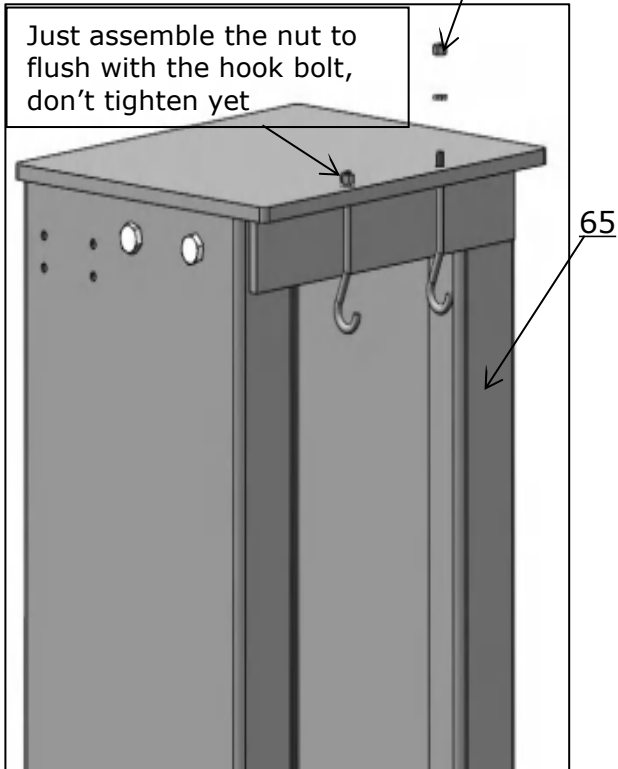

1. Install the hook bolt into the top plate.

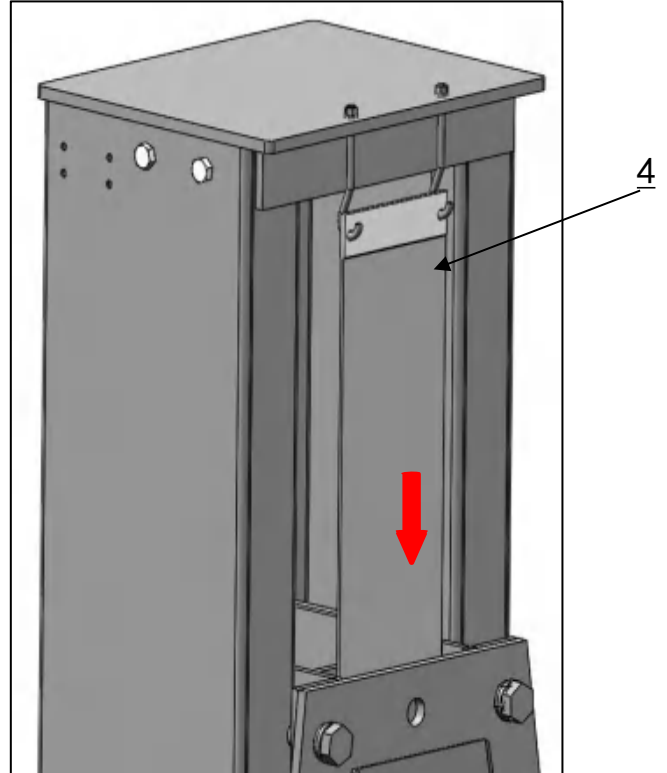

2. Hook the fabric curtain cover to the hook bolt, pass the other side through the upper hole of the carriage, then go downwards from inner side.

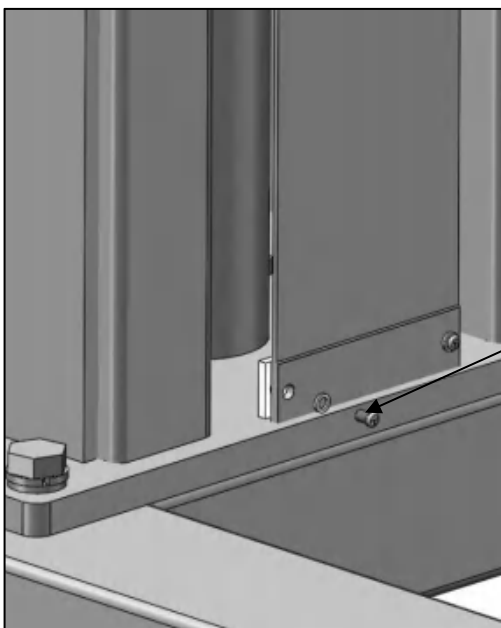

Fix with M6*8 round head bolt with flat washer

3. Pass the fabric curtain cover through the carriage to the bottom mounting plate and fix with round head bolts.

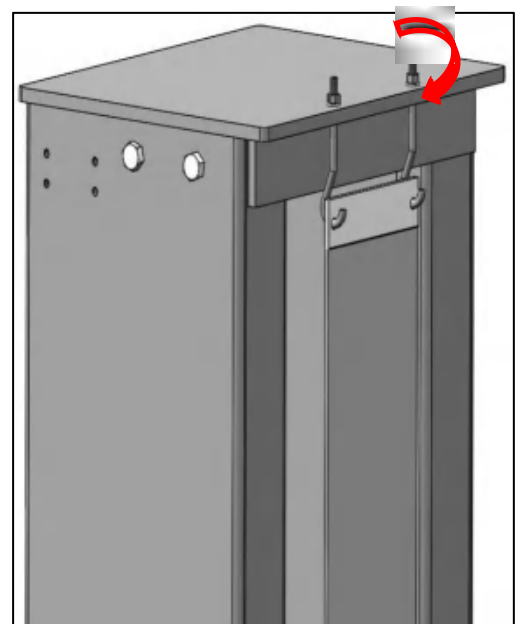

4. Adjust the nuts until the fabric curtain cover is straight.

Fig.23
17

J. Install mobile wheel dolly.

Please install following the below steps.

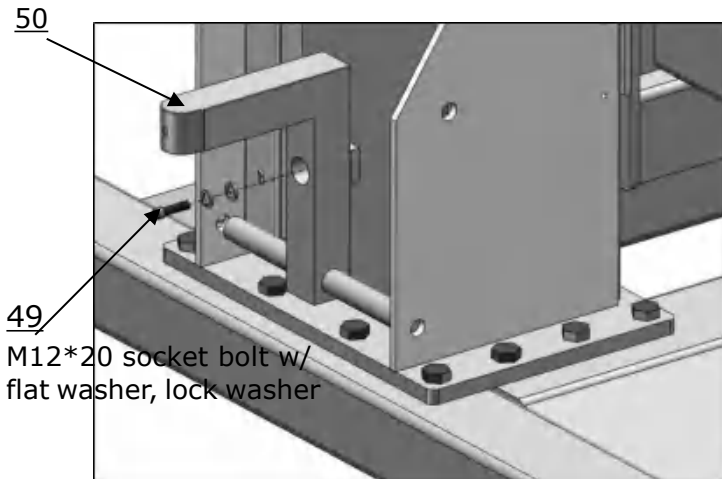

1. Assemble the dolly fixing square tube (50) to the mounting plate at the backside of column with socket bolt.

Fig.24

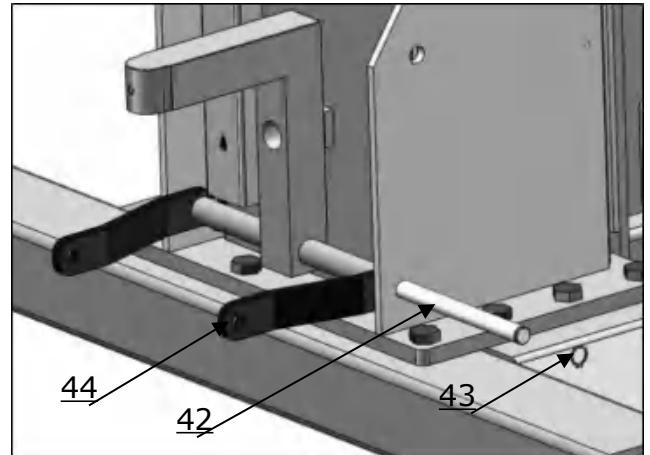

2. Connect the dolly fixing square tube and the dolly connecting board (44) with pin, and limit with clip ring at both ends.

Fig.25

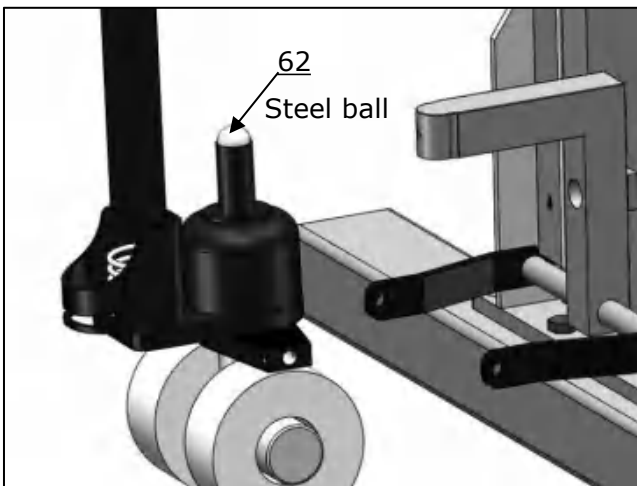

3. Place the steel ball on the top of dolly cylinder. Assemble the wheel dolly with dolly fixing square tube.

Fig.26

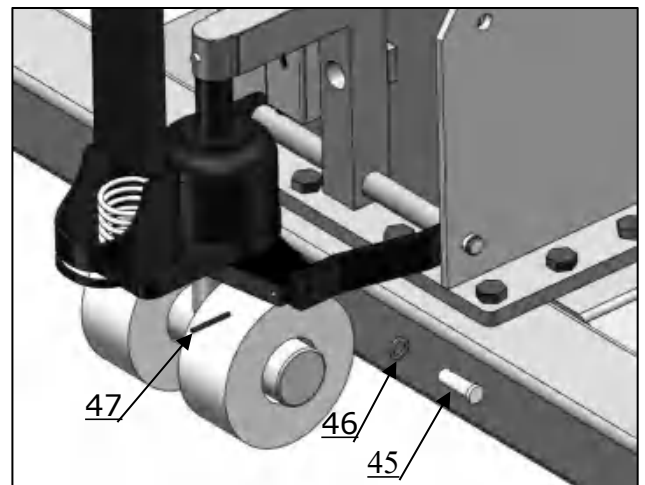

4. Assemble the dolly connecting board and dolly cylinder assembly with dolly fixing pin, and limit with snap ring.

Fig.27

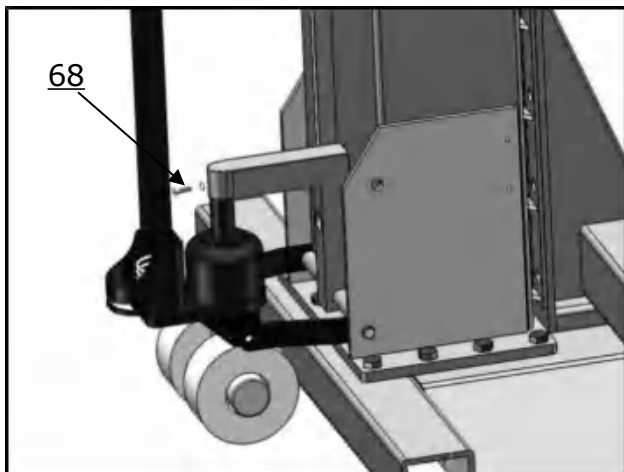

5. Install limit bolt (M8*16 hex bolt w/ lock washer)

Fig.28

IV. EXPLODED VIEW

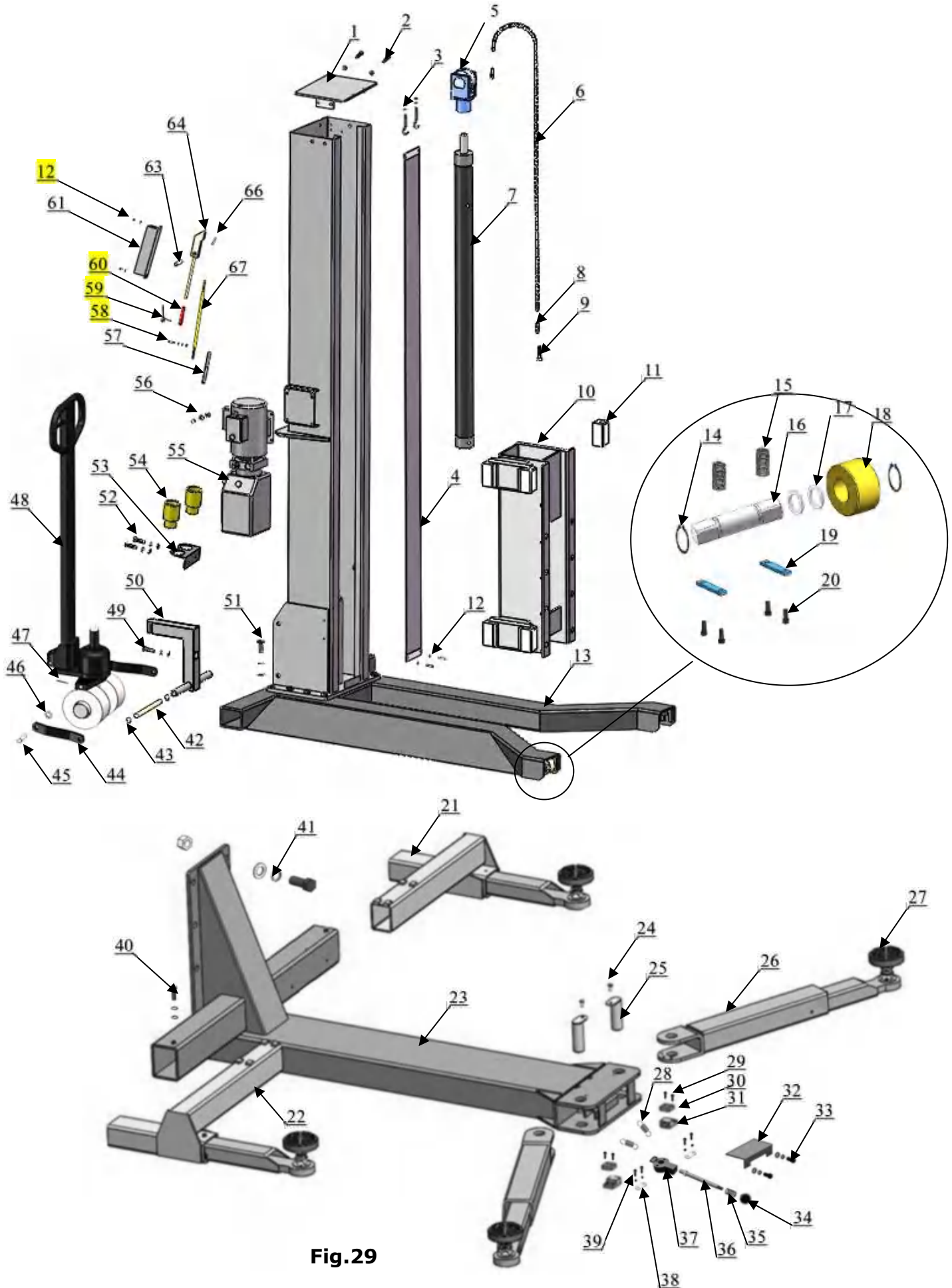

Fig.29

PARTS LIST FOR SML-7

Item	Part#	Description	QTY
1	11101013	Top plate	1
2	1001085013	M12*30 hex bolt w/ M12 nylok nut	2
3	1101085015	Hook bolt M6*95 w/ φ6 flat washer, M6 Nylok Nut	2
4	11101042	Fabric curtain cover L=101 3/16"(2570mm)	1
5	11207681	Chain pulley seat assy.	1
6	10101007	Chain	1
7	10207010	Cylinder	1
8	10201010A	Connector	2
9	10201005	Cotter pin φ4*50	1
10	11102608-01	Carriage	1
11	1002755015	Slider block 2 5/32" x 1 31/32" x 3 15/16" (55*50*100mm)	8
12	1001085016	M6*8 cup head bolt w/ φ6 flat washer	6
13	11102611	Base	1
14	10610008	Clip ring φ30	4
15	10683018	Spring φ18*φ11*70	4
16	11101039	Roller shaft	2
17	41080221	Bearing	4
18	11101038	Wheel	2
19	11101675	Wheel shaft limit block	4
20	10420138	Socket bolt M6*16	8
21	10102028	Inside arm assy. (right)	1
22	10102029	Inside arm assy. (left)	1
23	11102609-01	Platform	1
24	10101003	M8*12 flat head bolt	2
25	11101005	Arm pin	2
26	10101033	Outside arm assy.	2
27	10203054	Rubber pad assy.	4
28	1101015001	Extension spring Φ13*Φ10*Φ1.5*32	2
29	85090128	Socket Bolt M6*20	4
30	10101008	Arm lock	2
31	11101009-01	Arm lock fixing plate	2
32	1101012010	Limit cover plate	1
33	1001045001	M5*12 socket bolt w/ flat washer, lock washer	2
34	10209020	Plastic ball M8	1
35	1101015001	Spring Φ12.6*Φ1.2*21	1
36	1101012009	Arm lock release handle	1
37	1101012004A	Arm lock connecting block	1
38	1101012002	Connector	2
39	1101012008	Limit sleeve Φ10*6.2	4
40	1001045002	M8*20 hex bolt w/ flat washer, lock washer	2

Item	Part#	Description	QTY
41	1001085008	M20*40 hex bolt w/ φ20 flat washer, φ20 lock washer and M20 nut)	8
42	11102010	Dolly connecting pin φ19*376	1
43	10206019	Clip ring φ19	2
44	11101030	Dolly connecting plate	2
45	10101039	Dolly limit pin φ16*49	2
46	10420029	Flat washer φ16	2
47	10101038	Snap Pin φ5*40	2
48	10101028	Dolly cylinder assy.	1
49	1001045003	M12*20 socket bolt w/ flat washer, lock washer	1
50	11102607	Dolly fixing square tube	1
51	1001085005	M20*50 hex bolt w/ φ20 flat washer, φ20 lock washer	10
52	1001045004	M8*12 hex bolt w/ flat washer, lock washer	2
53	11203035	Stackable adapter bracket	1
54	11203034	Stackable adapter 3"	4
55	81513101	Manual power unit 071103	1
56	1001085009	M8*25 hex bolt w/ 8*20*3 black rubber ring, M8 nylok nut	4
57	11203261	Power-side safety block	1
58	1001085014	M6*20 hex bolt w/ φ6 flat washer φ6 lock washer M6 nylok nut	1
59	10209007	Spring 120°	1
60	10206003	Rubber sleeve for safety release handle	1
61	10209008	Safety device cover	1
62	10101037	Steel ball	1
63	11206002	Pin for safety block	1
64	11203263	Safety Device	1
65	11102033-01	Column	1
66	10209012	Snap ring φ3.2	1
67	11203013	Coupling bar	1
68	1001085017	Limit bolt M8*16 w/ lock washer	1
69	10101501	Parts Box	1
70	10101027	Oil hose 1/4"*65 11/32"	1
71	10201090	Shim 3/64" (1mm)	10
72	10620065	Shim 5/64" (2mm)	10
73	10209060	90° fitting for power unit	1

4.1 Rubber pad assy. (10203054) exploded view:

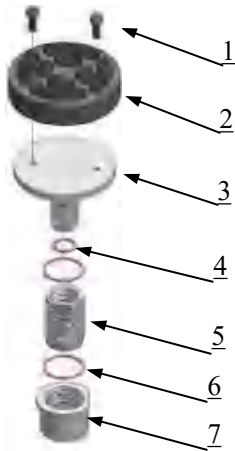

Item	Part#	Description	QTY
1	10420043	M8*20 Socket bolt	8
2	10203043	Double screwed rubber pad	4
3	11203026	Support frame	4
4	10203041	Snap ring	4
5	11203025	Adjusting rod	4
6	10203042	Snap ring	8
7	11203024	Adjusting sleeve	4

Fig.30

4.2 Outside arm assy. (10101033) exploded view:

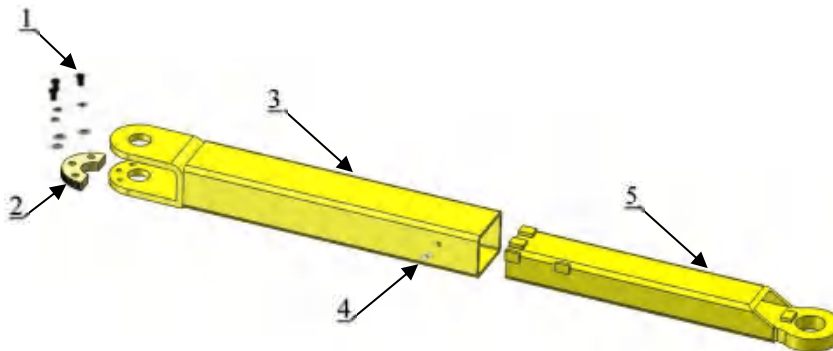

Fig.31

Item	Part#	Description	QTY
1	1001045006	Socket bolt M8*25 (w/ flat washer, lock washer)	6
2	10209035	Moon gear	2
3	11101019	Outer arm	2
4	10201149	Cup head bolt M8*12	2
5	11203101	Inner arm	4

4.3 Inside arm assy. (left) (10102029) exploded view:

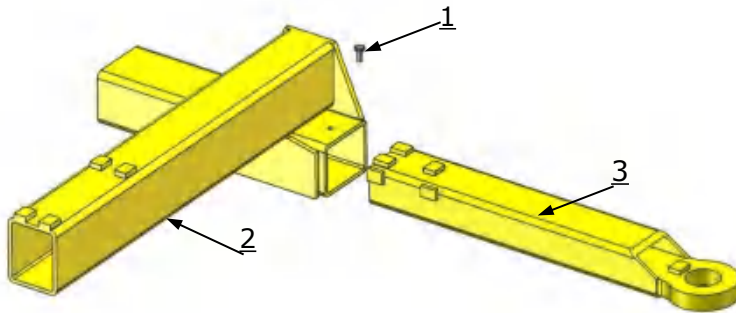

Fig. 32

Item	Part#	Description	QTY.
1	10201149	M8*12 cup head bolt	1
2	11102610	Outer arm	1
3	11203101A	Inner Arm	1

4.4 Inside arm assy. (right) (10102028) exploded view:

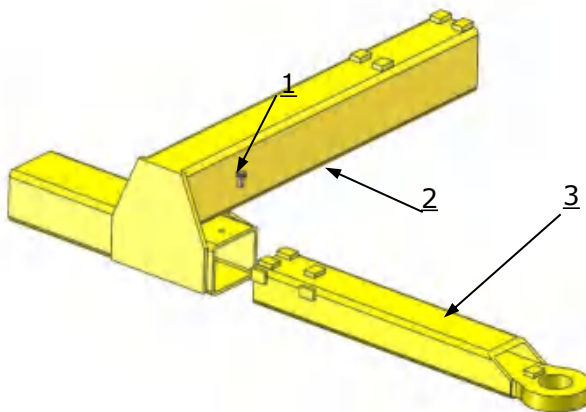

Fig. 33

Item	Part#	Description	QTY.
1	10201149	M8*12 cup Head Bolt	1
2	11102612	Outer arm	1
3	11203101A	Inner Arm	1

4.5 Chain pulley seat assy. (11207681) exploded view:

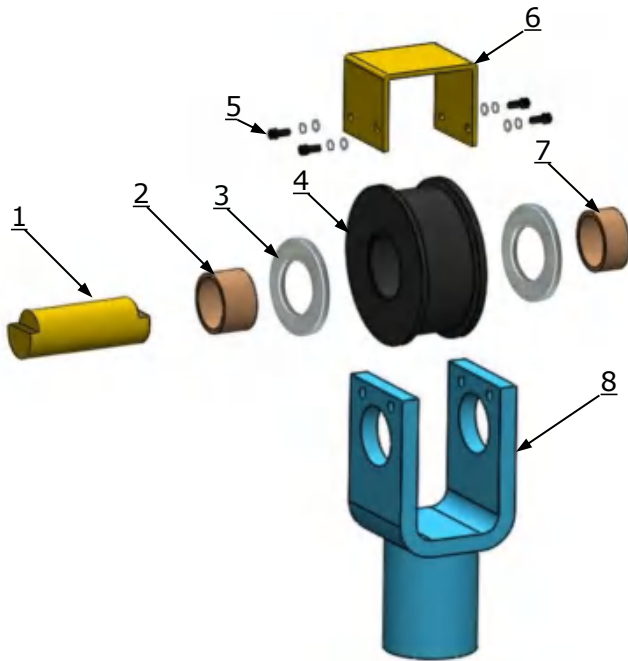

Fig. 34

Item	Part#	Description	QTY.
1	11207006	Pin for Chain Pulley $\Phi 35 \times 93$	1
2	10420132A	Bronze bush $\Phi 41.2 \times \Phi 35.1 \times 20$	1
3	11530023	Flat washer $\Phi 44 \times \Phi 35.5 \times 2$	2
4	11207007	Chain Pulley $\Phi 105 \times 50$	1
5	10430138	M6*15 hex bolt w/ flat washer, lock washer	4
6	11207693	Chain limit block	1
7	10530042	Bronze bush $\Phi 41.2 \times \Phi 35.1 \times 28$	1
8	11207008	Chain pulley seat	1

4.6 Cylinder (10207010) exploded view:

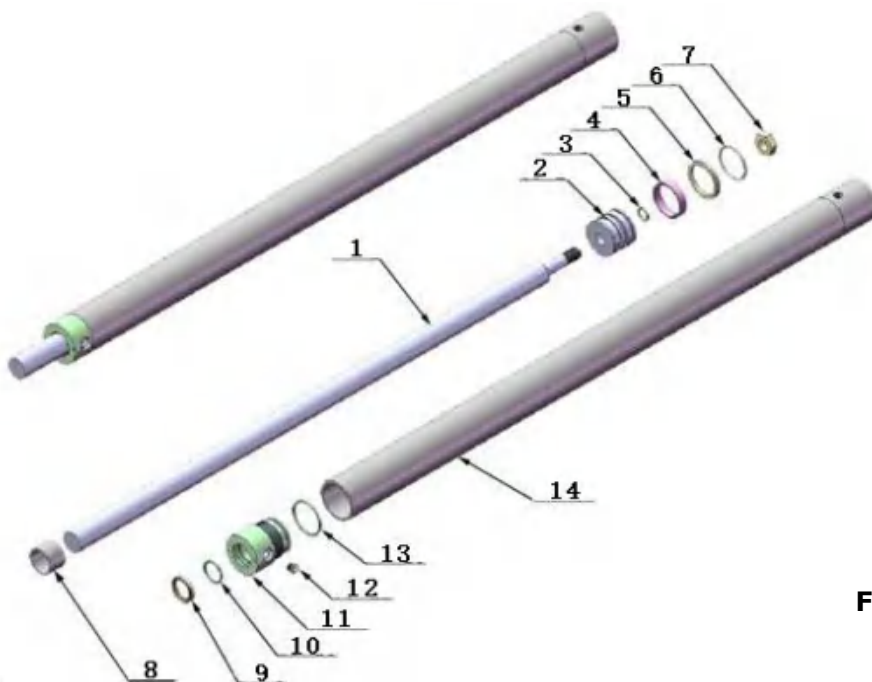

Fig. 35

Item	Part#	Description	QTY.
1	11207027	Piston rod	1
2	11207028	Piston	1
3	10206069	O-Ring	1
4	10620053	Support ring	1
5	10620054	Y-ring OSI	1
6	10630027	O-ring	1
7	10206071	Hex Nut	1
8	11207029	Cylinder adjusting sleeve	1
9	10217078	Dust ring	1
10	10520058	O-ring	1
11	11207030	Head cap	1
12	10201034	Bleeding plug	1
13	10207031	O-ring	1
14	11207032	Bore weldment	1

Illustration of hydraulic valves for power unit

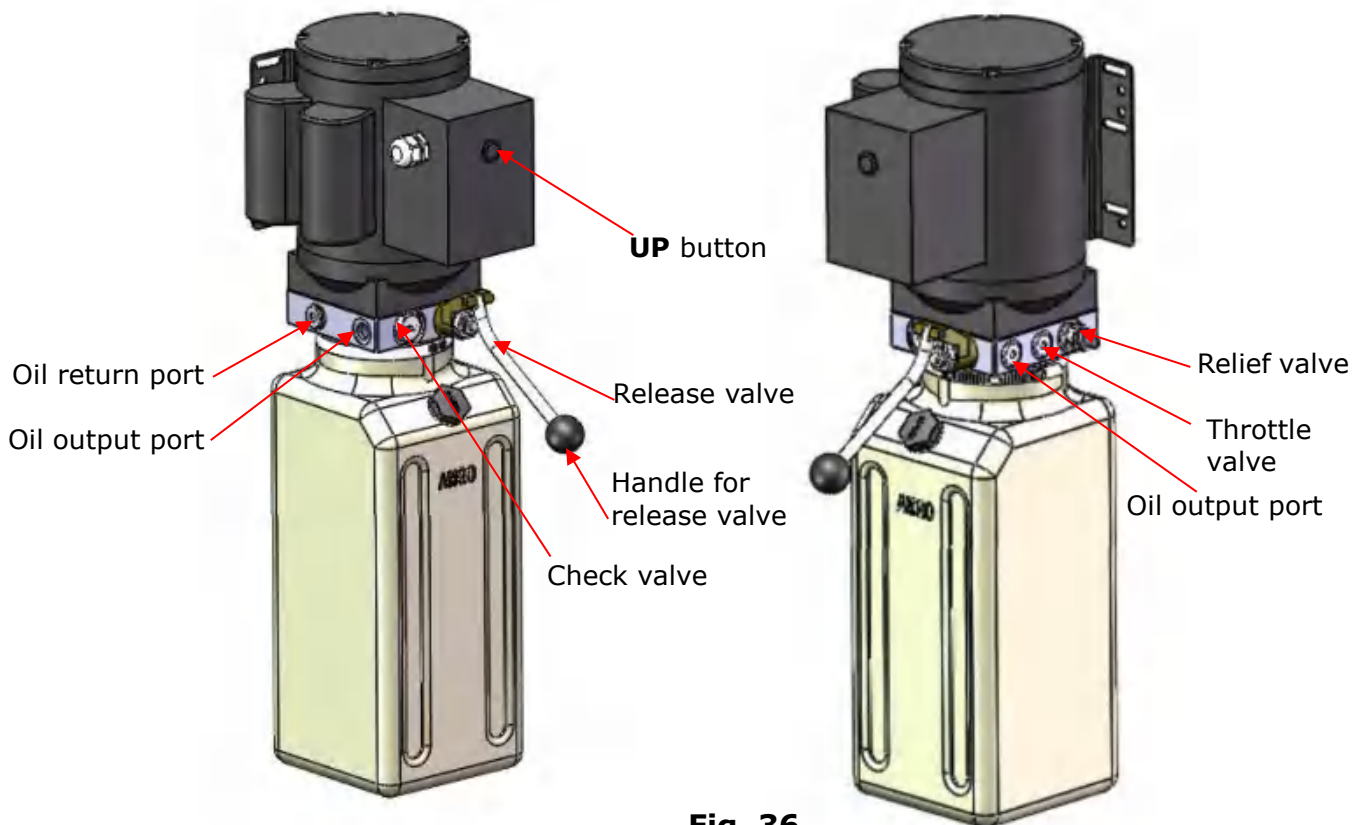

Fig. 36

V. TEST RUN

1. Adjust the lowering speed (Fig.37)

If necessary, you can adjust the lowering speed of the lift by turning the throttle valve clockwise to decrease it, or counterclockwise to increase the lower speed.

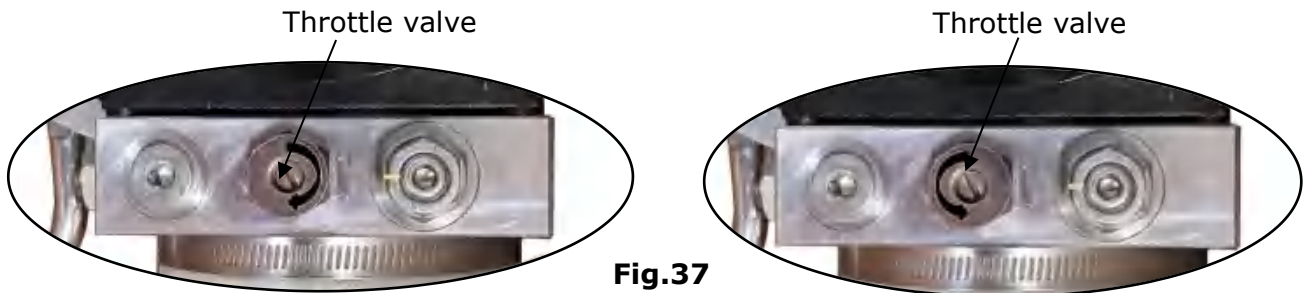

Fig.37

Clockwise to decrease the lowering speed

Counterclockwise to increase lowering speed.

2. Test with load

A test with load should be conducted after the above adjustments have been completed. Run the lift at low level several times first, when there is no other abnormal phenomenon, run the whole process. Repeat the above adjustment if there is any abnormal phenomenon.

Tips: There will be vibration during the first operation without load, load and run several times, the vibration will disappear naturally after the air in the hydraulic system is exhausted!

Hydraulic Schematic Diagram

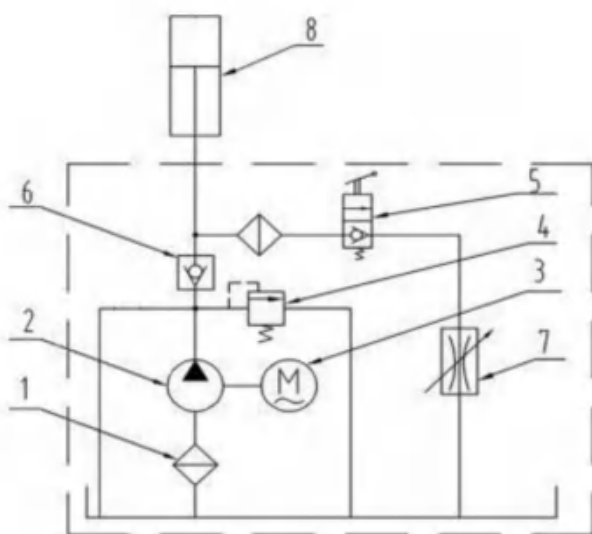

- 1. Filter
- 2. Gear pump
- 3. Motor
- 4. Relief valve
- 5. Release valve
- 6. Check Valve
- 7. Throttle valve
- 8. Cylinder

Fig.38

 **WARNING** Do not lift vehicles that exceed the rated capacity of the lift. Please do not release the safety handle until the lift safety lock is locked. Only trained personnel are authorized to operate the lift.

VI. OPERATION INSTRUCTIONS

To lift vehicle

1. Keep operation site clean;
2. Lower the lifting arm to the lowest position;
3. Retract the lifting arm to the shortest position;
4. Swing lifting arms straight to both sides;
5. Drive the vehicle onto the lift. To get off conveniently, make the cab towards outside instead of the column side;
6. Move arms to the vehicle's lifting point;

Note: The four lift arms must at the same time contact the vehicle's lifting point as recommended by the vehicle manufacturer.

7. Turn on the power switch QS and push the **UP** button until the rubber pads fully contact the vehicle and ensure the safety;
8. Continue to raise the vehicle slowly, ensure the vehicle balance and lift it to the required height, then release the UP button;
9. Press the safety release handle to lower the lift at the safety lock position. Ensure that the safety device is in normal working condition before you carry out maintenance for the vehicle.

To lower vehicle

1. Clear obstructions around and under the lift and keep people away from the lift;
2. Push **UP** button to raise the vehicle slightly to unlock the safety device, press the safety release handle to lower the vehicle;
3. Swing the lifting arms straight to both sides and retract the lifting arms to the shortest;
4. Drive away the vehicle.

 **WARNING** It is unsafe to work when the lift without locking at safety device after it has been raised. The vehicle may fall, potentially causing damage the vehicle and lift, even injury or death to someone nearby.

 **DANGER** When using the lifting points on the chassis recommended by the vehicle manufacturer, be sure to follow the instructions carefully. If you don't, the vehicle can become unstable and fall, which can damage the vehicle and lift, injure or even kill anyone under the vehicle.

VII.MAINTENANCE SCHEDULE

Monthly:

1. Tighten all connecting bolts;
2. Check all fitting, bolts and pins to ensure proper connections;
3. Lubricate slider, chain with lubricant;
4. Make a visual inspection of all hydraulic hoses/lines for possible wear or leakage;
5. Check safety device and make sure in proper condition;
6. Lubricate all rollers and pins with 90Wt gear oil.

Every six months:

1. Make a visual inspection of all moving parts for possible wear, interference or damage;
2. Check equalizer tension and possible wear of the chain;
3. Check column for plumbness;
4. Check rubber pads and replace as necessary;
5. Check safety device and ensure in proper condition;
6. Check hydraulic oil level of power unit;
7. Check the engagement of moon gear and arm lock.

Oil cylinder maintenance:

In order to extend the service life of the oil cylinder, please operate according to the following requirements.

1. Recommend to use N46 anti-wear hydraulic oil;
2. The hydraulic oil of the lifts should be replaced regularly during using. Replace the hydraulic oil 3 months after the first installation and replace the hydraulic oil once a year afterwards;
3. Make at least one full trip raising and lowering per day. This can exhaust the air from the system, which could effectively avoid the corrosion of the cylinder and damage to the seals caused by presence of air or water in the system;
4. Protect the outer surface of the oil cylinder's piston rod from bumping and scratching, and timely clean up the debris on the oil cylinder dust-ring and the piston rod.

VIII. TROUBLE SHOOTING

TROUBLE	CAUSE	REMEDY
Motor does not run	<ol style="list-style-type: none"> 1. Button does not work 2. Wiring connections are not in good condition 3. AC contractor burned out 4. Motor burned out 	<ol style="list-style-type: none"> 1. Replace 2. Repair all wiring connections 3. Replace 4. Repair or replace
Motor runs but the lift is not raised	<ol style="list-style-type: none"> 1. Release valve in damage 2. Gear pump in damage 3. Relief valve or check valve in damage 4. Low oil level 	<ol style="list-style-type: none"> 1. Repair or replace 3. Repair or replace 4. Repair or replace 5. Fill tank
Lift does not stay up	<ol style="list-style-type: none"> 1. Release valve out of work 2. Relief valve or check valve leakage. 3. Cylinder or fittings leaks 	<ol style="list-style-type: none"> 1. Repair or replace 2. Repair or replace 3. Replace seal kit or fittings.
Lift raises too slow	<ol style="list-style-type: none"> 1. Oil system is jammed 2. Motor running on low voltage 3. Oil mixed with air 4. Gear pump leaks 5. Overload lifting 	<ol style="list-style-type: none"> 1. Clean the oil system 2. Check electrical system 3. Fill tank 4. Replace 5. Check load
Lift cannot lower	<ol style="list-style-type: none"> 1. Safety devices are locking 2. Release valve in damage 3. Safety cable is broken 4. Oil system is jammed 	<ol style="list-style-type: none"> 1. Release the safety devices 2. Replace 3. Replace 4. Clean the oil system

IX. CAR LIFT SAFETY TIPS

Post these safety tips in a place where you can always alert the operator. Please reference to the lift manufacturer's manual for specific information about the lift.

1. Check the lift daily. If the machine breaks down or has damaged parts, do not operate, and use the parts of original equipment to repair;
2. Do not overload the lift. The rated weight of the manufacturer design is indicated on the label of the lift;
3. Position control of the vehicle and operation of the lift can only be done by a trained and authorized person;
4. You can not lift a vehicle with people inside. When the lift is working, the customer or other people should not be around the machine;
5. Keep the place around the lift clear of obstacles, lubricants, grease, garbage and other debris for a long time;
6. Before driving the vehicle into the lift, put the lifting arm and rubber pad in the proper position to ensure barrier-free space. Do not hit or run over the lift arm and rubber pad of the lift, otherwise it will cause damage to the lift machine or the vehicle;
7. Raise the lift to the required height for operation. **Note**, if you are working under a vehicle, raise the lift high enough and make sure the safety devices are locked;
8. Note, removing(or installing) parts from a vehicle would cause a sudden shift of gravity that is unstable for the raised vehicle. Reference to the vehicle manufacturer's service manual as a recommended procedure when removing parts from the vehicle;
9. Before lowering the lift , make sure that the tool tray, tool rack, etc. are removed from under the vehicle. Release the lock before lowering the lift;
10. Before removing the vehicle from the lift, put the lifting arm and rubber pad in place to ensure an unobstructed exit.

X. LIFT DISPOSAL

When the car lift cannot meet the requirements for normal use and needs to be disposed, it should follow local laws and regulations.



Address:

SC Division: 1931 Joe Rogers Jr Blvd, Manning, SC 29102, USA

TX Division: 4310 Adler Dr., Suite #200, Dallas, TX 75211, USA

<http://www.amgohyd.com>

Manual No.: **72115209**
Revision Date: **2023.10**