



Original

Installation And Service Manual

Motorcycle Lift Model: MC-1200

Cargo Claims

If there is any missing or damaged product during transportation, the buyer must not sign on the shipping paperwork or refuse the shipment. NOTATE ALL DAMAGE OR REFUSE DAMAGED SHIPMENT!



DANGER

Read the entire contents of this manual before using this product. Failure to follow instructions and safety precautions could result in serious injury or even death. Make sure all other operators also read this manual. Keep this manual near the machine so that it can be seen by all users. By proceeding with installation and operation, you agree that you are fully understand the contents of this manual and take full responsibility for the use of the product.

CONTENTS

PROFILE	1
IMPORTANT SAFETY INSTRUCTIONS	3
I. PRODUCT FEATURES AND SPECIFICATIONS	5
II. INSTALLATION REQUIREMENT	7
III. INSTALLATION STEPS	9
IV. EXPLODED VIEW	14
V. TEST RUN	18
VI. OPERATION INSTRUCTIONS	20
VII. MAINTENANCE SCHEDULE	21
VIII. TROUBLE SHOOTING	22
IX. CAR LIFT SAFETY TIPS	23
X. LIFT DISPOSAL	23

Explanation of the safety warning symbols used in this manual

-  **DANGER** Risk of death or injury
-  **WARNING** Dangerous or unsafe practices that may result in death or injury
-  **CAUTION** Dangerous or unsafe practices that may result in personal injury, product damage or property damage
- ATTENTION** Conditions that may result in damage to products or property

PROFILE

This instruction manual is specially prepared for you. Your new lift is the product of over a decade of continuous research, testing and development and is the most technologically advanced lift on the market today.

Please make sure to read through this manual before operating the lift.

Record the information on the nameplate label here:

Model No.: _____

Serial No.: _____

Manufacturer date: _____

WARRANTY

The warranty period for the steel structure part of new car lift is 5 years, hydraulic components, bronze bushings, sliders and plastic parts are under warranty for 3 years, and electrical components and sync cable, lock release cable warranty for 2 years. Rubber pads are without warranty. During the warranty period, the manufacturer will repair or replace the defective parts free of charge including shipping costs.

This warranty does not cover damage caused by normal wear and tear, improper use, damage in transit, or damage caused by lack of maintenance.

This warranty is unique and supersedes what is expressed and implied in all other warranties. The manufacturer shall not be liable for any particular, indirect or accidental damage resulting in breach of or delay in the execution of the warranty. The manufacturer reserves the right to design and improve the product and has no obligation to make notice of the changes in advance.

The product warranty based on the above clause is based on the model number and serial number of the equipment. This information must be provided in conjunction with all warranty information at the time of service and warranty.

SAFETY WARNING LABEL



Fig.1

IMPORTANT SAFETY INSTRUCTIONS

In order to properly maintain your product and ensure operator safety, it is the responsibility of the product owner to read and follow these instructions!

1. Ensure product installation complies with all applicable local regulations and rules, such as Occupational Safety and Health Administration regulations and electrical codes.
2. Ensure that all operators are properly trained, know how to operate the unit safely, and are properly supervised.
3. Do not operate the lift until you are sure all parts are in place and operating correctly.
4. Keep your hands and feet away from the machine. Keep hands and feet away from any moving parts. Keep your feet away from the lift as it descends to avoid pressing on pointed objects.
5. Keep the work area clean. A cluttered workspace can lead to injuries.
6. The machine is only approved for indoor installation and use. Outdoor installation is prohibited.
7. Only trained operators are allowed to handle the lift machine. All untrained persons must stay away from the workplace. Never allow untrained persons to handle or operate the machine.
8. Use the lift properly. Use the lift in the correct way.
9. Warning! Keep persons and objects from the lift when lifting the a vehicle.
10. If the vehicle is at risk of falling, make sure no one is around the lift.
11. Before preparing to approach or service the vehicle, ensure that the safety device is in effect.
12. Dress appropriately when operating machines, and consider wearing non-slip steel-toe shoes for added safety..
13. Beware of electric shock. In order to protect the operator from electric shock, the lift in use must be grounded. Do not connect the green wire to the terminal. This is the ground wire.
14. Danger! The power supply used in this type of lift has high voltage. Please disconnect the power supply before any circuit repair. Unplug in case the power supply is accidentally switched on during maintenance.
15. Warning! There is a risk of explosion. There are parts in the equipment that produce arc light and spark. Do not operate near flammable gas. This machine should not be placed in

the lounge or basement.

16. Maintain with care. Keep the machine clean for better and safer operation. Perform proper lubrication and maintenance procedures according to the manual. Keep handles or buttons clean, dry, and free of oil.
17. Stay alert. Use common sense to observe what you are doing and stay alert.
18. Check for damaged parts. Check for adjustments to moving parts, damage to parts, or anything that may affect their operation. Do not use the machine if the parts are damaged.
19. Do not remove relevant safety parts from the machine. Do not use a lift if it is damaged or missing.
20. Only operate the lift at temperature between 5°C to 40°C (41°F to 104°F).

 **DANGER** Be very careful when installing, operating, maintaining or repairing this equipment. Failure to comply may result in property damage, product damage, injury or (in very rare cases) death. Ensure that only authorized personnel operate the equipment. All repairs must be carried out by an authorized technician. Do not modify the machine, this voids the warranty and increases the probability of personal injury or property damage. Ensure to read and follow this instructions on the label.

I. PRODUCT FEATURES AND SPECIFICATIONS (See Fig.2)

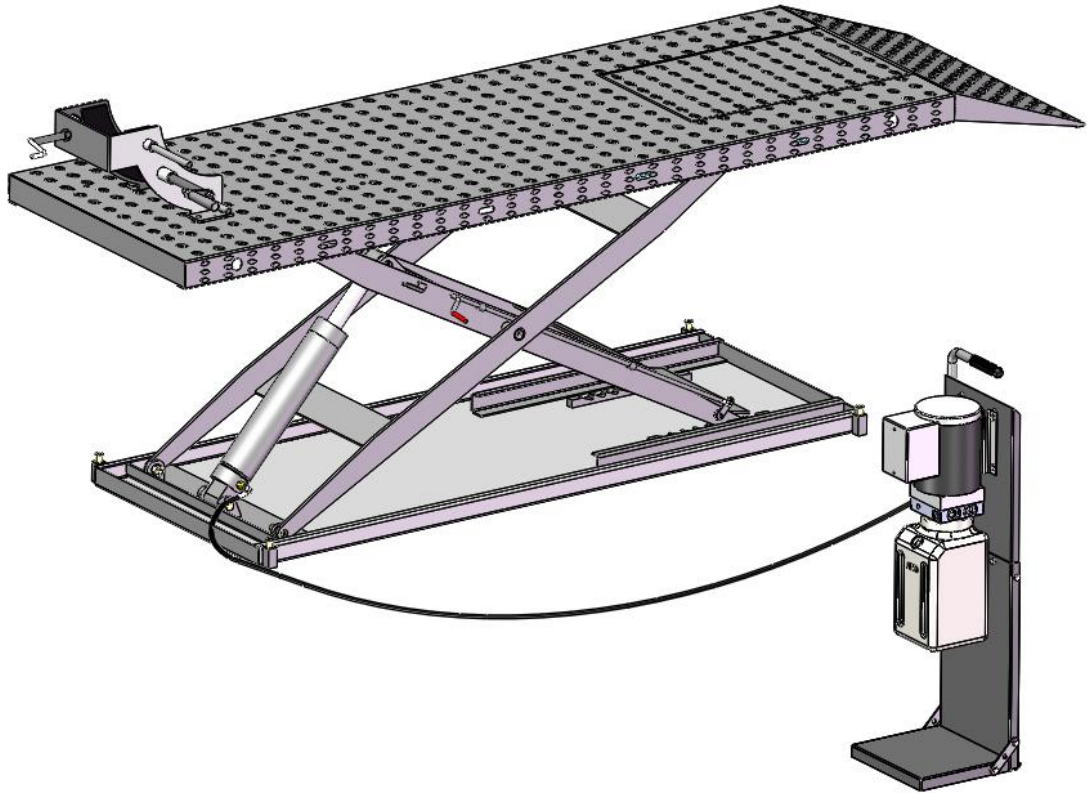

Fig .2

FEATURES OF MODEL MC-1200:

- Hydraulic cylinders, designed and made by USA standard, utilizing oil seal in cylinder.
- Self-lubricating UHMW Polyethylene sliders and bronze bush.
- Non-skid diamond platforms.
- Automatic safety release system.
- Optional: Width extension kit and length extension kit

MODEL MC-1200 DIMENSION AND SPECIFICATION

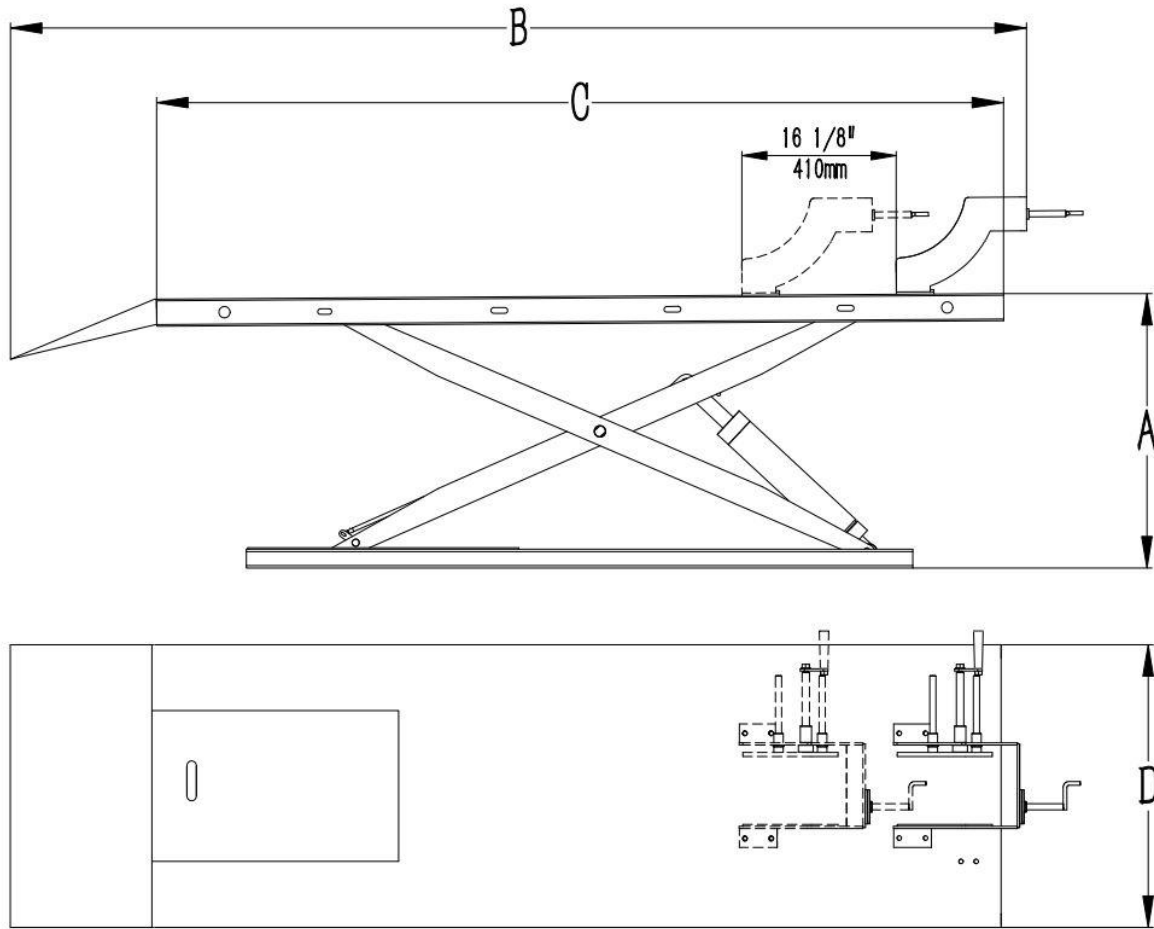

Fig .3

Model	Capacity	Lifting Time	Lifting Height	Max Lock Height	Overall Length	Runway Length	Overall Width	Minimum Height	Motor
MC-1200	1200lbs	23s	42 29/32" (1090mm)	40 9/16" (1030mm)	106 5/16" (2700mm)	88 19/32" (2250mm)	29 17/32" (750mm)	6 3/32" (155mm)	1.0HP

II. INSTALLATION REQUIREMENT

A. TOOLS REQUIRED

✓Rotary Hammer Drill (Φ10)



✓Screw



✓English Spanner (12")



✓Wrench Set: (13#, 15#, 17#, 19#)



✓Ratchet Spanner with Socket: (28#)



✓Pliers



Fig.4

B. Equipment storage and installation requirements.

- 1 . Store the equipment in a dry, non-moldy, non-flammable environment.
- 2 . The lift is only approved for indoor installation and use, and outdoor installation is prohibited.
- 3 . When installing the device, take safety precautions according to the instructions to avoid device damage.
- 4 . Do not install the equipment outside if the installation area is without protection.
- 5 . During installation, all parts should be fastened to ensure the stability and smooth operation of the machine.
6. After installation, the whole machine should be checked to make sure that every component is working properly.

C. SPECIFICATIONS OF CONCRETE

Specifications of concrete must be adhered to the specifications as following.

Failure to do so may result in lift and/or vehicle falling.

1. Concrete must be thickness 4" minimum and without reinforcing steel bars , and must be dried completely before the installation.
2. Concrete must be in good condition and must be of test strength 3,000 psi (210kg/cm²) minimum. Solidify at least 15 days.
3. Floors must be level and no cracks. The two pits for flush-mount installation should be at the same level.
4. Do not install the equipment on asphalt or any surface other than concrete

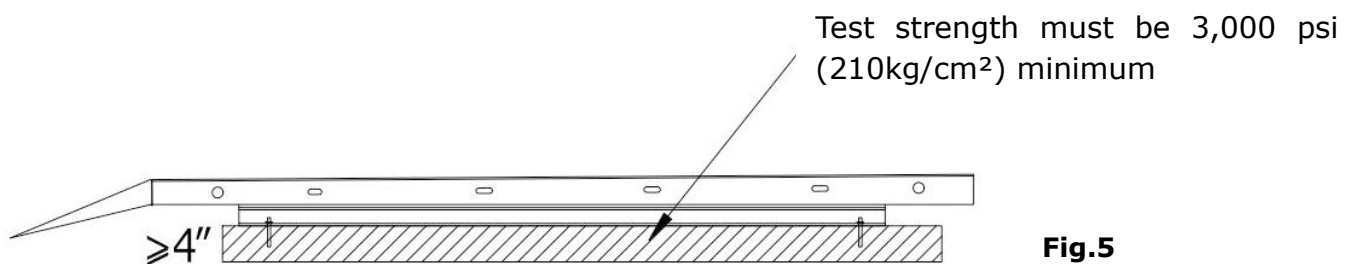

D. POWER SUPPLY

1. You are required to use a licensed and qualified electrician for the installation process.
- 2.The power supply capacity must be 110VAC 60HZ, with a cord larger than 12AWG, and must be properly grounded.

⚠ DANGER All electrical wiring must be performed by a licensed and certified electrician. Attempting to connect the circuit without proper certification may result in damage to the lift or electrocution, resulting in serious injury or death.

III. INSTALLATION STEPS

A. Check the parts before assembly to make sure all the parts are completed.

1. Packaged cargo (lift, drive-in ramp, power unit, power unit stand, wheel vise). Move the parts aside, open the outer packing and check the parts according to the shipment parts list. **see Fig.6**

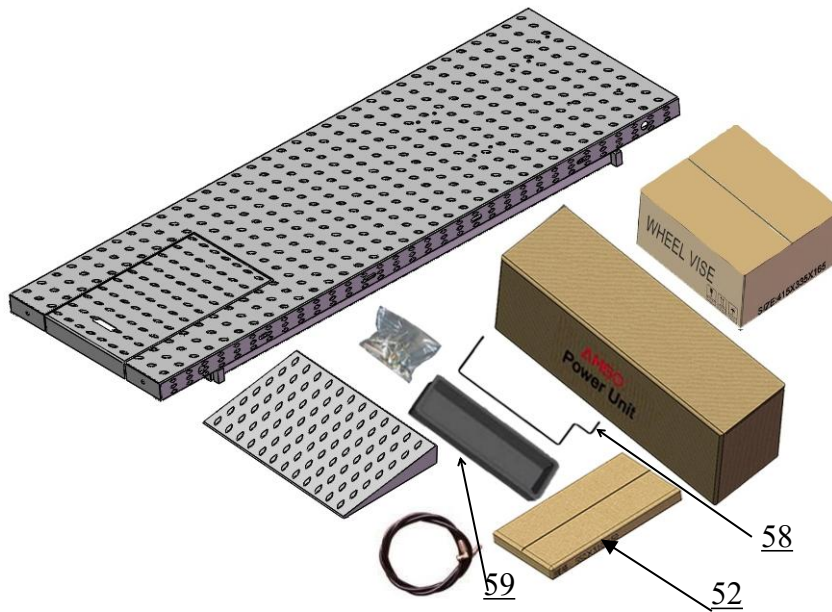

Fig.6

2. Open the parts box, check the parts according to the parts list (**See Fig. 7**).



Fig.7

3. Open the carton and check the parts of power unit stand according to the image below. **(See Fig. 8).**

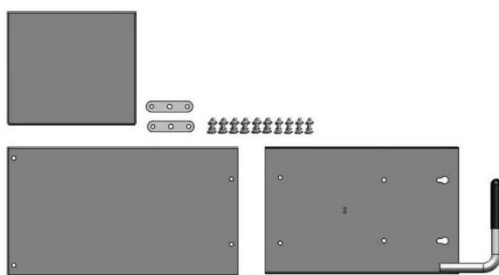
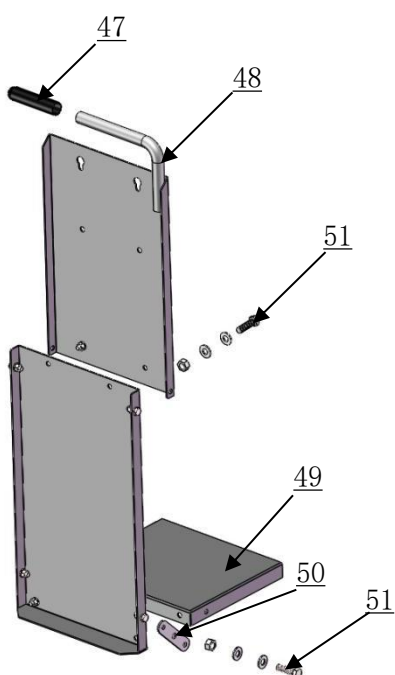

Fig.8

B.Install power unit

1. Install power unit stand.



(Use M8*20 Hex bolt,flat washer,lock washer,nuts for installation)

Fig.9

2. Install power unit

(Use M8*25 Hex bolt,φ20*φ8*3 plastic ring, M8 Nylock,nuts for installation)

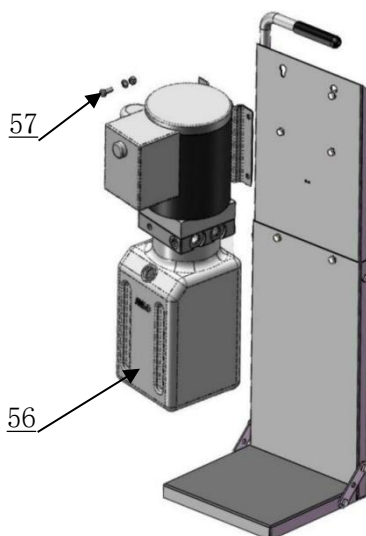

Fig.10

C. Place the lift and control cabinet to the installation site, connect the oil hose and tighten the fitting (see Fig.11)

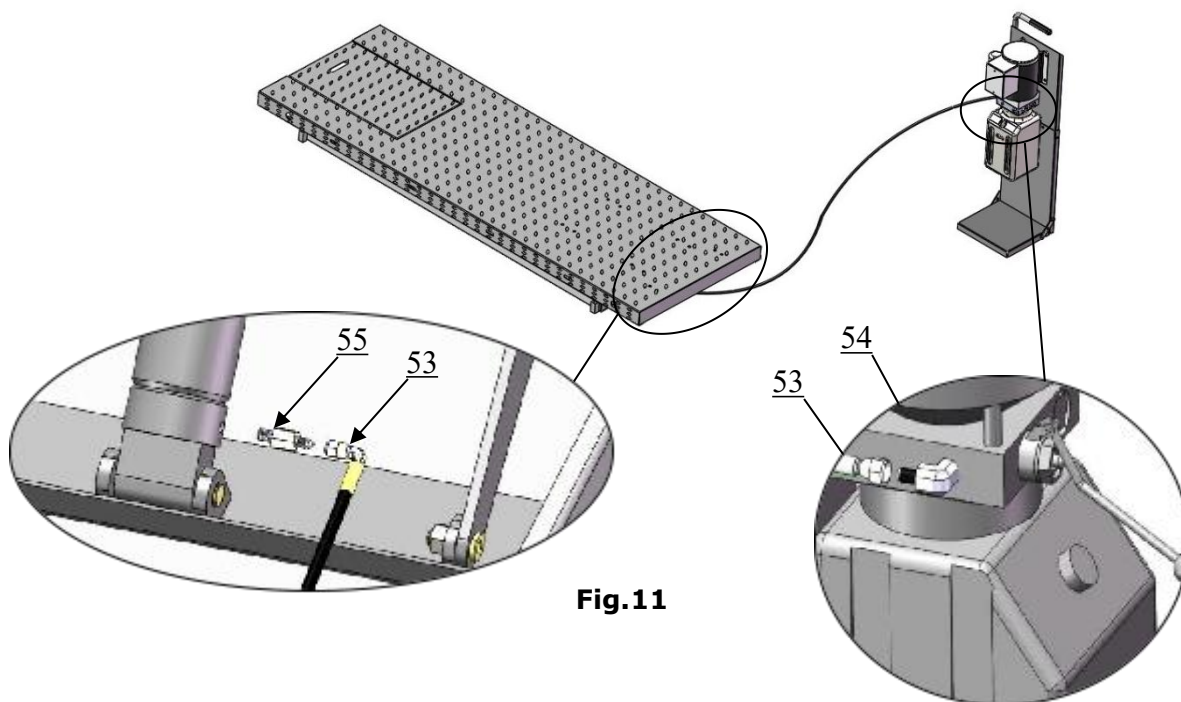

Fig.11

D. Connect the wire according to below diagram.

Single phase motor (Fig.12)

Connecting the two power supply wires to terminals of AC contactor marked L1, L3 respectively. The ground wire is connected to the ground wire terminal. **(Wire instruction inside the box)**

Power supply wires

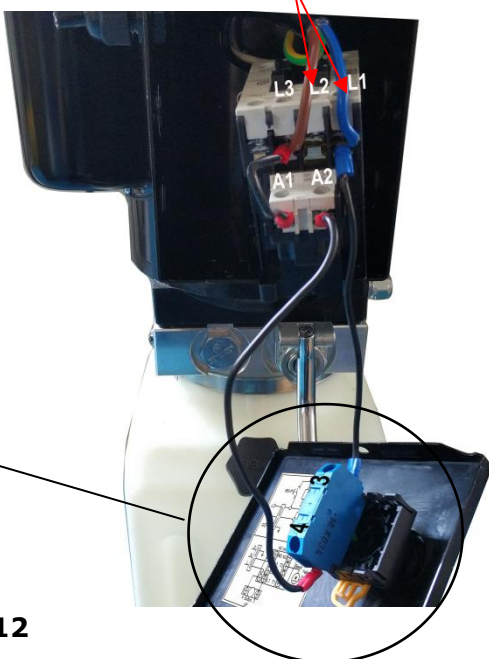
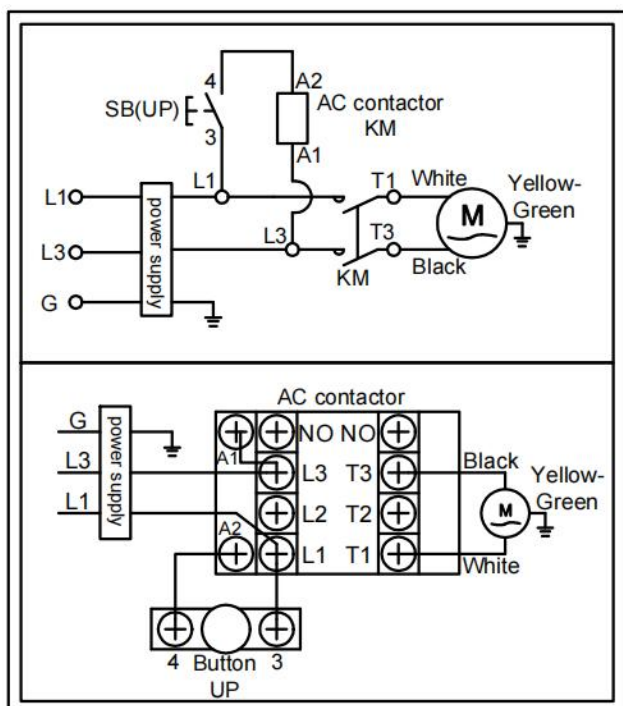

Fig.12

⚠ DANGER All electrical wiring must be performed by a licensed and certified electrician. Before ensuring the main power has disconnected from the lift and cannot be re-applied until all procedures have been completed, do not perform any maintenance or installation to the lift.

F.Fill the power unit with right amount hydraulic oil (In order to ensure the service life of the hydraulic system and keep the lift in best performance, please fill No.46 high-quality anti-wear hydraulic oil.)

E. Install adjustable wheel vise.

1.The wheel vise can be installed in two positions on the platform, allowing users to choose their preferred installation position.(See Fig 13)

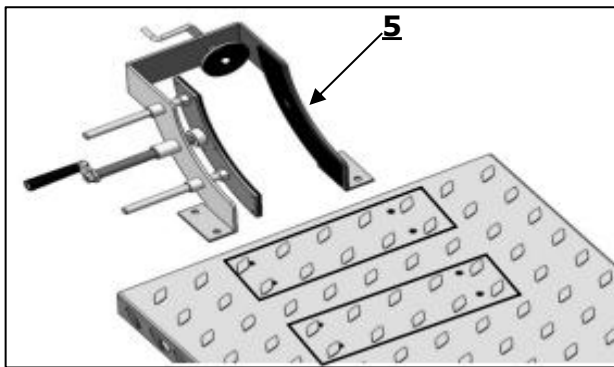

Fig.13

2.Lifting the motorcycle lift to a suitable height, install the wheel vise as to below picture. (See Fig 14)

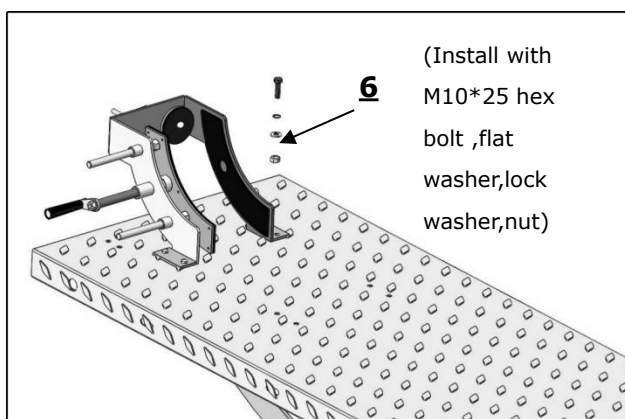

Fig.14

3.Exploded view of wheel vise (See Fig 15)

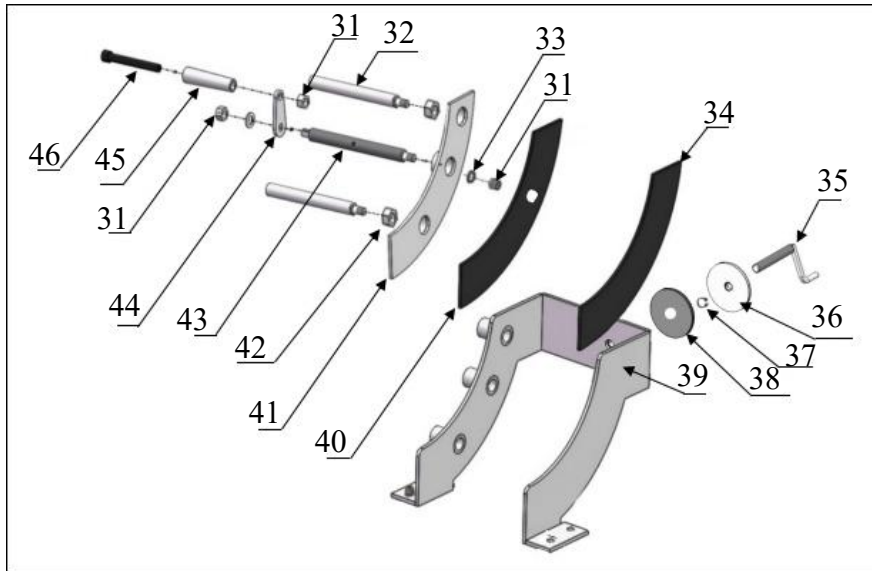

Fig.15

G. Install Optional Width Extension Kit(MC001). See Fig.16

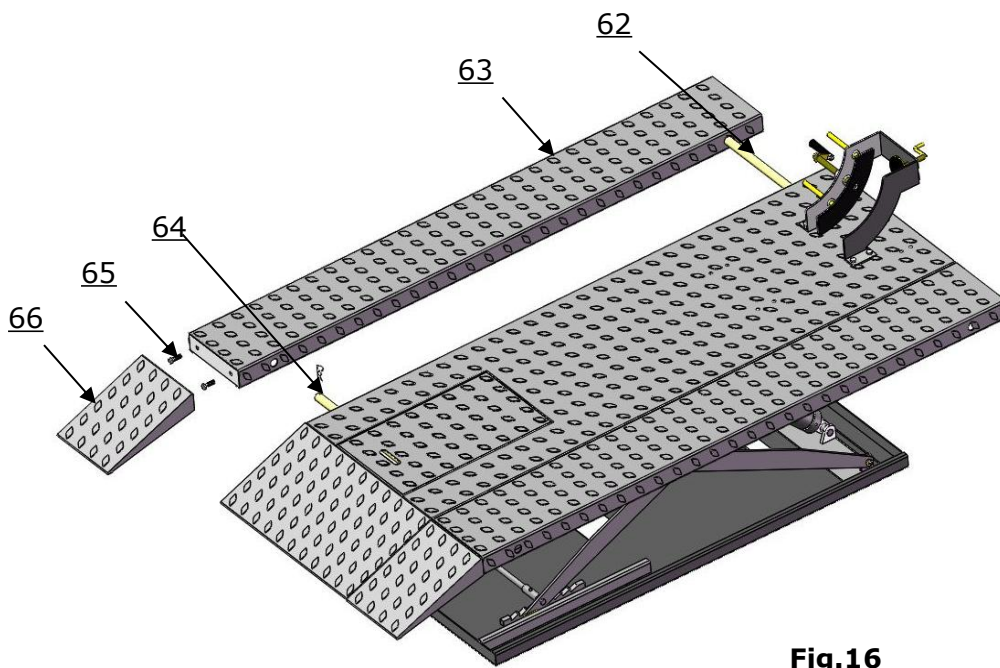

Fig.16

H. Install Optional Length Extension Kit (MC002) . See Fig 17

Note: Connect the length extension kit to one of the wheel vise install holes on the platform.
Move the wheel vise to extension platform.

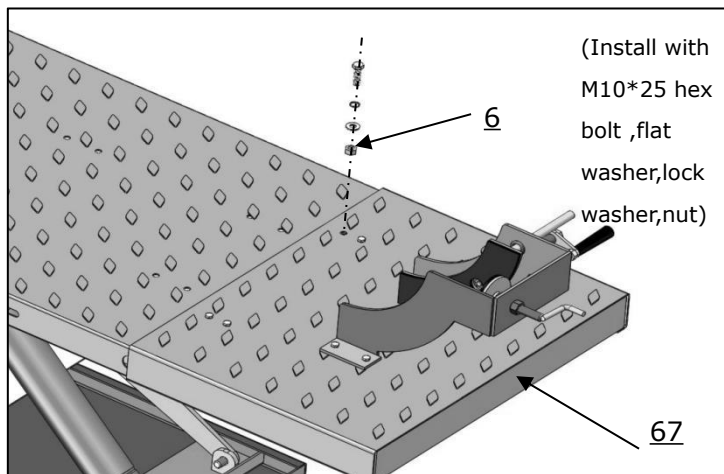

Fig.17

IV. EXPLODED VIEW

MODEL: MC-1200

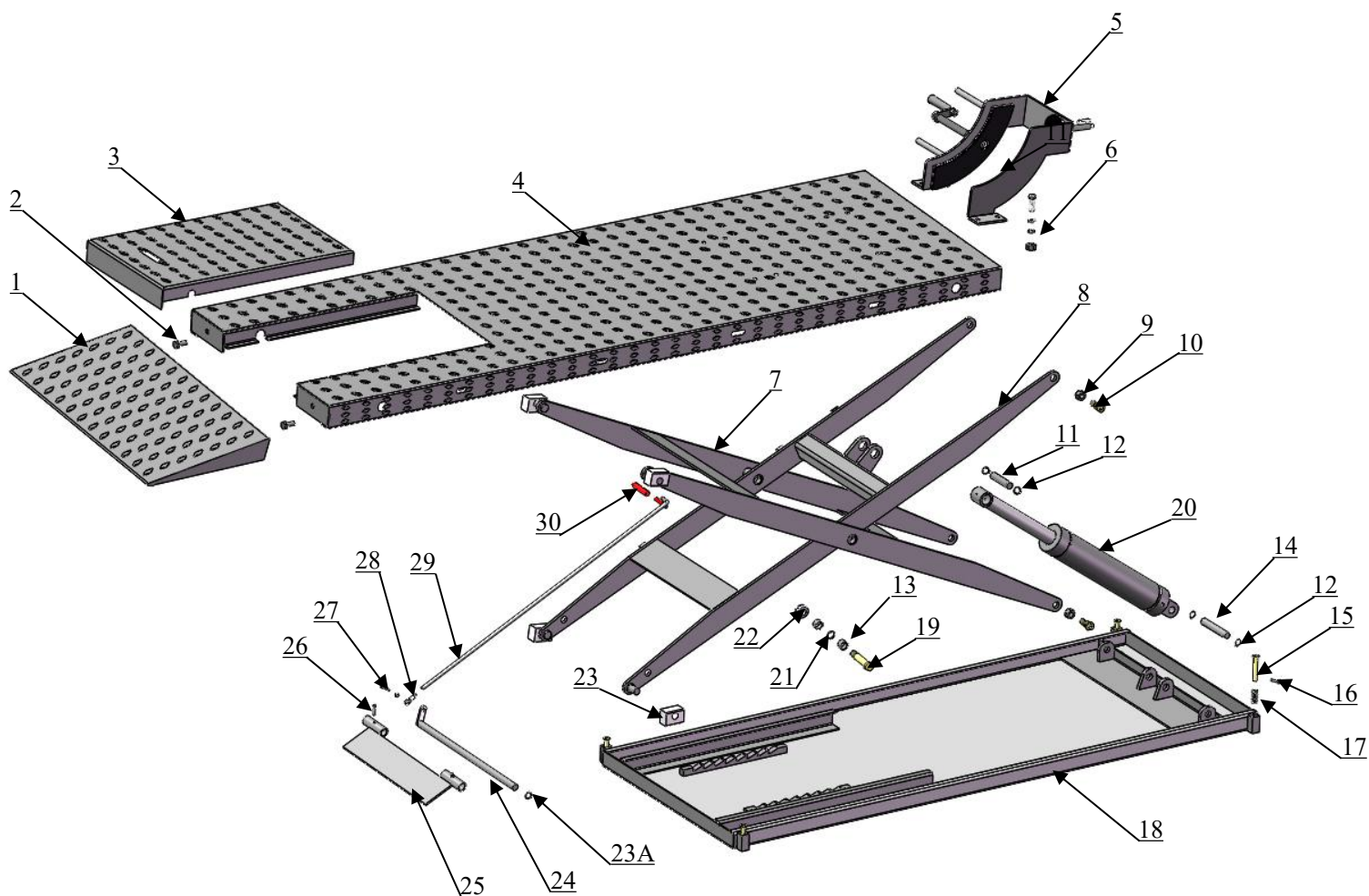

Fig.18

Parts list of Lift

Item	Part#	Description	QTY.	Note
1	11720022	Drive-in ramp	1	
2	10217069	Hex bolt M12*30	2	
3	11720723	Cover plate of platform	1	
4	11720020-01	Platform	1	
5	86010782	Wheel vise assy.	1	
6	1003085008	M10*25 Hex bolt (with flat washer,lock washer,nut)	8	
7	11720023-01	Outer scissor	1	
8	11720024-01	Inner scissor	1	
9	10650024	Nylok nut M16	4	
10	1103082011A	Pins assembly	1	
11	11640057-01	Pin for cylinder connecting	1	
12	10206032	Clip ring φ25	4	
13	1002011001	Steel bush φ22* φ 19*14	4	
14	11640006A	Cylinder base pin φ 25*112	1	
15	11720012A-01	Pin for spring	4	
16	10209025	Snap pin φ4*25	4	
17	10720003	Spring φ 2*75	4	
18	11720027-03	Base	1	
19	1103082006-01	Pin for scissors φ19*87	2	
20	10640007	Cylinder φ63* 290	1	
21	10510053	Washers Φ24*Φ19 .5*1 .8	2	
22	1003085004	Nylok nut M18	2	
23	1003105001	Slider 60*42*33	4	
23A	10206019	Clip ring φ 19	1	
24	11720122	Pin for safety device	1	
25	11720026-01	Safety device	1	
26	10640050	Socket bolt M6*10	2	
27	1003085009	M6*18 socket bolt (with M6 Nylok nut)	1	
28	11720110	Connecting sleeve	1	
29	11720111-01	Connecting pin for safety lock	1	
30	10620136	Rubber tube	1	

Item	Part#	Description	QTY.	Note
31	10206023	Nylok nut M12	3	
32	1103083009	Guide pillar	2	
33	10206006	Washer φ 12	6	
34	1103083011	Support plate (Left)	1	
35	1103083022	Positioning adjustment screw rod	1	
36	1103083019	Positioning plate	1	
37	10630032	Clip ring φ 12	1	
38	1003083002	Rubber pad 90*90* 5	1	
39	1103083015	Wheel vise fixing seat	1	
40	1103083010	Support plate (Right)	1	
41	1103083016	Wheel vise moving board	1	
42	10209066	Hex nut M16	2	
43	1103083012	Adjusting pin	1	
44	1103083007	Handle connecting board	1	
45	1103083017	Control handle	1	
46	10410040	Socket Bolt M12*110	1	
47	10640126	Rubber tube of handle	1	
48	1103334010A	Power unit stand plate	1	
49	1103334011	Base Plate	1	
50	1102022004-01	Fixing Bracket	2	
51	1004574011	Hex Nut M8*20	10	
52	1103085002C	Power unit stand plate ASSY.	1	
53	10440042	Oil Hose assy. 1/4*2550mm	1	
54	10209060	900 Fitting 3/8SAE0/R (M)*1/4JIC(M)	1	
55	10209064	Straight fitting 1/4NPT(M)*1/4NPT(M)	1	
56	071103	Power unit(110V)	1	
57	1001085009	Hex Bolt M8*25	4	
58	11720100	Tool tray bracket	1	
59	10206156	Tool tray	1	
60	10620071	Floor Anchors	4	
Optional:				
61	10720014	Securing belt (Optional)	1	
Optional: Width extension kits (MC001)				

62	11720036-01	Connecting pin	2	
63	10720035-01	Width extension platform	2	
64	11209012	Snap pin ϕ 3.2	4	
65	10217069	Hex bolt M12*30	4	
65	11720034	Width extension drive- in ramp	2	
Optional: Length Extension kits (MC002)				
67	11720062	Extension platform	1	

4.2 Cylinder (10640007)

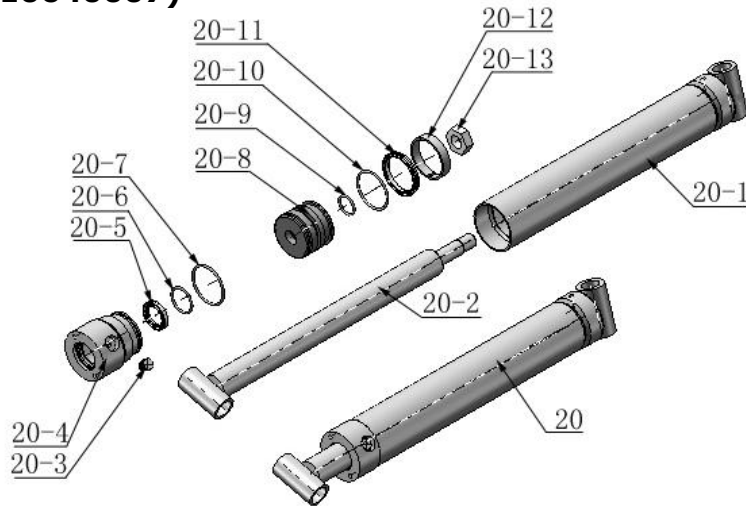

Fig.19

Parts for cylinder

Item	Part#	Description	QTY.	Note
20-1	11640030A	Bore Weldment	1	
20-2	11640031A	Piston Rod	1	
20-3	10201034	Bleeding Plug	1	
20-4	11201033	Head Cup	1	
20-5	10209078	Dust seal	1	
20-6	10201032	O Ring	1	
20-7	10201035	O Ring	1	
20-8	11201028	Piston	1	
20-9	10206069	O Ring	1	
20-10	10201031	O Ring	1	
20-11	10201030-01	Y Ring USH	1	
20-12	10201029	Support Ring	1	
20-13	10206071	Nut	1	
20-14	10620064	Greasing Fitting	2	

Illustration of hydraulic valve for electric power unit (220V/50HZ/1 phase)

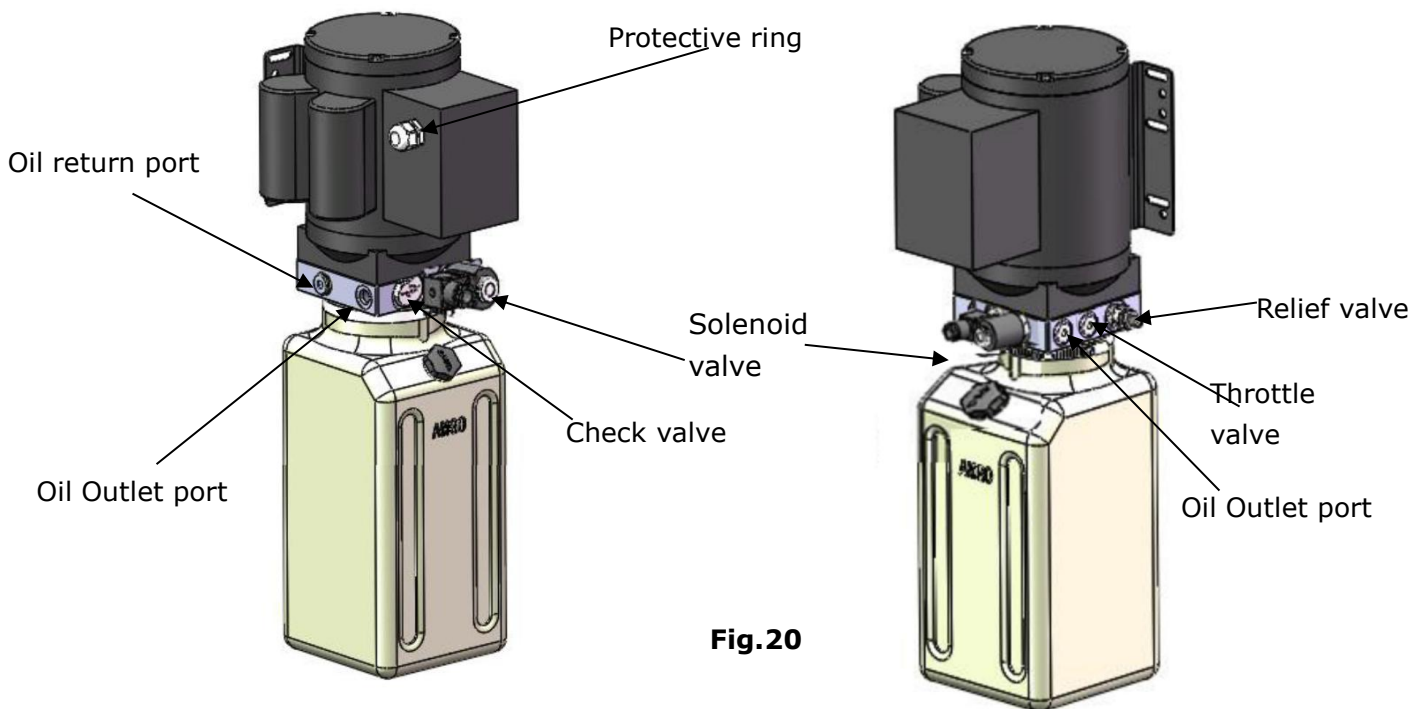

Fig.20

V. TEST RUN

1. Install anchor bolts. (see Fig.21)

Install the anchor bolts to fix the machine after installing.

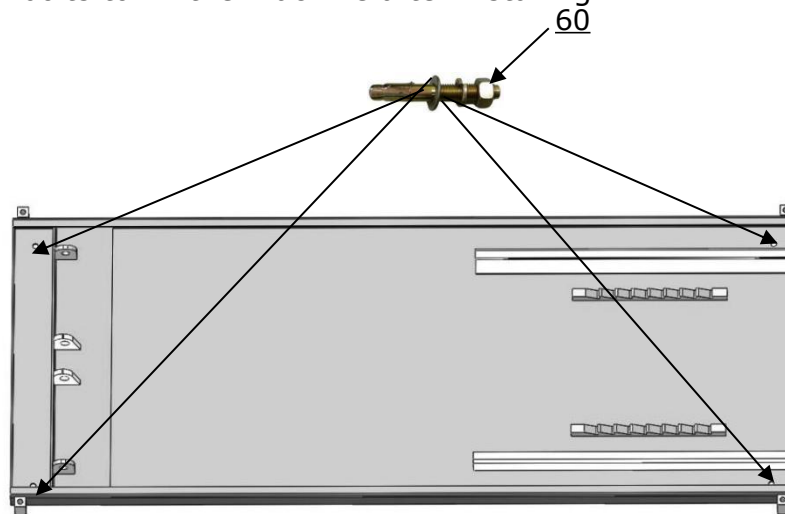

Fig.21

Note: Twisting force is 30N.m for fixing the anchor bolt, knock the anchor bolt into the ground at least 70mm.

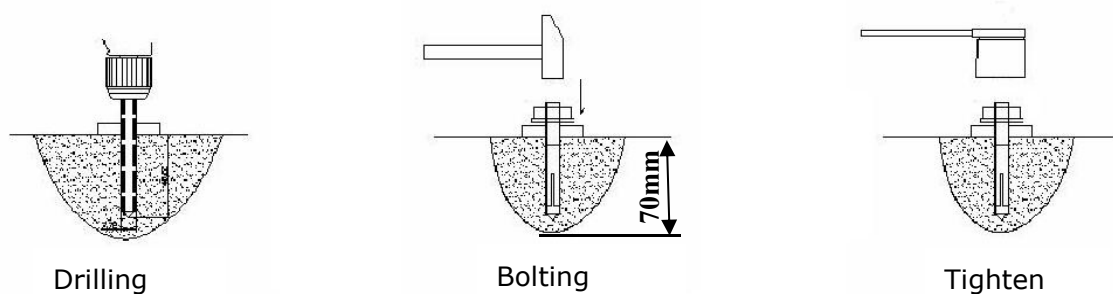

Fig.22

⚠️ WARNING Don't lift vehicles over the rated capacity of the lift. Please Don't leave the lever until the safety lock of the lift is locked. Only trained personnel can raise and lower the lift.

2. Adjust height of safety device

Rise the lift to the highest position (**See Fig.23**), rotating the safety lock handle according to the direction of arrow. Loosen the screw of the safety device by spanner, lift up the safety lock plate from the rack about 15-20mm (**See Fig.24**), then tighten the fixing screw by spanner.

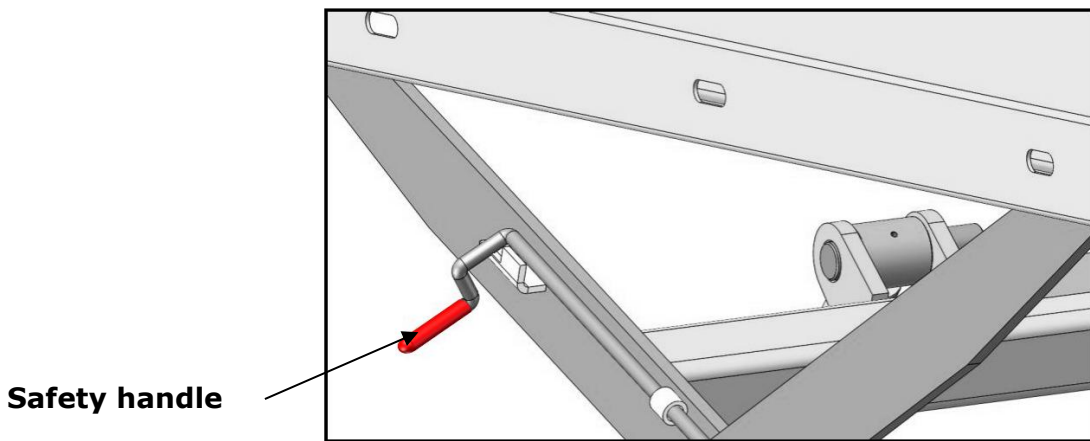

Fig.23

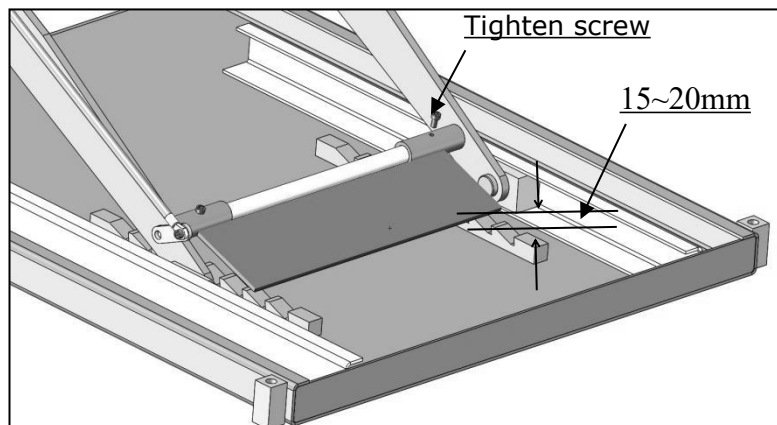

Fig.24

VI. OPERATION INSTRUCTIONS

1. Install well the oil hose between cylinder and power unit, connected the wire, the motorcycle lift can be operated.

2. Rise up the lift without motorcycle for testing.

3. To lift motorcycle

Lower the lift to the lowest position, loosen the wheel vise. Move the motorcycle to the platform, put the front wheel into the wheel vise, set well the motorcycle. Put up the foot stool of the motorcycle. Rotated handle to clamp the wheel. Tighten the securing belt. Make sure the wheel is tightened and the securing belt is fixed before using. (See Fig.25)

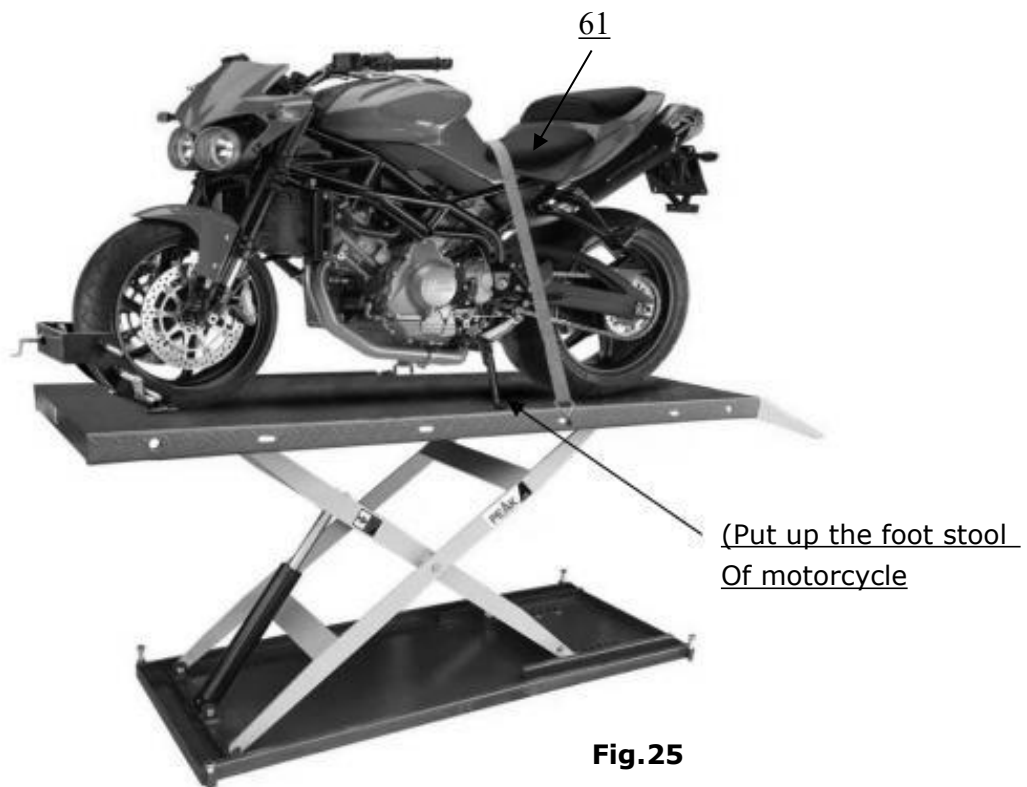

4. To lower the lift: Rise the lift few seconds. Rotate the safety lock handle downward (**see Fig.26**) to release the safety device. After the safety device is released (**see Fig.27**), press **DOWN** button to lower the lift.

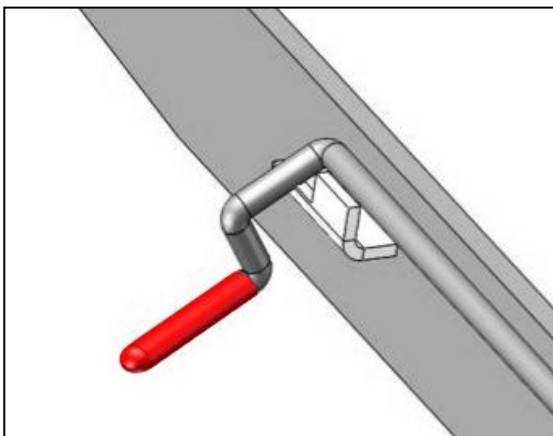

Fig.26

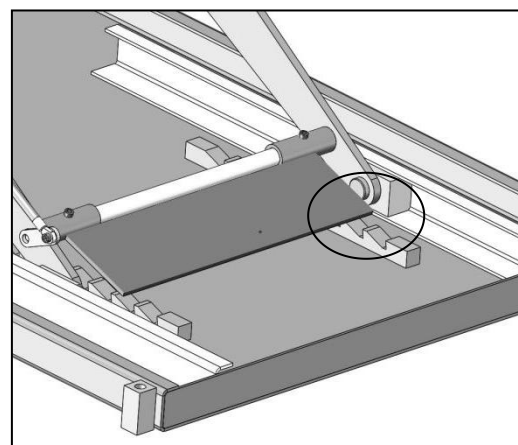

Fig.27

⚠️WARNING It is unsafe to work under the lift without locking at the safety device after it has been lifted up, which may causes vehicle fall, damage, lift damage, human injury or even death.

VII.MAINTENANCE SCHEDULE

Monthly maintenance:

1. Check all connectors, bolts and pins to insure proper mounting.
2. Make a visual inspection of all hydraulic hoses/lines for possible wear or leakage.

Every six months:

1. Make a visual inspection of all moving parts for possible wear, interference or damage.
2. Check all fasteners and re-torque
3. Check whether the safety protection device is in normal working condition
4. Check whether the oil level of the hydraulic station is normal.

Oil cylinder maintenance:

In order to extend the service life of the oil cylinder, please operate according to the following requirements.

1. Recommend to use N46 anti-wear hydraulic oil.
2. The hydraulic oil of the lifts should be replaced regularly during using. Replace the hydraulic oil 3 months after the first installation, Replace the hydraulic oil once a year afterwards.
3. Make at least one full trip raising and lowering per day. For exhausting the air from the system, which could effectively avoid the corrosion of the cylinder and damage to the seals caused by presence of air or water in the system.
4. Protect the outer surface of the oil cylinder's piston rod from bumping and scratching, and timely clean up the debris on the oil cylinder dust-ring and the piston rod.

VIII.TROUBLE SHOOTING

NO	TROUBLE	CAUSE	REMEDY
1	Motor does not run	<ol style="list-style-type: none"> 1. Button does not work 2. Wiring connections are not in good condition 3. Motor burned out 4. AC contactor burned out 	<ol style="list-style-type: none"> 1. Replace button 2. Repair all wiring connections 3. Repair or replace motor 4. Replace AC Contactor
		<ol style="list-style-type: none"> 1. Release Valve in damage 2. Gear Pump out of operation 3. Relief Valve or Check Valve in damage 4. Low oil level 5. Overload lifting or low pressure 	<ol style="list-style-type: none"> 1. Repair or replace 2. Repair or replace 3. Repair or replace 4. Fill tank 5. Check load or adjust the pressure
3	Lift does not stay up	<ol style="list-style-type: none"> 1. Release Valve out of work 2. Relief valve or check valve in damage. 3. Cylinder or Fittings leaks 	<p>Repair or replace</p> <p>Repair or replace</p> <p>Replace fitting and oil seal</p>
4	Lift rises slowly	<ol style="list-style-type: none"> 1. Oil line is jammed 2. Motor running on low voltage 3. Oil mixed with air 4. Gear Pump leaks 5. Overload lifting 	<ol style="list-style-type: none"> 1. Clean the oil line 2. Check Electrical System 3. Fill tank and bleeding air 4. Replace Pump 5. Check load
5	Lift cannot lower	<ol style="list-style-type: none"> 1. Safety device are not in activated 2. Release Valve in damage 3. Oil system is jammed 	<ol style="list-style-type: none"> 1. Release the safety device 2. Repair or replace 3. Clean the oil system

IX. CAR LIFT SAFETY TIPS

Put this safety tips in a place where you can always alert the operator. Please reference to the lift manufacturer's manual for specific information about the lift.

1. Check the lift daily. If the machine breaks down or has damaged parts, do not operate, and use original equipment parts to repair.
2. **Do not** overload . The rated weight of the manufacturer design is indicated on the label of the lift.
3. Position control of the vehicle and operation of the lift can only be done by a trained and authorized person.
4. **Do not** lift a car with occupants inside. Keep the customers or bystanders away from the lift.
5. Keep the area around the lift free of obstacles, lubricating oil, grease, garbage and other debris for a long time.
6. Carefully drive the vehicle onto the lift and lifting up to the required height for operation.
Noted: lift it high enough if you are working underneath, and make sure the safety devices are locked.
7. **Noted:** removing(install) parts from(to) a vehicle would cause a sudden shift of gravity which may result in instability of the vehicle. Please refer to the vehicle manufacturer's service manual as a recommended procedure if you need remove/install parts from(to) the vehicle
8. Before lowering the lift , make sure all obstacles underneath, include tool tray, tool rack etc., are all removed.

X. Lift disposal.

When the car lift cannot meet the requirements for normal use and needs to be disposed, it should follow local laws and regulations.



Address:

SC Division: 1931 Joe Rogers Jr Blvd, Manning, SC 29102, USA

TX Division: 4310 Adler Dr., Suite #200, Dallas, TX 75211, USA

<http://www.amgohyd.com>

Manual No.: **72267611**
Revision Date: **2024/07**